

**STRAIGHT SQUARE FLANGE JACK
CLAMP TYPE - CABLE .141**

R161.277.000
SERIES N

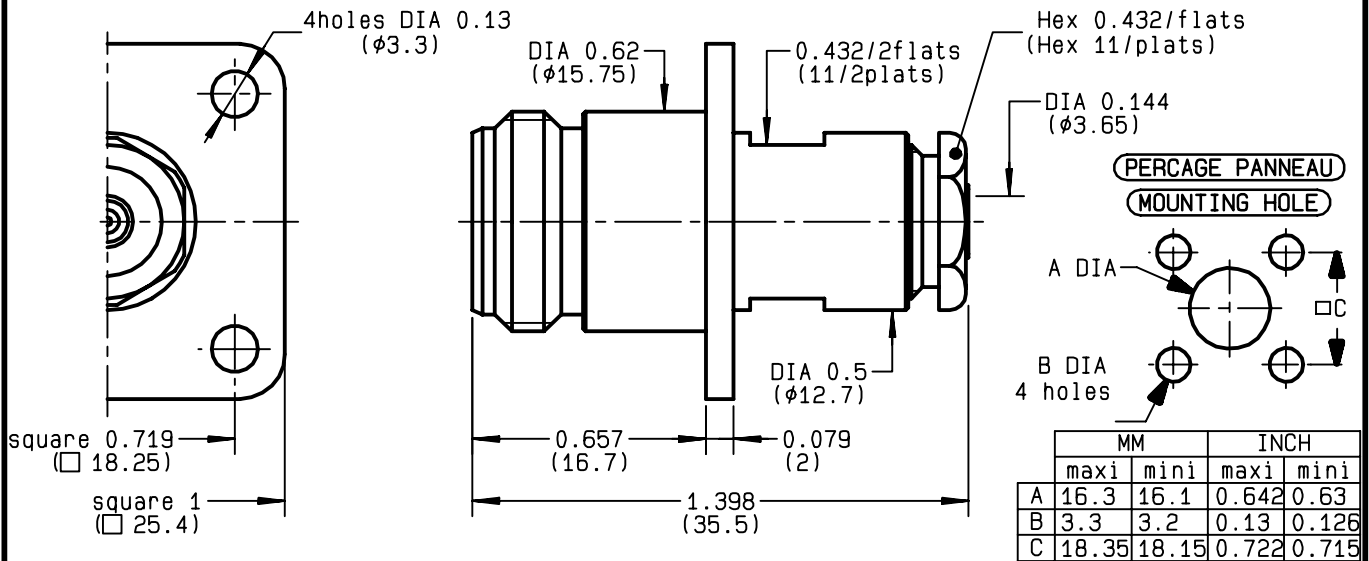

NOMINAL IMPEDANCE	50	Ω
FREQUENCY RANGE	0-11	GHz
TEMPERATURE RATING	-55/+105	$^{\circ}\text{C}$
V.S.W.R	1.15 +	x F(GHz)Maxi
RF INSERTION LOSS	0.048	\sqrt{F} (GHz) dB Maxi
VOLTAGE RATING	335	Veff Maxi
DIELECTRIC WITHSTANDING VOLTAGE	1000	Veff Mini
INSULATION RESISTANCE	5000	M Ω Mini
HERMETIC SEAL	NA	Atm.cm ³ /s
LEAKAGE (pressurized only)	NA	
MECHANICAL DURABILITY	500	Cycles
WEIGHT	37.5	gr
SPECIFICATION		

CABLES : **BELN 1673A**
HC80000-3
KS 2
RG 402
SUCOFORM 141

OTHERS CHARACTERISTICS

CABLE RETENTION	500	N Mini
CENTER CONTACT RETENTION		
Axial force - mating end	NA	N Mini
Axial force - opposite end	NA	N Mini
Torque	NA	cm.N Mini
RECOMMENDED TORQUES		
Mating	NA	cm.N
Panel nut	NA	cm.N
Clamp nut	450	cm.N

CONNECTOR PARTS	MATERIALS	FINISH	(all values are given in micrometers)
BODY	BRASS	BBR 2	
OUTER CONTACT	BRASS	BBR 2	
CENTER CONTACT	BERYLLIUM COPPER	GOLD 0.5 OVER NICKEL 2	
INSULATOR	PTFE	-	
GASKET	-	-	
OTHERS PIECES	BRASS	BBR 2	

BONMINI

ISSUE	CREATION DATE	FILE PART-NUMBER
9818T00	15/10/1992	EPC 96-07



RADIALL

The information given here is subject to change without notice.
Design changes may be in order to improve the product .

Connect to the future



R161.277.000

ISSUE **9818T00** SERIES **N**

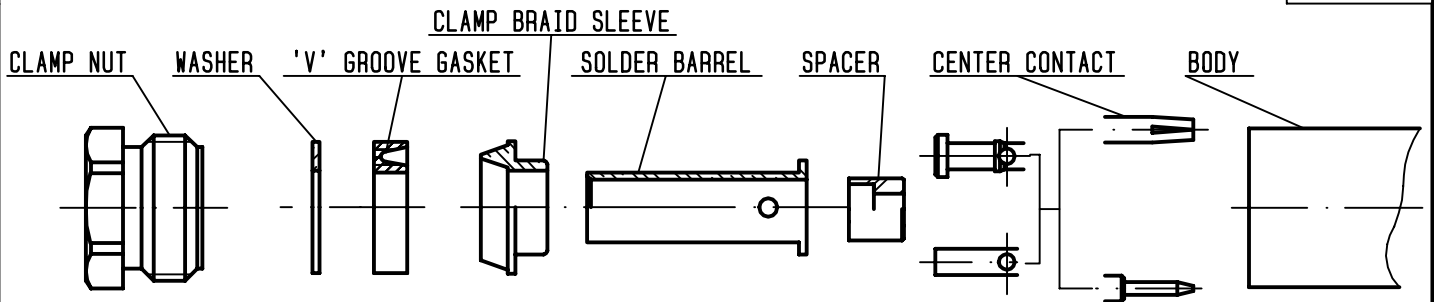

①

To take the tool kit : R 282 125 010 .
Strip the dielectric of the cable .
Stripping tool cable : R 282 053 .
Trim cable centre conductor .
Trimmer : R 282 066 010.
Clean the cable .

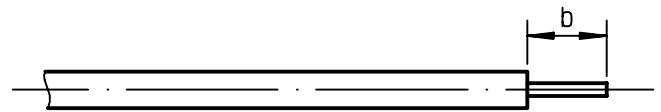

Stripping	a	b	c	d	e
inch	0	0.177 0	0	0	0
mm		4.5			

②

Slide the clamp nut , the washer , the 'V'groove gasket , the clamp braid sleeve and the solder barrel onto the cable .
Position solder barrel flush against solder barrel gauge and solder to the cable or align with outer the conductor (b) .
Solder barrel gauge : R 282 744 320 .

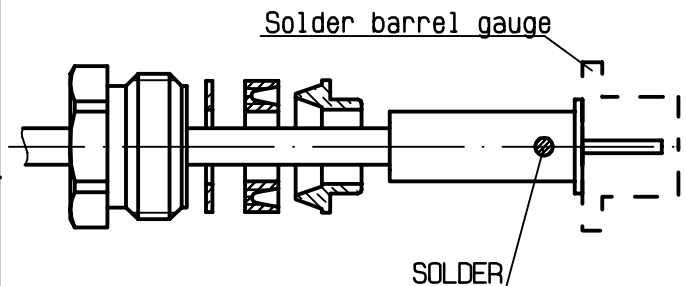

③

Once cooled , remove the solder barrel gauge.
Cut the dielectric flush to clamp braid sleeve.
Slide the insulator onto the cable inner conductor .
Slide the centre contact onto the cable inner conductor against insulator .
Fit the cable assembly onto the soldering jig R 282 740 030 and the positioner R 282 744 260 .
Tighten cable and solder the centre contact .

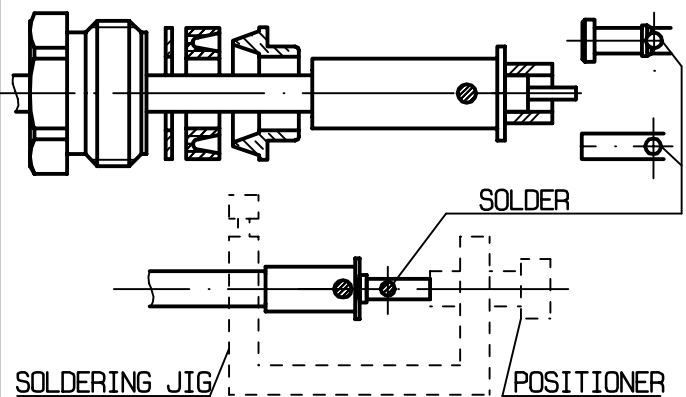

④

Screw sub-assembly into the connector body .
(recommended coupling torque 22.12 in.lb)
-
-

