

Features

- Single-Supply Operation (+2V to +6V)
- Rail-to-Rail Analog Signal Dynamic Range
- Low On-Resistance (8-ohm typ with 5V supply)
Minimizes Distortion and Error Voltages
- On-Resistance Matching Channels, 0.8-ohm typ
- On-Resistance Flatness, 3-ohm typ
- Low Charge Injection Reduces Glitch Errors. Q = 4pC typ
- Replaces Mechanical Relays
- High Speed. $t_{ON} = 10\text{ns}$ typ
- Low Off-Isolation: -72dB@1MHz
- Wide -3dB Bandwidth: 170 MHz
- High-Current Channel Capability: >100mA
- TTL/CMOS Logic Compatible
- Low Power Consumption (0.5μW typ)
- Pin-compatible with DG41X, MAX31X

Applications

- Audio, Video Switching and Routing
- Battery-Powered Communication Systems
- Computer Peripherals
- Telecommunications
- Portable Instrumentation

Description

The PI5A317A/381A/319A are analog switches designed for single-supply operation. These high-precision device is ideal for low-distortion audio, video, signal switching and routing.

The PI5A317A is a single-pole single-throw (SPST), normally closed (NC) switch. The PI5A318A has the same pinout but is a single-pole, single-throw (SPST, normally open (NO) function. The PI5A319A is a single-pole, double-throw (SPDT) switch

Each switch conducts current equally well in either direction when on. When off, they block voltages up to V_{CC} .

The PI5A317A/381A/319A are fully specified with +5V and +3.3V supplies. With +5V, they guarantee <18-ohm On-Resistance. On-Resistance matching between channels is within 2-ohm. On-Resistance flatness is less than 5-ohm over the specified range. This switch family also guarantees fast switching speeds ($t_{ON} < 20\text{ns}$).

These products are available in a 8-pin narrow body SOIC package for operation over the industrial (-40°C to +85°C) temperature range.

Functional Diagram, Pin Configuration and Truth Table

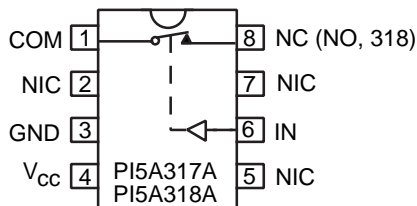

IN	PI5A317A	PI5A318A
0	ON	OFF
1	OFF	ON

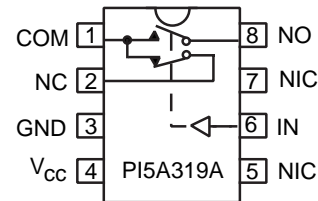

IN	SW1	SW2
0	ON	OFF
1	OFF	ON

Switches shown for Logic "0" input
 NC = Normally Closed, NO = Normally Open, NIC = Not Internally Connected

For free samples and the latest data sheet visit: www.pericom.com, or phone 1 800-435-2336

Maximum Ratings

(Above which the useful life may be impaired. For user guidelines, not tested.)

Storage Temperature	-65°C to +150°C
Ambient Temperature with Power Applied	-40°C to +85°C
Supply Voltage to Ground Potential	-0.5V to +7.0V
DC Input Voltage	-0.5V to $V_{CC}+0.5V$
DC Output Current	120mA
Power Dissipation	0.5W

Note: Stresses greater than those listed under MAXIMUM RATINGS may cause permanent damage to the device. This is a stress rating only and functional operation of the device at these or any other conditions above those indicated in the operational sections of this specification is not implied. Exposure to absolute maximum rating conditions for extended periods may affect reliability.

Single 5.0V Supply

DC Electrical Characteristics (Over the Operating Range, $T_A = -40^\circ\text{C}$ to $+85^\circ\text{C}$, $V_{CC} = 5V \pm 10\%$, $GND = 0V$)

Parameters	Description	Test Conditions ⁽¹⁾	Min.	Typ ⁽²⁾	Max.	Units
V_{ANALOG}	Analog Signal Range ⁽²⁾		0	—	5	V
R_{ON}	ON-Resistance	INC or NO = 10 mA to 30 mA	—	8	18	Ω
ΔR_{ON}	Match Between Channels	(319A)	—	0.8	2	Ω
$R_{FLAT(ON)}$	R_{ON} Flatness ⁽⁴⁾	$I_{ON} = 1\text{ mA}$, V_{NO} , $V_{NC} = 0V$ to V_{CC}	—	3	5	Ω
$I_{NO(OFF)}$ $I_{INC(ON)}$	Off Leakage Current	V_{NO} , $V_{NC} = 4.5V$	-80	—	80	nA
$I_{COM(ON)}$	On Leakage Current	V_{NO} , $V_{NC} = 4.5V$	-30	—	30	nA
I_O	Output Current	V_{NO} , V_{NC} or $V_{COM} = 0V$ to V_{CC}	100	—	—	mA
V_{IH}	Input HIGH Voltage	Guaranteed Logic HIGH Level	2.0	—	—	V
V_{IL}	Input LOW Voltage	Guaranteed Logic LOW Level	-0.5	—	0.8	V
I_{IH}	Input HIGH Current	$V_{CC} = \text{Max.}$, $V_{IN} = V_{CC}$	—	—	± 1	μA
I_{IL}	Input LOW Current	$V_{CC} = \text{Max.}$, $V_{IN} = GND$	—	—	± 1	μA
I_{CC}	Quiescent Supply Current	$V_{CC} = 5.5V$, $V_{in} = 0V$ or V_{CC}	—	—	1	μA

Dynamic Electrical Characteristics (Over the Operating Range, $T_A = -40^\circ\text{C}$ to $+85^\circ\text{C}$, $V_{CC} = 5V \pm 10\%$, $GND = 0V$)

Parameters	Description	Test Conditions(1)	Min.	Typ ⁽²⁾	Max.	Units
t_{ON}	Turn-on Time	$V_{COM} = 3.0V$, see Figure 1	—	10	20	ns
t_{OFF}	Turn-off Time	$V_{COM} = 3.0V$, see Figure 1	—	4	10	
Q	Charge Injection ⁽²⁾	$C_L = 1.0\text{ nF}$, $V_{GEN} = 0V$, see Figure 4	—	3	5	pC
$C_{(OFF)}$	NC or NO Capacitance	$f = 1\text{ kHz}$	—	13	—	pF
$C_{COM(ON/OFF)}$	COM On Capacitance	$f = 1\text{ kHz}$ (319A)	—	45	—	
$C_{COM(OFF)}$	COM Off Capacitance	$f = 1\text{ kHz}$ (317A, 318A)	—	13	—	
OIRR	Off Isolation	$R_L = 100\Omega$, $f = 1\text{ MHz}$, see Figure 2	—	-72	—	dB
BW	Bandwidth -3dB	$R_L = 100\Omega$ (319), see Figure 3 $R_L = 100\Omega$ (317, 318), see Figure 3	—	106 200	—	MHz
D	Distortion R_{FLAT}/R_L	$R_L = 100\Omega$	—	4	—	%

Notes:

- For Max or Min. conditions, use appropriate value specified under Electrical Characteristics for applicable device type.
- Guaranteed by design.

Single 3.3V Supply
DC Electrical Characteristics (Over the Operating Range, $T_A = -40^\circ\text{C}$ to $+85^\circ\text{C}$, $V_{CC} = 3.3\text{V} \pm 10\%$, $\text{GND} = 0\text{V}$)

Parameters	Description	Test Conditions ⁽¹⁾	Min.	Typ ⁽²⁾	Max.	Units
V_{ANALOG}	Analog Signal Range		0	—	V_{CC}	V
R_{ON}	ON-Resistance	$I_{\text{ON}} = 10\text{mA}$ to 30mA	—	18	28	Ω
$\Delta R_{\text{ON}}^{(3)}$	Match Between Channels		—	1	3	
$R_{\text{FLAT(ON)}}$	R_{ON} Flatness	$I_{\text{ON}} = 1\text{mA}$, V_{NO} , $V_{\text{NC}} = 0\text{V}$ to V_{CC}	—	8.7	12.5	
$I_{\text{NO(OFF)}}$ $I_{\text{NC(ON)}}$	Off Leakage Current	V_{NO} , $V_{\text{NC}} = 3.0\text{V}$	-80	—	80	nA
$I_{\text{COM(ON)}}$	On Leakage Current	V_{NO} , $V_{\text{NC}} = 3.0\text{V}$	-80	—	80	
I_{O}	Output Current	V_{NO} , V_{NC} or $V_{\text{COM}} = 0\text{V}$ to V_{CC}	80	—	—	mA
V_{IH}	Input HIGH Voltage	Guaranteed Logic HIGH Level	2.0	—	—	V
V_{IL}	Input LOW Voltage	Guaranteed Logic LOW Level	-0.5	—	0.8	
I_{IH}	Input HIGH Current	$V_{CC} = \text{Max.}$, $V_{\text{IN}} = V_{CC}$	—	—	± 1	μA
I_{IL}	Input LOW Current	$V_{CC} = \text{Max.}$, $V_{\text{IN}} = \text{GND}$	—	—	± 1	
I_{CC}	Quiescent Supply Current	$V_{CC} = \text{Max.}$, $V_{\text{IN}} = 0\text{V}$ or V_{CC}	—	—	1	

Dynamic Electrical Characteristics (Over the Operating Range, $T_A = -40^\circ\text{C}$ to $+85^\circ\text{C}$, $V_{CC} = 3.3\text{V} \pm 10\%$, $\text{GND} = 0\text{V}$)

Parameters	Description	Test Conditions ⁽¹⁾	Min.	Typ ⁽²⁾	Max.	Units
t_{ON}	Turn-on Time	$V_{\text{COM}} = 3.0\text{V}$, see Figure 1	—	28	40	ns
t_{OFF}	Turn-off Time	$V_{\text{COM}} = 3.0\text{V}$, see Figure 1	—	4	20	
Q	Charge Injection ⁽²⁾	$C_L = 1.0\text{nF}$, $V_{\text{GEN}} = 0\text{V}$, see Figure 4	—	3	5	pC
$C_{\text{(OFF)}}$	NC or NO Capacitance	$f = 1\text{ kHz}$	—	15	—	pF
$C_{\text{COM(ON/OFF)}}$	COM On Capacitance	$f = 1\text{ kHz}$ (319)	—	50	—	
$C_{\text{COM(OFF)}}$	COM Off Capacitance	$f = 1\text{ kHz}$ (317, 318)	—	15	—	
OIRR	Off Isolation	$R_L = 100\Omega$, $f = 1\text{ MHz}$, see Figure 2	—	72	—	dB
BW	Bandwidth -3dB	$R_L = 100\Omega$ (319), see Figure 3 $R_L = 100\Omega$ (317, 318), see Figure 3	—	90 200	—	MHz
D	Distortion R_{FLAT}/R_L	$R_L = 100\Omega$	—	4	—	%

Notes:

1. For Max. or Min. conditions, use appropriate value specified under Electrical Characteristics for applicable device type.
2. Guaranteed by design.

Test Circuits

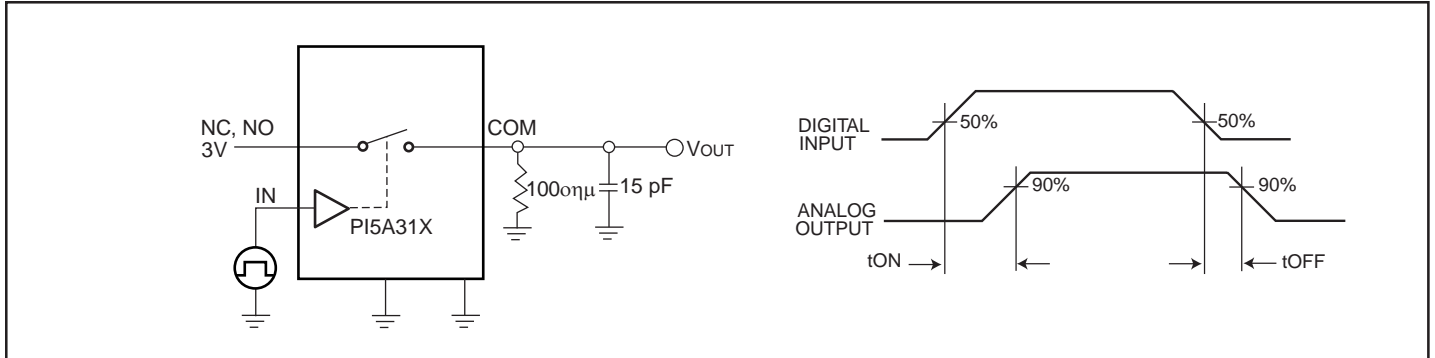

Figure 1. Switching Time

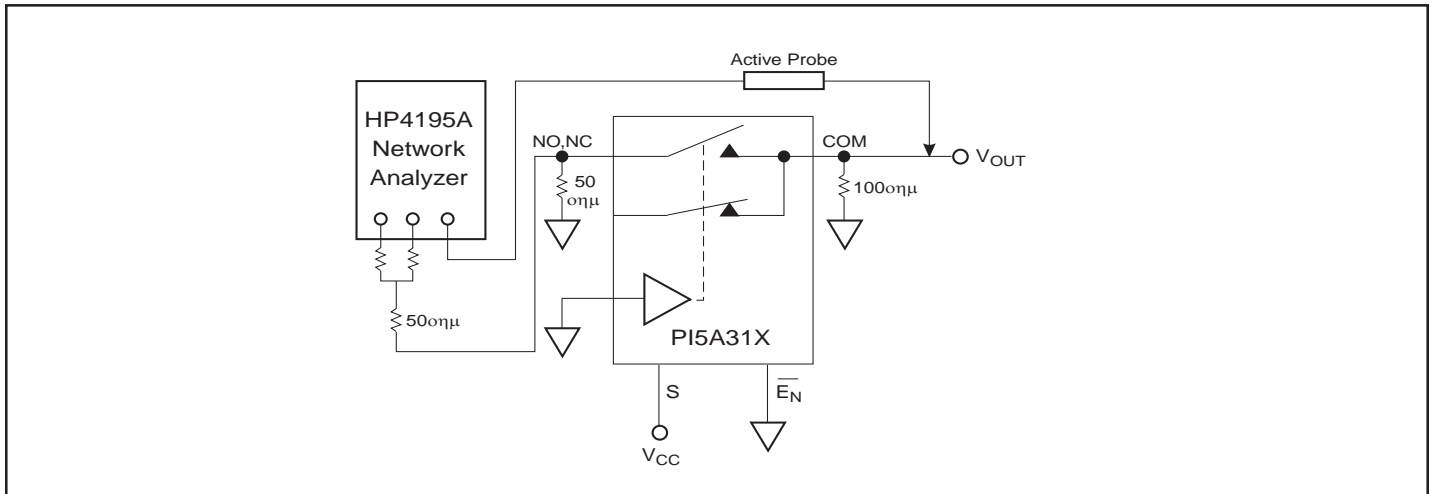

Figure 2. Off Isolation

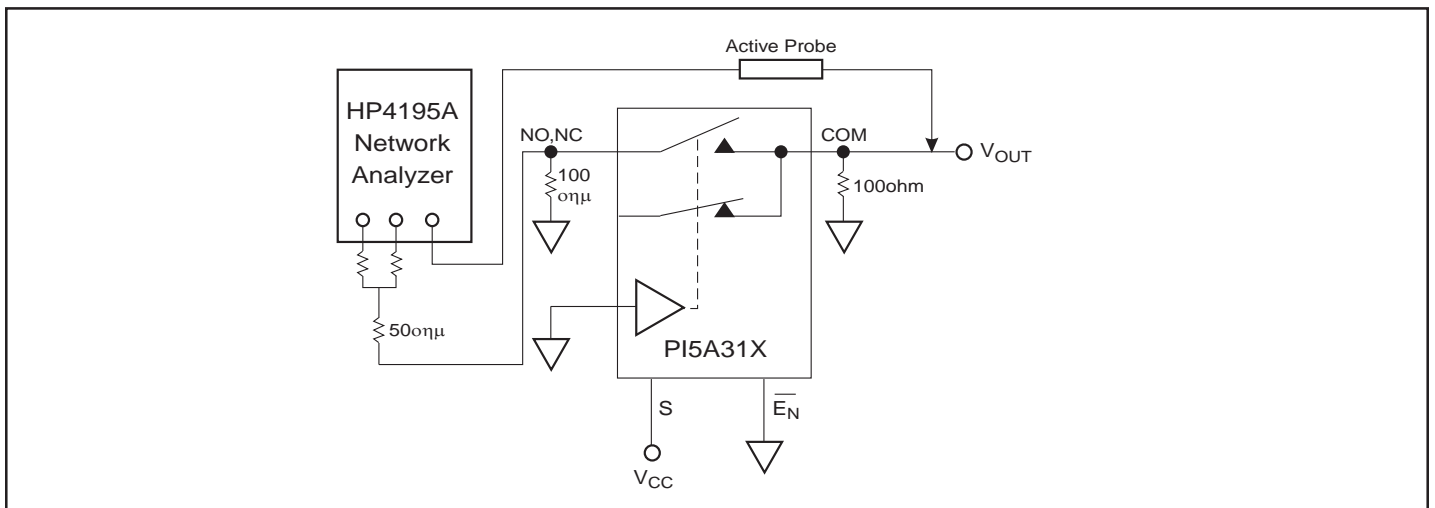

Figure 3. Bandwidth

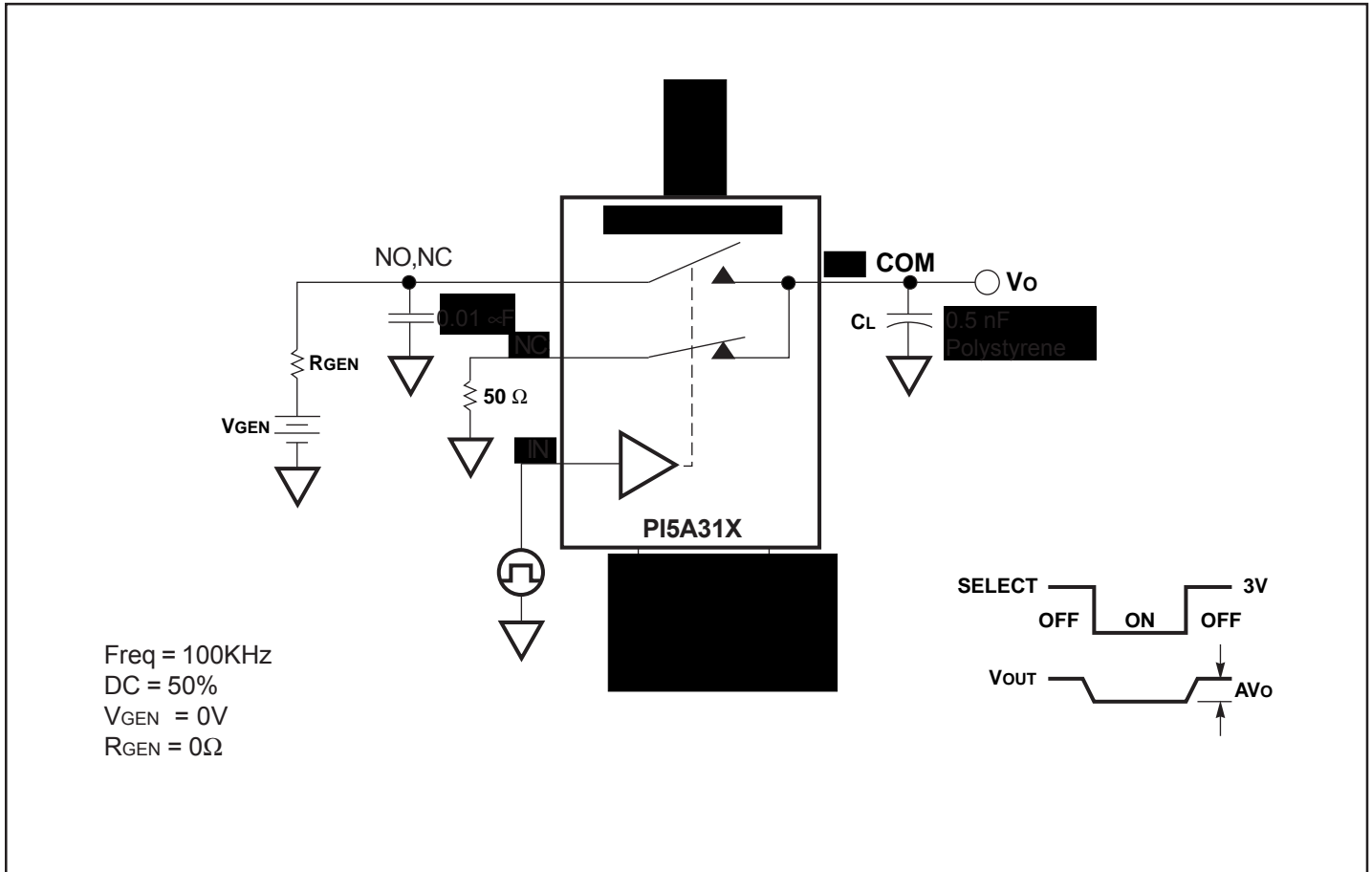

Figure 5. Charge Injection

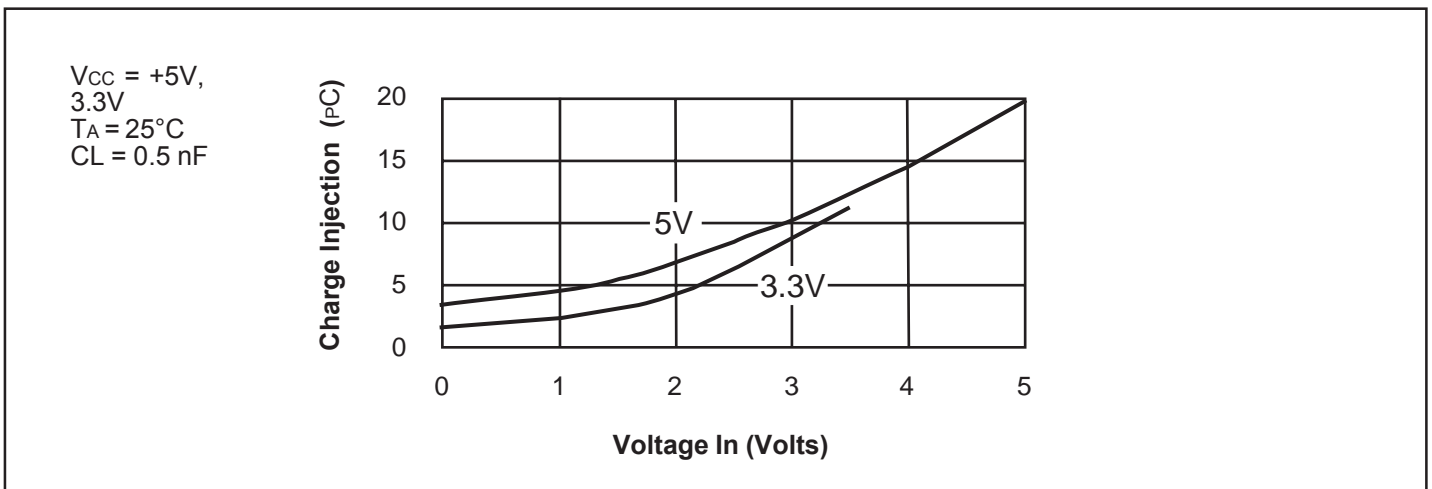

Figure 6. Charge Injection vs Analog Voltage

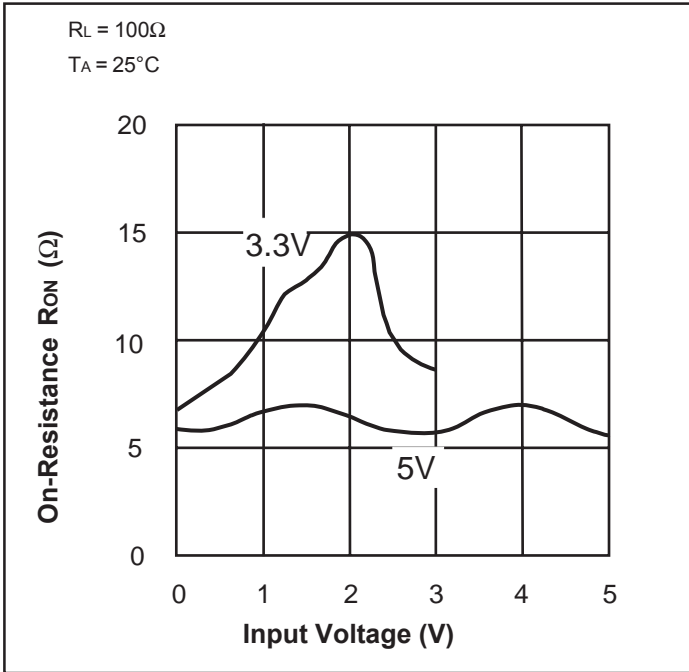

Figure 7. On-Resistance vs. Input Voltage

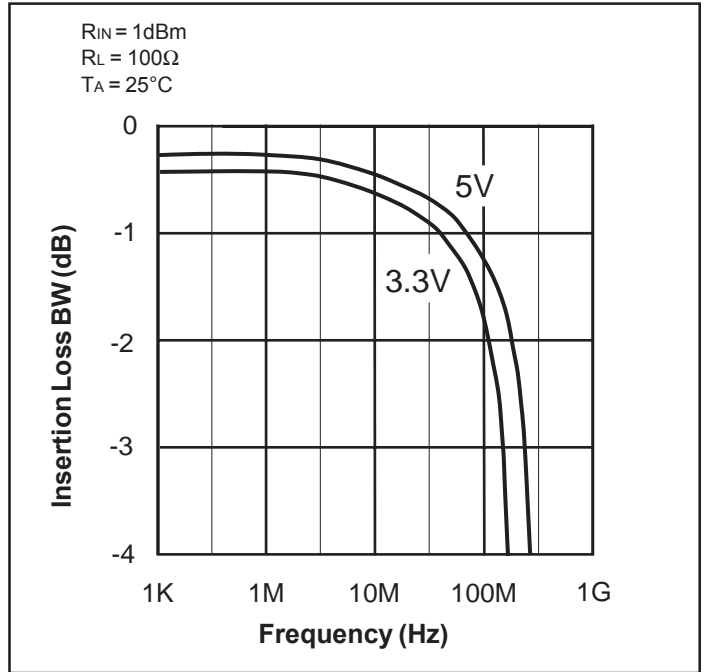

Figure 8. Insertion Loss vs. Frequency

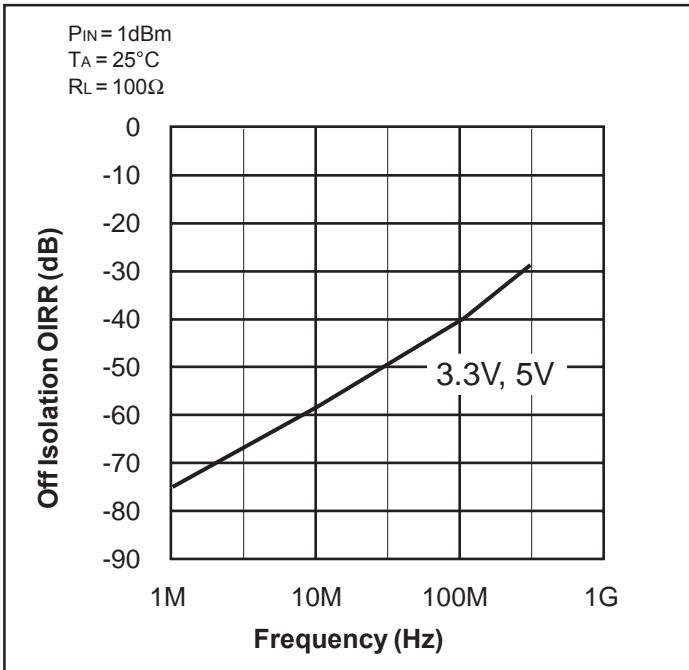

Figure 9. Off Isolation vs. Frequency

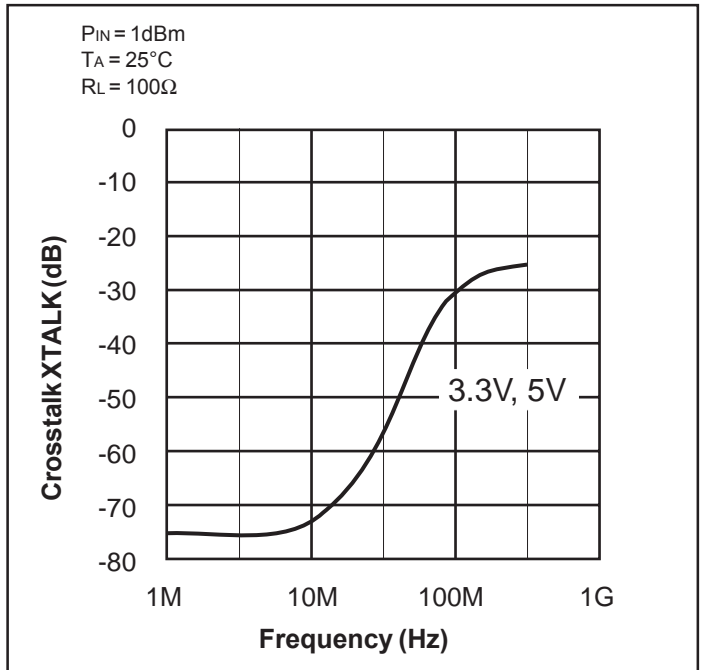
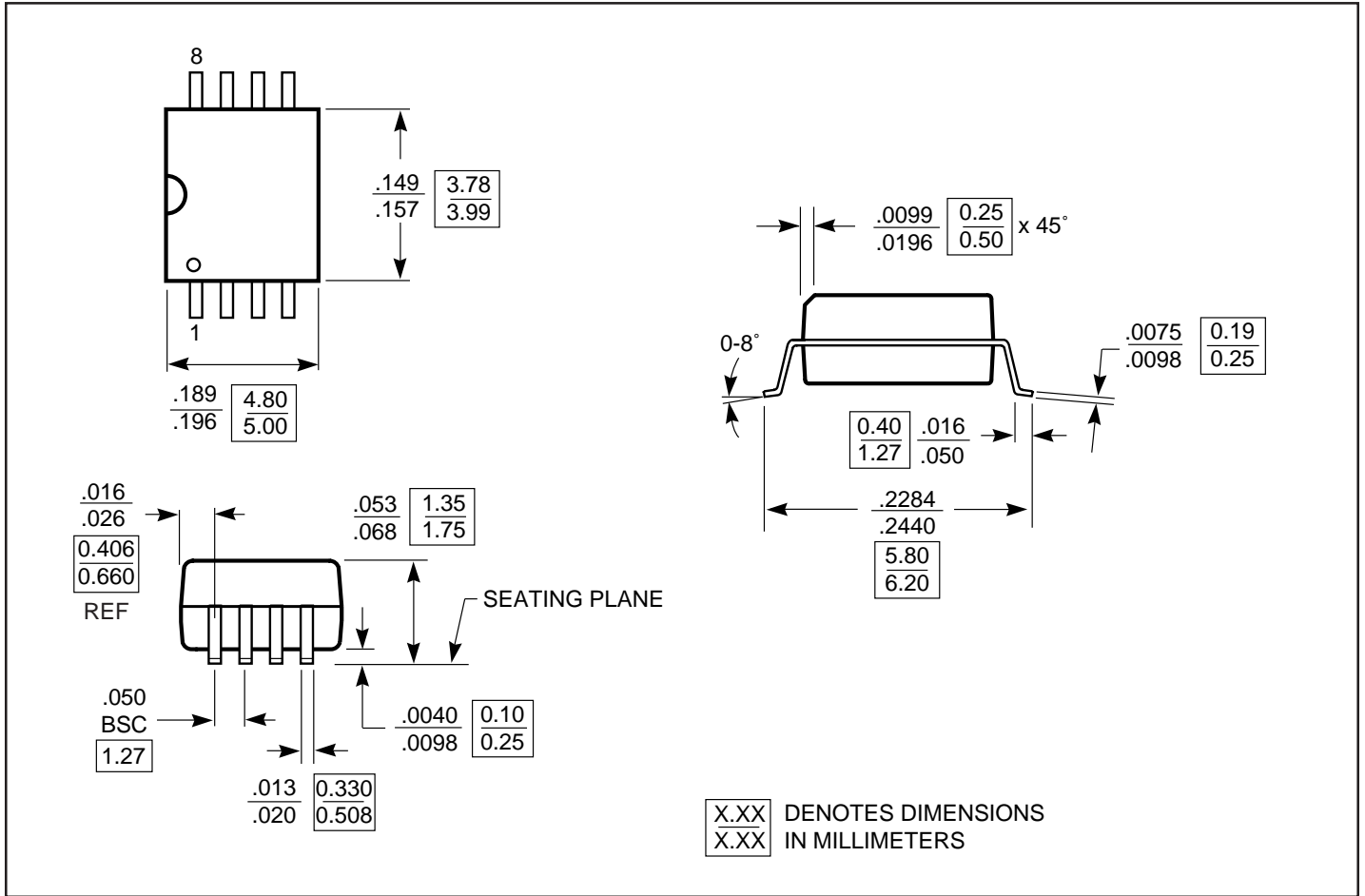

Figure 10. Crosstalk vs Frequency

Packaging Mechanical: 8-pin SOIC (package code W)



Ordering Information

Part Number	Package
PI5A317AW	8-pin Narrow Body SOIC-8
PI5A318AW	8-pin Narrow Body SOIC-8
PI5A319AW	8-pin Narrow Body SOIC-8