

STRAIGHT BULKHEAD JACK CRIMP TYPE

R123.314.000

CABLE 5/50 S

Series : QMA

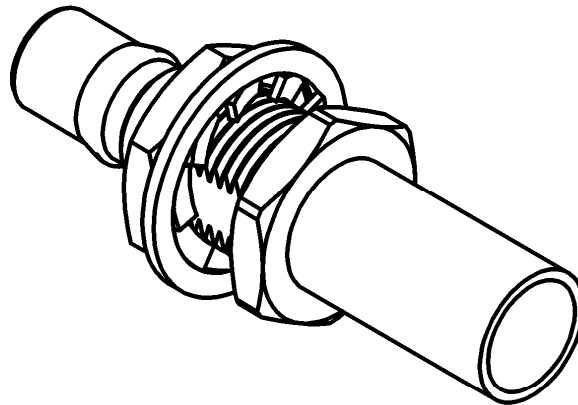
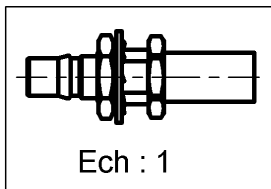
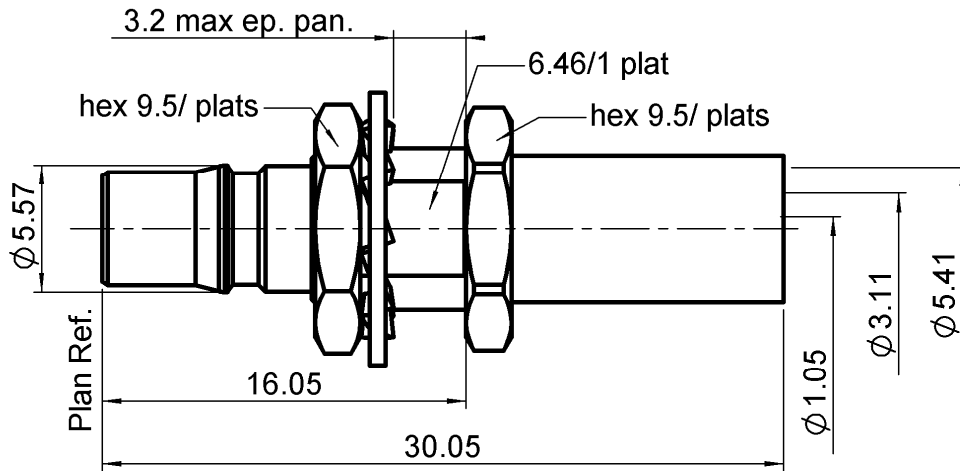

PANEL CUT OUT

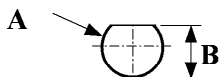

mm		
	Maxi	mini
A	7.3	7.2
B	6.65	6.5

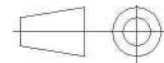

All dimensions are in mm.

COMPONENTS	MATERIALS	PLATING (µm)
BODY	BRASS	BBR 2
CENTER CONTACT	BERYLLIUM COPPER	NPGR
OUTER CONTACT	-	-
INSULATOR	PTFE	-
GASKET	-	-
OTHERS PARTS	BRASS	BBR 2
-	-	-
-	-	-

Issue : 1004 C

In the effort to improve our products, we reserve the right to make changes judged to be necessary.



STRAIGHT BULKHEAD JACK CRIMP TYPE

R123.314.000

CABLE 5/50 S

Series : QMA

PACKAGING

Standard	Unit	Other
100	'W' option	Contact us

SPECIFICATION

ELECTRICAL CHARACTERISTICS

Impedance	50	Ω
Frequency	0-6	GHz
VSWR	1.15 + 0,0200	x F(GHz) Maxi
Insertion loss	0.05	\sqrt{F} (GHz) dB Maxi
RF leakage	- (***80)	- F(GHz)) dB Maxi
Voltage rating	335	Veff Maxi
Dielectric withstanding voltage	1000	Veff mini
Insulation resistance	5000	M Ω mini

CABLE ASSEMBLY

Stripping	a	b	c	d	e	f
mm	2,80	6,50	11,0	0,00	8,20	0,00

Assembly instruction : **Crimp 02**

Recommended cable(s)

RG 141
KX 15
RG 58

Characteristics indicated on this data sheet are those that can be achieved with the highest performance cable. Intrinsic limitations of the cable may diminish the performance of the assembly

Cable retention

- pull off **110** N mini
- torque **NA** N.cm

MECHANICAL CHARACTERISTICS

Center contact retention		
Axial force – Mating end	18	N mini
Axial force – Opposite end	18	N mini
Torque	NA	N.cm mini

TOOLING

Part Number	Description	Hexagon
.	.	.
R282.223.000	CRIMPING TOOL	5.41
R282.235.011	CRIMPING DIES M22520/5-11	5.41
R282.281.000	CRIMPING TOOL	2x4 (pos. 7)
R282.293.000	CRIMPING TOOL M22520/5-01	
R282.967.016	POSITIONER FOR CRIMPING TOOL	

Recommended torque		
Mating		N.cm
Panel nut	160	N.cm
Clamp nut		N.cm
A/F clamp nut	0,0000	mm

Mating life	100	Cycles mini
Weight	5,9000	g

ENVIRONMENTAL

Operating temperature	-40/+105	$^{\circ}$ C
Hermetic seal	NA	Atm.cm3/s
Panel leakage	NA	

OTHER CHARACTERISTICS

**Intermod.: -120dBc at 1.8GHz (2x20W)
***RF Leakage interf only: $3 < F < 6$ GHz: >70dB

Issue : 1004 C

In the effort to improve our products, we reserve the right to make changes judged to be necessary.

