

MODEL ARCJ - NEMA "C" FACE-MOUNTED MOTOR ADAPTER KITS FOR CONVENIENT ADAPTATION OF SENSORS & SENSING GEARS TO GEAR CASE OR FOOT-MOUNTED NEMA "C" FACE MOTORS

DESCRIPTION

ARCJ Ring Adapters can be quickly and easily installed on foot-mounted motors with NEMA type "C" face mount end bells, or between motor and gear case flange.

The ARCJ ring, with integral junction box, is cast aluminum with precision machined mounting surfaces. Kits are supplied complete with a 60-tooth sensing gear, factory installed magnetic pickup or HESS sensor, and mounting hardware. The maximum recommended gear speed for all kits is 5,000 RPM. Two ARCJ ring sizes and five gear bores cover the range of motor frame sizes as listed in the Ordering Information.

Wiring connections to the sensor are made by removing the gasketed junction box cover. Two threaded female (1/2" NPT) conduit connections are provided for right or left conduit entry (as shown in the Dimension drawing). A threaded plug is supplied with each kit for sealing the un-used conduit entry.

The 60-tooth steel sensing gear (kit supplied) results in direct RPM indication when used with a 1 second time-base rate indicator (tachometer).

Red Lion Controls rate indicators can be configured to provide a complete speed sensing and indication system. The following two sensor options (next page) are available with the ARCJ kits in order to meet a wide variety of applications.

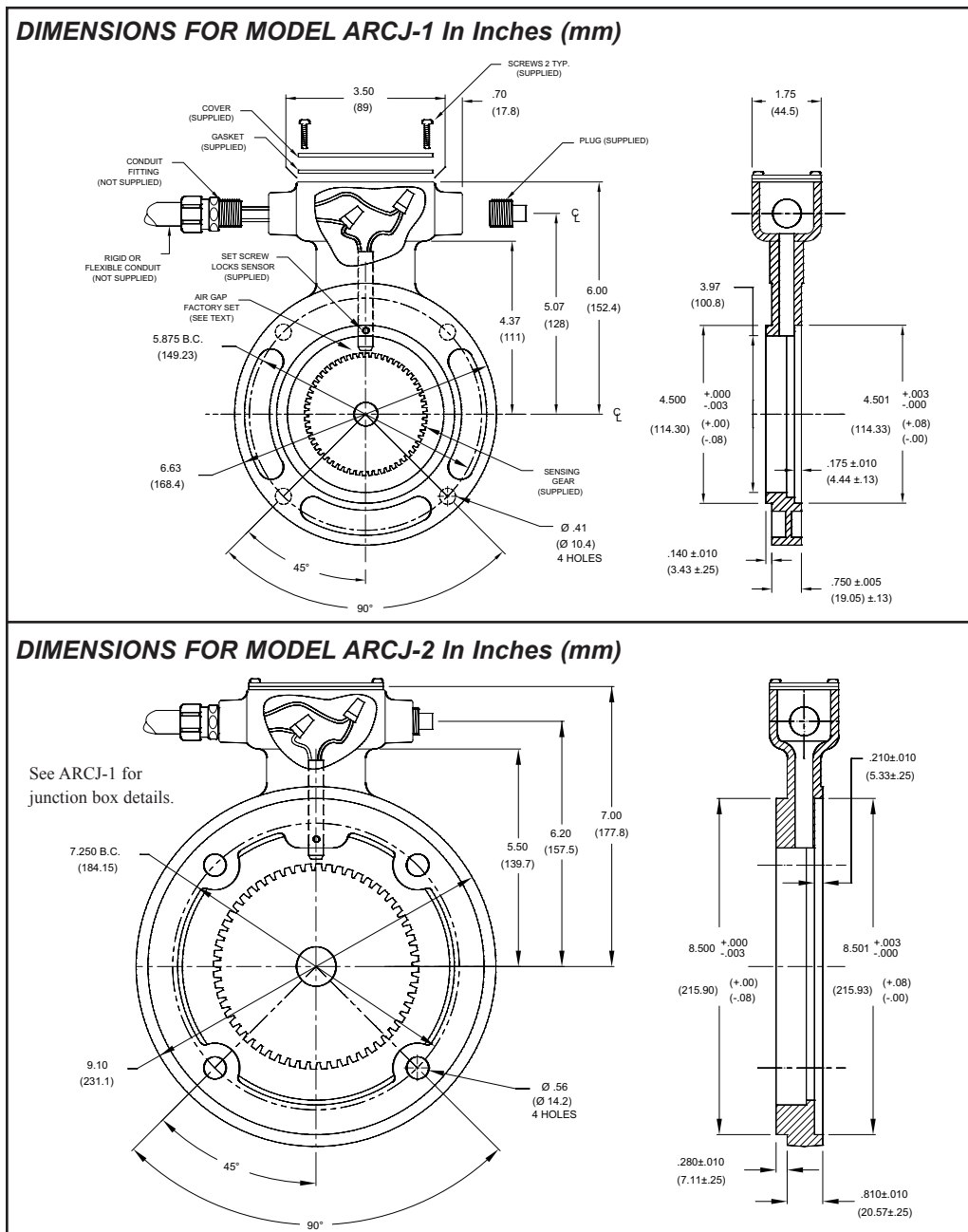

MAGNETIC PICKUP SENSOR

The ARCJ kits with this sensor option use the Red Lion Controls MP-37CA Magnetic Pickup. This sensor does not require external power.

The Magnetic Pickup is factory installed in the ring to provide a nominal sensor/gear air gap of 0.007" (0.18 mm) to 0.010" (0.25 mm). This provides adequate output from the sensor for most applications. However, if output must be maximized, the air gap can be easily user-adjusted to 0.005" (0.13 mm) minimum, once the particular gear being used is mounted on the motor shaft. (Refer to Magnetic Pickup literature for more details, enclosed in ARCJ kits.)

HALL EFFECT SPEED SENSOR (HESS)

The ARCJ kits with the HESS sensor requires an external +8 to +30 VDC power source. This sensor does **NOT** have a minimum threshold speed as does a magnetic pickup sensor. However, when the sensor is first powered up, the output state is indeterminate when the sensor is not detecting metal. The sensor face can be mounted flush into metal panels. The case is stainless steel and is supplied with 10 feet (3 M) of cable. The stranded shield wire is not connected to the sensor circuit or the case.

The sensor to gear air gap is factory set to a nominal gap of 0.015" (0.38 mm). The air gap can be adjusted by the user from 0.005" (0.13 mm) to 0.040" (1.02 mm), which allows 0.005" (0.13 mm) maximum total gear runout.

SPECIFICATIONS (HESS Sensor)

- POWER SUPPLY:** +8 to +30 VDC @ 30 mA max; Reverse Polarity Protected.
- MAXIMUM SENSING DISTANCE:** 0.040" (1 mm).
- OUTPUT:** NPN O.C. transistor; $V_{SAT} = 1 \text{ V max @ } 30 \text{ mA max. load.}$
- OPERATING TEMPERATURE RANGE:** -25°C to 70°C (-14°F to 158°F)
- CABLE LENGTH:** 10 feet (3.05 M)
- OPERATING FREQUENCY:** 0 to 10 KHz
- WIRE COLOR CODE:** 3-wire, 22 AWG with stranded drain wire and 100% foil coverage; grey PVC jacket.
- CABLE STRAIN RELIEF:** 10 lbs (4.5 Kg) for 1 minute.

Note: Do **NOT** adjust sensor air gap while target (gear) is moving.

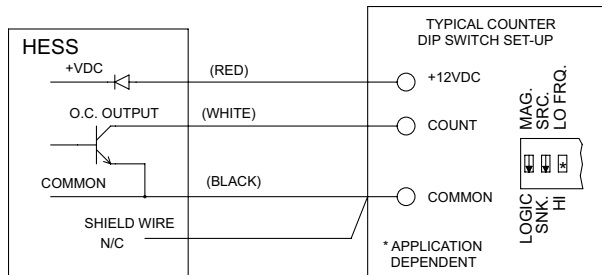

HESS DIMENSIONS In Inches (mm)

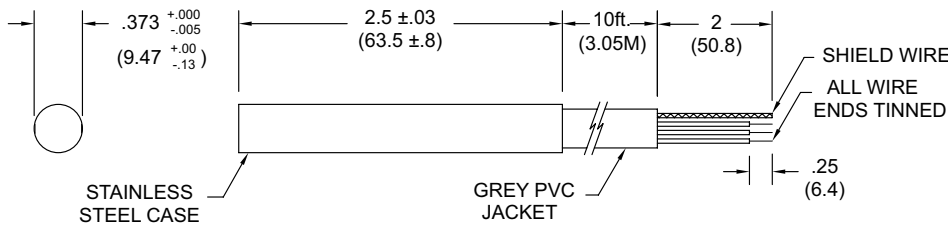

ORDERING INFORMATION

MOTOR FRAME SIZE	SHAFT DIA. (Gear Bore)	RING MODEL NO.	GEAR P/N (Ref.)	SENSOR		COMPLETE KIT PART NO.
				MAG. PICKUP	HESS	
56C	5/8"	ARCJ-1	0960625	X		ARCJ1A00
					X	ARCJ1AZ0
143TC, 145TC, 182C, 184C	7/8"	ARCJ-1	0960875	X		ARCJ1B00
					X	ARCJ1BZ0
182TC, 184TC, 213C, 215C, 254C	1 1/8"	ARCJ-2	0941125	X		ARCJ2A00
					X	ARCJ2AZ0
213TC, 215TC, 254UC, 256UC	1 3/8"	ARCJ-2	0941375	X		ARCJ2B00
					X	ARCJ2BZ0
254TC, 256TC	1 5/8"	ARCJ-2	0941625	X		ARCJ2C00
					X	ARCJ2CZ0

MODEL NO.	DESCRIPTION	PART NUMBER
HESS	Replacement Sensor for HESS Option	HESS0000
MP-37CA	Replacement Sensor for Magnetic Pickup Option	MP37CA00



Do not dispose of unit in trash - Recycle