

EVAL-M1-36-44A User Manual

iMOTION™ Modular Application Design Kit

About this document

Scope and purpose

This application note provides an overview of the evaluation board EVAL-M1-36-44A including its main features, key data, pin assignments and mechanical dimensions.

EVAL-M1-36-44A is a complete evaluation-board including a 3-phase IPM for motor drive applications. Together with EVAL-M1-101T or EVAL-M1-099M it features and demonstrates Infineon's IPM technology for motor drives.

The evaluation board EVAL-M1-36-44A for Intelligent Power Modules (IPM) was developed to support customers during their first steps designing applications with CIPOS™ Nano power modules.

Intended audience

This application note is intended for all technical specialists working with the EVAL-M1-36-44A board.

Table of Contents







About this document.....	1
Table of Contents	1
1 Safety precautions.....	2
2 Introduction.....	3
3 Main features	5
3.1 Key data	6
4 Pin Assignments	10
5 Getting Started with EVAL-M1-36-44A	12
5.1 Setting up the system.....	12
5.2 iMOTION™ development tools and software	14
5.2.1 MCEWizard setup overview.....	14
5.2.2 MCEDesigner setup overview	16
6 Schematics and Layout.....	18
6.1 DC-Link Voltage Measurement	18
6.2 Inverter section using CIPOS™ Nano IPM	19
6.3 Current Measurement and Over Current Circuit	20
6.4 Auxiliary Power supply	21
6.5 PCB Layout	22
7 Bill of Materials of EVAL-M1-36-44A.....	24
8 Reference	27
Revision History	28

Safety precautions

1 Safety precautions

In addition to the precautions listed throughout this manual, please read and understand the following statements regarding hazards associated with development systems.

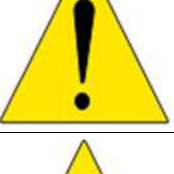
Table 1 Precautions

	Caution: <i>The ground potential of the EVAL-M1-36-44A system is biased to a negative DC bus voltage potential. When measuring voltage waveform by oscilloscope, the scope's ground needs to be isolated. Failure to do so may result in personal injury or death, and equipment damage. Darkened display LEDs are not an indication that capacitors have discharged to safe voltage levels.</i>
	Caution: <i>EVAL-M1-36-44A system contains DC bus capacitors which take time to discharge after removal of the main supply. Before working on the drive system, wait three minutes for capacitors to discharge to safe voltage levels. Failure to do so may result in personal injury or death. Darkened display LEDs are not an indication that capacitors have discharged to safe voltage levels.</i>
	Caution: <i>Only personnel familiar with the drive and associated machinery should plan or implement the installation, start-up and subsequent maintenance of the system. Failure to comply may result in personal injury and/or equipment damage.</i>
	Caution: <i>The surfaces of the drive may become hot, which may cause injury.</i>
	Caution: <i>The EVAL-M1-36-44A board contains parts and assemblies sensitive to electrostatic discharge (ESD). Electrostatic control precautions are required when installing, testing, servicing or repairing this assembly. Component damage may result if ESD control procedures are not followed. If you are not familiar with electrostatic control procedures, refer to applicable ESD protection handbooks and guidelines.</i>
	Caution: <i>An incorrectly applied or installed drive can result in component damage or reduction in product lifetime. Wiring or application errors such as undersized motor, incorrect or inadequate DC supply, or excessive ambient temperatures may result in system malfunction.</i>
	Caution: <i>Remove or connect the control board from or to the power drive. Wait three minutes after removing power from the power drive to discharge the bus capacitors. Do not attempt to service the drive until the bus capacitors have discharged to zero. Failure to do so may result in personal injury or death.</i>
	Caution: <i>The EVAL-M1-36-44A board is shipped with packing materials that need to be removed prior to installation. Failure to remove all packing materials which are unnecessary for system installation may result in overheating or abnormal operating condition.</i>

Introduction

2 Introduction

The EVAL-M1-36-44A evaluation board is a part of the iMOTION™ Modular Application Design Kit for drives (iMOTION™ MADK).

The MADK-platform is intended to use various power stages with different control boards. These boards can be easily interfaced through the 20 pin iMOTION™ MADK M1 interface connector which is 20 pin connector.

This evaluation board was designed to give comprehensible solutions of a power stage featuring CIPOST™ Nano. The board is equipped with all assembly groups for sensor less field oriented control (FOC). DC-link is provided by direct DC-input to give direct control to DC-ripple by external source. It contains in every of three output phases emitter-shunts for current sensing and a voltage divider for DC-link voltage measurement.

The EVAL-M1-36-44A evaluation board is available from Infineon. The features of this board are described in the design feature chapter of this document, whereas the remaining paragraphs provide information to enable the customers to copy, modify and qualify the design for production, according to their own specific requirements.

Environmental conditions were considered in the design of the EVAL-M1-36-44A. The design was tested as described in this document but not qualified regarding safety requirements or manufacturing and operation over the whole operating temperature range or lifetime. The boards provided by Infineon are subject to functional testing only.

Evaluation boards are not subject to the same procedures as regular products regarding Returned Material Analysis (RMA), Process Change Notification (PCN) and Product Discontinuation (PD). Evaluation boards are intended to be used under laboratory conditions by specialists only.

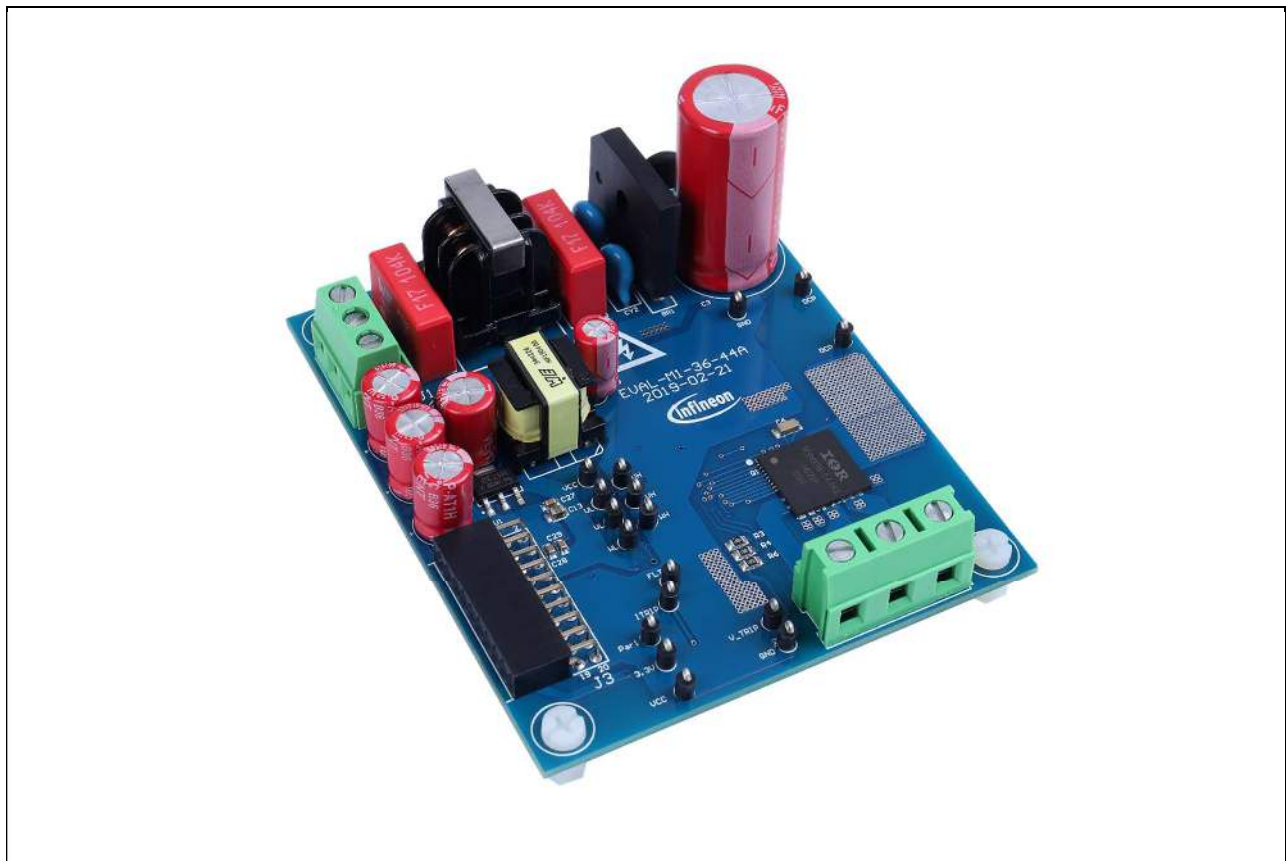

Figure 1 Evaluation-board EVAL-M1-36-44A

Introduction

Figure 1 shows the evaluation board EVAL-M1-36-44A. This document explains the features and details of CIPOS™ Nano IRSM836-044MA. This module is rated 250 V. Ratings and other details of the board are explained in the subsequent sections.

Main features

3 Main features

EVAL-M1-36-44A is an evaluation board for motor drive applications based on a 3-phase IPM. Combined with one of the available MADK control board options, it demonstrates Infineon's IPM technology for motor drives. The kit demonstrates Infineon's IPM technology for motor drives.

CIPOS™ Nano Intelligent Power Module (IRSM836-044MA) features are:

- Integrated gate drivers and bootstrap functionality
- Open-source for leg-shunt current sensing
- Protection shutdown pin
- Low RDS (on) Trench MOSFET
- Under-voltage lockout for all channels
- Matched propagation delay for all channels
- Optimized dV/dt for loss and EMI trade offs
- 3.3 V Schmitt-triggered active high input logic
- Motor power range up to ~150 W, without heat sink
- Cross-conduction prevention logic
- Isolation 1500 V RMS min
- ROHS compliant

The evaluation board characteristics are:

- Nominal input voltage 120 V_{AC}
- Default 120 W motor power out
- 3 leg shunt configuration
- 3.3 V logic compatible
- Overcurrent protection
- Fault diagnostic output
- PCB is 90x 75mm has two layers with 1oz (~35μm) copper each
- RoHS compliant

Main features

3.1 Key data

Figure 2 provides internal electrical schematics of IRSM836-044MA. For further information regarding these IPMs like static and dynamic electrical behavior, as well as thermal and mechanical characteristics please refer to the datasheet of the IRSM836-044MA.

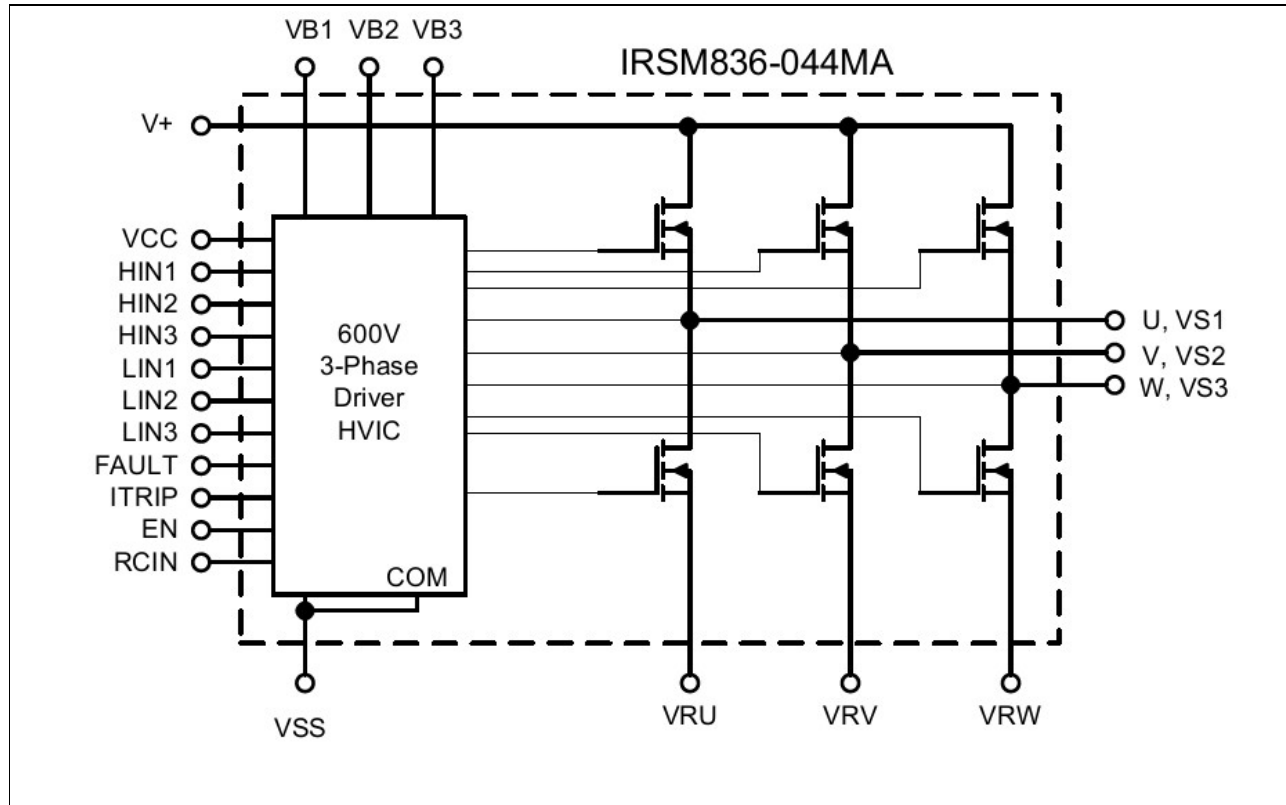

Figure 2 CIPOS™ Nano internal electrical schematic

Table 2 lists major absolute maximum ratings of the IRSM836-044MA. Absolute maximum ratings are limitations which should not be less than minimum or higher than maximum ratings. Outside these limitations for safe operation, damage of the module should be expected.

Table 2 CIPOS™ Nano Absolute Maximum Ratings of IRSM836-044MA

Symbol	Description	Min	Max	Unit
BV_{DSS}	MOSFET Blocking Voltage	---	250	V
$I_o @ T=25^{\circ}C$	DC Output Current per MOSFET	---	4	A
I_{OP}	Pulsed Output Current	---	16	A
$P_d @ TC=25^{\circ}C$	Maximum Power Dissipation per MOSFET	---	22	W
V_{iso}	Isolation Voltage (1min)	---	1500	V_{RMS}
T_J	Operating Junction Temperature	-40	150	$^{\circ}C$
T_L	Lead Temperature (Soldering, 20 seconds)	---	260	$^{\circ}C$
T_s	Storage Temperature	-40	150	$^{\circ}C$
$V_{S1,2,3}$	High Side Floating Supply Offset Voltage	$V_{B1,2,3} - 20$	$V_{B1,2,3} + 0.3$	V
$V_{B1,2,3}$	High Side Floating Supply Voltage	-0.3	250	V

Main features

Symbol	Description	Min	Max	Unit
V_{CC}	Low Side and Logic Supply voltage	-0.3	20	V
V_{IN}	Input Voltage of LIN, HIN, ITRIP, EN, RCIN, FLT	$V_{SS} - 0.3$	$V_{CC} + 0.3$	V

Table 3 depicts the recommended operating conditions of IRSM836-044MA.

Table 3 Recommended operating conditions of CIPOS™ Nano IRSM836-044MA

Symbol	Description	Min	Max	Unit
$V+$	Positive DC Bus Input Voltage	---	200	V
$V_{S1,2,3}$	High Side Floating Supply Offset Voltage	---	200	V
$V_{B1,2,3}$	High Side Floating Supply Voltage	$V_S + 10$	$V_S + 20$	V
V_{CC}	Low Side and Logic Supply Voltage	11.5	18.5	V
V_{IN}	Input Voltage of L_{IN} , H_{IN} , I_{TRIP} , EN, FLT	0	5	V
F_P	PWM Carrier Frequency	---	20	kHz

Main features

Table 4 shows the important specifications of the evaluation board EVAL-M1-36-44A.

Table 4 EVAL-M1-36-44A board specifications

Parameters	Value	Conditions
Input		
Voltage	100 - 120 V _{rms}	lower AC input, less motor power output
Input current	1 A	input 120 V _{AC} , T _a =25°C, IRSM836-044MA
Output		
Power(3phases)	120 W**	IRSM836-044MA
Current per leg	0.75 A*	IRSM836-044MA
	f _{PWM} =6 kHz, T _a =25°C, T _c =100°C, */**without heatsink	
DC Bus		
Maximum DC bus voltage	200 V	
Minimum DC bus voltage	60 V	
Current feedback		
Current sensing device RS1,RS2,RS3	0.5 Ω	The default configuration uses three shunts in the emitter paths. To implement single shunt sensing, the board should be modified: 1) RS1 and RS3 have to be removed 2) IU+,IV+,IW+ have to be connected 3) R36 has to be changed to 10 kΩ
Protections		
Output current trip level	2.5 A _{pk}	Configured by changing either shunt resistors RS1, RS2, RS3 or comparator threshold by resistor R36
On board power supply		
15V	15 V±5 %, Max 20 mA	Used for CIPOST™ gate driver power
3.3V	3.3 V±5 %, Max 50 mA	Used for interface signal with control board and alarm signals as I _{TRIP} , FLT/EN
PCB characteristics		
Material	FR4, 1.6 mm thickness, 2-layers. 35 μm Copper thickness	
Dimension	90 mm x 75 mm	
System environment		
Ambient temperature	From 0 to 70°C	95 % RH max. Non-condensing

Main features

Figure 3 and Figure 4 are indicating the functional groups of the EVAL-M1-36-44A evaluation board.

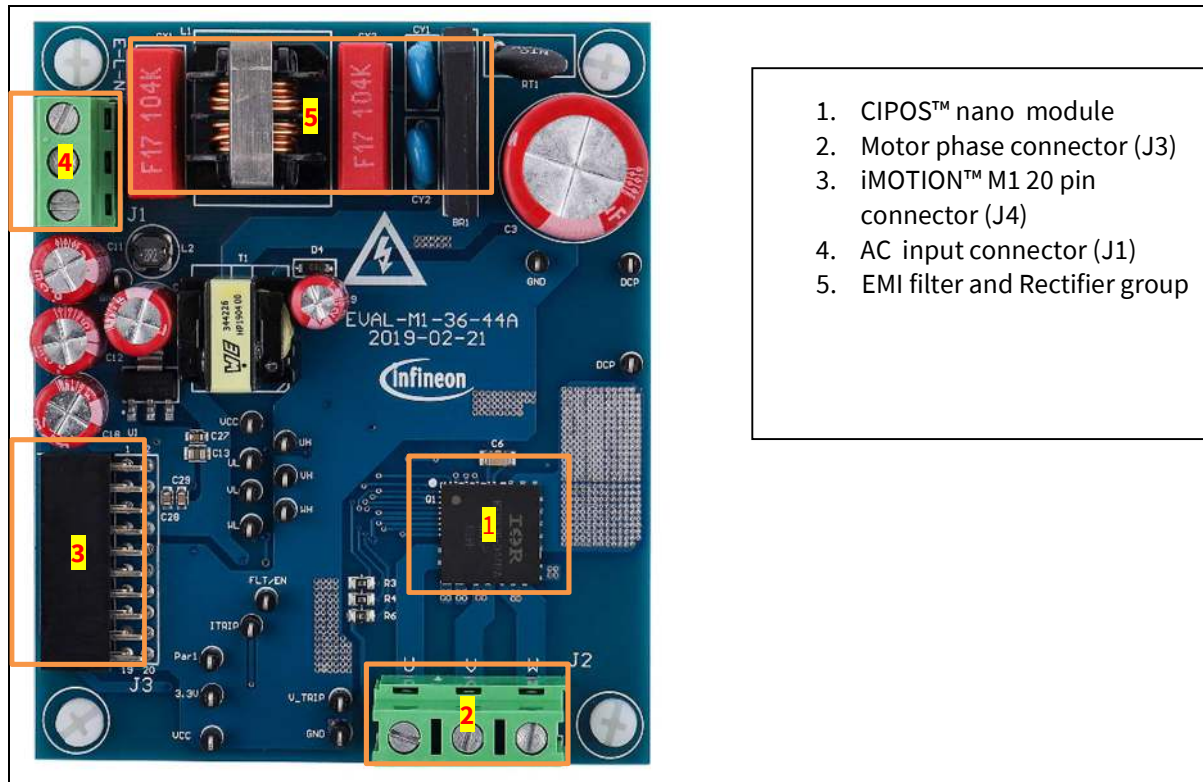

1. CIPOST™ nano module
2. Motor phase connector (J3)
3. iMOTION™ M1 20 pin connector (J4)
4. AC input connector (J1)
5. EMI filter and Rectifier group

Figure 3 Functional groups of the EVAL-M1-36-44A evaluation board's top side

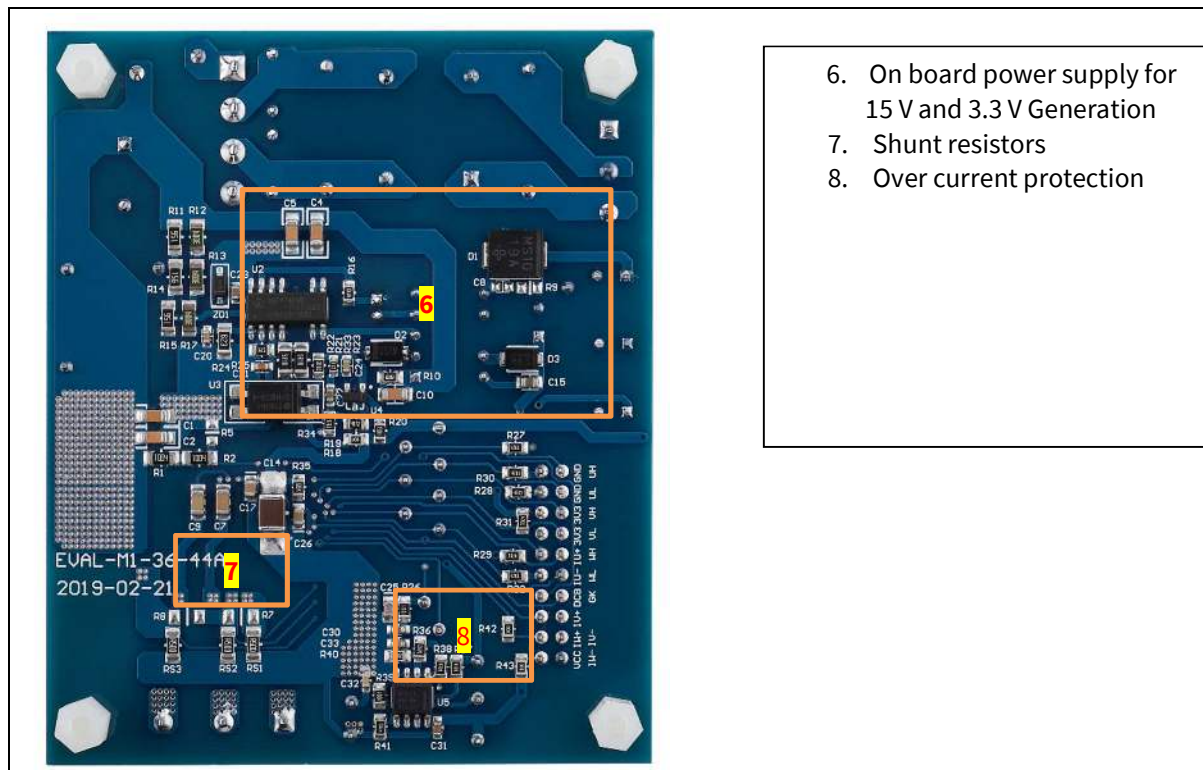

6. On board power supply for 15 V and 3.3 V Generation
7. Shunt resistors
8. Over current protection

Figure 4 Functional groups of the EVAL-M1-36-44A evaluation board's bottom side

Pin Assignments

4 Pin Assignments

General information about the connectors of the EVAL-M1-36-44A evaluation board is reported. Table 5 includes the details of the line connector J1-AC. It is possible to connect DC voltage to the AC connector. In this case a permanent DC-current will be conducted through the rectifier bridge. Maximum ratings are valid for AC as well as DC conditions. It is recommended to observe the temperature of the rectifier bridge. Due to the rectifier, DC supply's polarity at the connector is of no concern.

The evaluation board doesn't have a fuse. An external fuse is highly recommended during testing.

Table 5 J1- AC Line Connector

S. No.	Pin	Details
1	E	Earth ground
2	L	AC neutral input
3	N	AC line input

Table 6 denotes the details of the motor side connector J2.

Table 6 J2- Motor side connector

S. No.	Pin	Details
1	U	Connected to motor phase U
2	V	Connected to motor phase V
3	W	Connected to motor phase W

Pin Assignments

Table 7 registered the pin assignments of J3, iMOTION™ -M1 20 pin interface connector. This connector is the interface to the controller board.

Table 7 J3 –iMOTION™ M1 20 pin interface connector to connect EVAL-M1-36-44A to controller board

Pin	Name	Connectors
1	PWMUH	3.3 V compatible logic input for high side gate driver-Phase U
2	GND	Ground
3	PWMUL	3.3 V compatible logic input for low side gate driver-Phase U
4	GND	Ground
5	PWMVH	3.3 V compatible logic input for high side gate driver-Phase V
6	+3.3V	On board 3.3 V supply
7	PWMVL	3.3 V compatible logic input for low side gate driver-Phase V
8	+3.3V	On board 3.3 V supply
9	PWMWH	3.3 V compatible logic input for high side gate driver-Phase W
10	IU+	Shunt voltage phase U
11	PWMWL	3.3 V compatible logic input for low side gate driver-Phase W
12	IU-	Ground
13	GK	Gate kill signal – active low when over current is detected
14	DCBSENSE	DC bus positive voltage, scaled in 0-3.3 V range by a voltage divider
15	VTH	Thermistor Output
16	IV+	Shunt voltage phase V
17	IV-	Ground
18	IW+	Shunt voltage phase W
19	IW-	Ground
20	VCC	15 V power supply

5 Getting Started with EVAL-M1-36-44A

In order to run the motor system, a combination of the iMOTION™ MADK power board EVAL-M1-36-44A and the matching MADK control board (with M1 connector, EVAL-M1-101T for example in this chapter) is required. The iMOTION™ Software Tools MCEDesigner and MCEWizard are also required in order to initially setup the system, as well as to control and fine-tune the system performance to match users exact needs. This chapter provides more details on setting up the system and getting started with iMOTION™ MADK development platform.

5.1 Setting up the system

After downloading and installing the iMOTION™ PC Tools (MCEWizard and MCEDesigner), following steps need to be executed in order to run the motor. Refer to chapters 5.2.1 and 5.2.2 as well as MCEWizard and MCEDesigner documentation for more information.

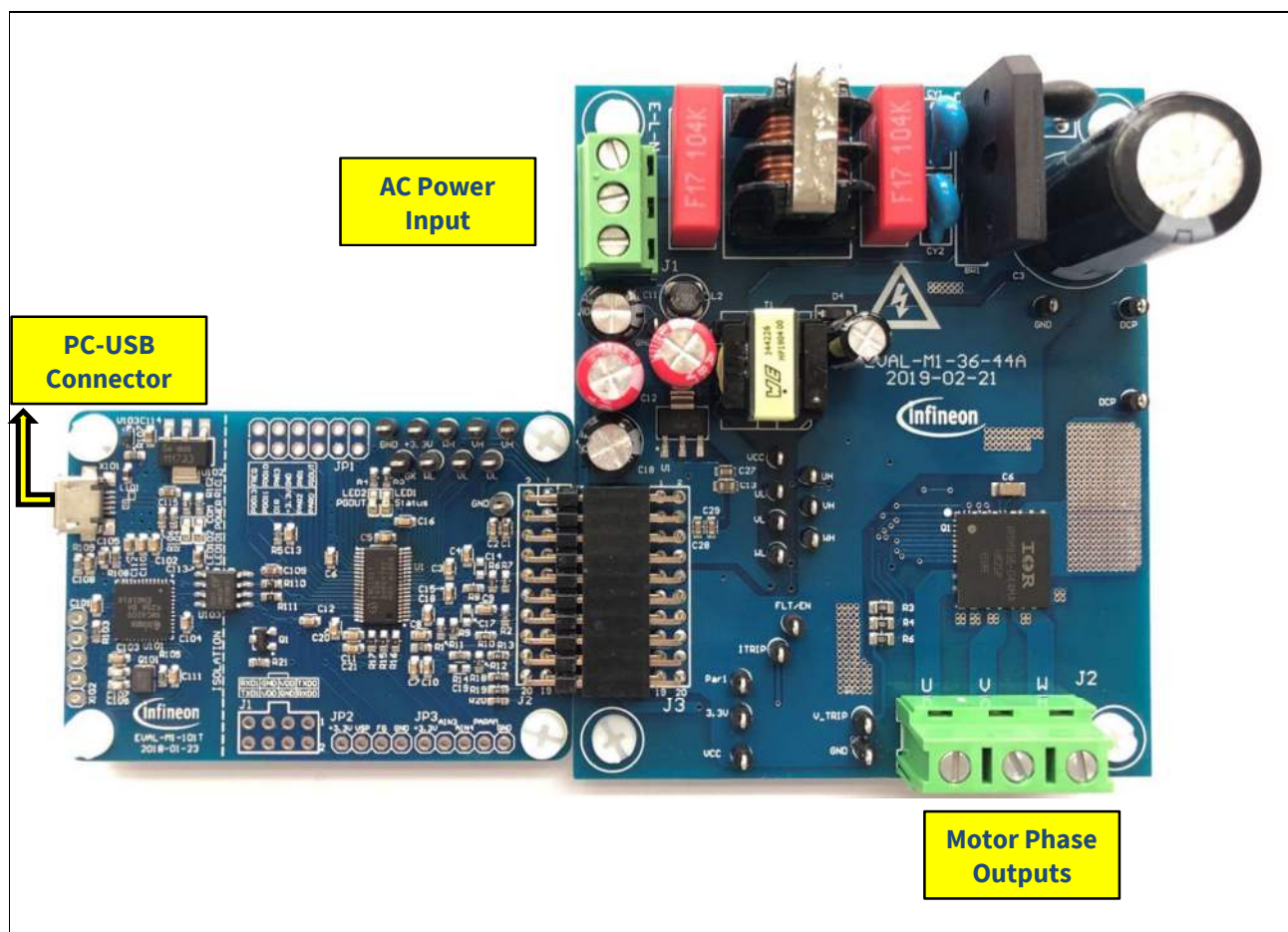

Figure 5 System connection example using EVAL-M1-101T and EVAL-M1-36-84A

1. Connect PC-USB connector on the on-board-debugger to the PC via USB cable.
2. Connect EVAL-M1-36-A's MADK M1 20-pin interface connector (J3) to control board (see Figure 5).
3. Get the latest "IMC101T-T038 MCE Software Package" available on www.infineon.com/imotion-software web page. (Infineon iMOTION™ control IC IMC101T-T038 is used for control board EVAL-M1-101T).
4. Connect motor phase outputs to the motor.
5. Use MCEWizard to enter the motor and evaluation board hardware parameters and click button "Export to Designer file (.txt)" to system drive parameters file which will be used by MCEDesigner.

Getting Started with EVAL-M1-36-44A

6. Connect AC power to power input connector (J1) and power on system.
7. Open MCEDesigner and open MCEDesigner default configuration file (.irc) for IMC101T devices (IMC101T_xx.irc) by clicking “File” menu and select “Open” in the pull down list.
8. Import system drive parameters file (generated in step 5) into MCEDesigner by clicking “File” > “Import Drive Parameters”. Select “Update All” radio button.
9. Program the MCE Firmware and system parameters into the internal Flash memory of iMOTION™ IC by clicking “Tools > Programmer” in the pull down menu, and then clicking on the “Program Firmware and Parameter” radio button. See chapter MCEDesigner setup overview section 5.2.2 for more details. If the latest version of MCE firmware is already programmed into the IMC101T-T038 IC, then programming firmware can be skipped by selecting “Program Parameters” radio button option. Finally click “Start” button to program firmware and parameter (or parameters only when programming firmware was skipped).
10. Start the motor by clicking the green traffic light button in the control bar.

5.2 iMOTION™ development tools and software

The iMOTION™ Development Tool installers for MCEDesigner and MCEWizard are available for download via Infineon iMOTION™ website (<http://www.infineon.com/imotion-software>). All supported tools and software variants are listed there. Please visit this page periodically to check for tool/software updates.

Isolated on-board debugger provides the USB to UART bridge between the PC and the target iMOTION™ device with 1kV DC galvanic isolation between the motor drive system (hot side) and the PC/debugger (cold) side. On-board debugger uses the SEGGER J-Link driver for UART communication with IMC101T-T038. J-Link driver will be installed during the MCEDesigner installation. In case the driver is not installed properly, please go to [SEGGER J-Link website](#) to download and install the latest J-Link “Software and Documentation pack for Windows”.

5.2.1 MCEWizard setup overview

After installing the MCEWizard, the shortcut for MCEWizard appears on the Windows desktop. Double click the shortcut to open the MCEWizard and configure the parameters for evaluation boards or motor. Figure 6 shows the “Welcome Page” for MCEWizard, where the MADK control board or power board can be selected through the pull-down list. Infineon keeps releasing new MADK controller and power boards. Therefore, it could happen that some of the newest power boards are not pre-configured in the MCEWizard tool and cannot be selected through the pull-down menu. In that case, the user should select any other power board (as similar as possible) and follow the MCEWizard setup steps by entering the parameter values which are specific to the chosen board. Make sure both “I have modified the circuit board” and “Enable advanced question” checkmarks are selected. Please refer to the Application Note of the corresponding power board for additional information.

After selecting the MADK control and the power board, start the MCEWizard system setup procedure by clicking the “Next” button in the right bottom corner as shown in Figure 6.

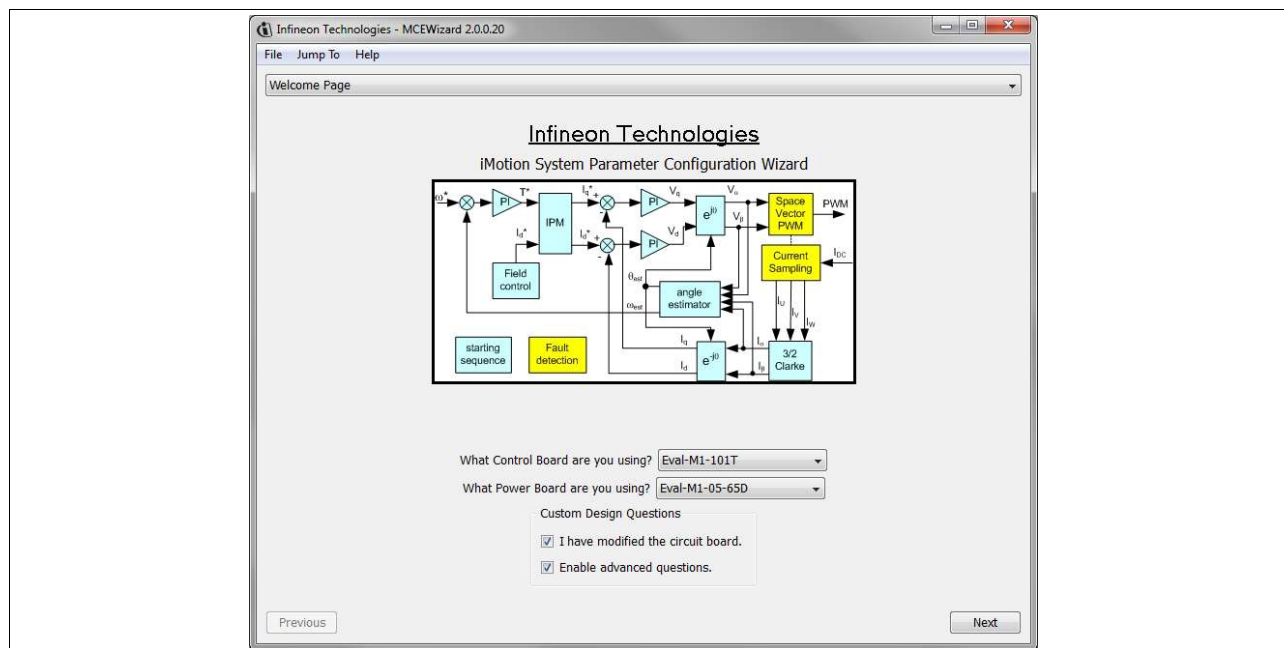

Figure 6 Welcome Page of MCEWizard

iMOTION™ MADK system enables users to easily test different combination of control and power board with their motors. User should be familiar with the system level parameters which are related to the motor used. There is a very limited number of parameters which are specific to the control board or power board hardware.

Getting Started with EVAL-M1-36-44A

Table 8 provides the MCEWizard setup overview for hardware related parameters specific to EVAL-M1-36-44A power board. Similar tables will be available in each control board’s Application Note. Combination of this table and the corresponding table of the control board provides enough information to setup the MADK-based motor drive system in shortest time.

Table 8 MCEWizard setup overview table

Page	Parameter	Value	Comment
Welcome Page	Control Board selecting	EVAL-M1-101T for example	
Welcome Page	Power Board selecting	EVAL-M1-36-44A	If no, select similar power board to modify
Options Page	Motor 1 Shunt Configuration	Leg shunt	
Question 3	Controller Supply Voltage	+3.3V	VDD is 3.3V by default
Question 19	Max DC Bus Voltage	200V	
Question 23	DC Bus Sensing High Resistor	2000 kΩ	
Question 24	DC Bus Sensing Low Resistor	Refer to the control board user manual	
Question 54	NTC Temperature Shutdown value	Refer to the control board user manual	
Question 63	GateSense Low-Side Devices	High is true	
Question 64	GateSense High-Side Devices	High is true	
Question 69	Motor 1 Current Input	Calculated in the corresponding Section in control board user manual	

After all the MCEWizard questions are answered, the “Verify & Save Page” will be shown as in Figure 7.



Figure 7 Verify and Save page for MCEWizard

Getting Started with EVAL-M1-36-44A

Click “Calculate” button and “Export to Designer File (.txt)” button to save the parameter file which will be used by the MCEDesigner in the next steps.

5.2.2 MCEDesigner setup overview

After installing MCEDesigner installer, there is a shortcut for MCEDesigner on Windows desktop. Double click the shortcut to open MCEDesigner and then open “IMC101T_xx.irc” file as shown in Figure 8.

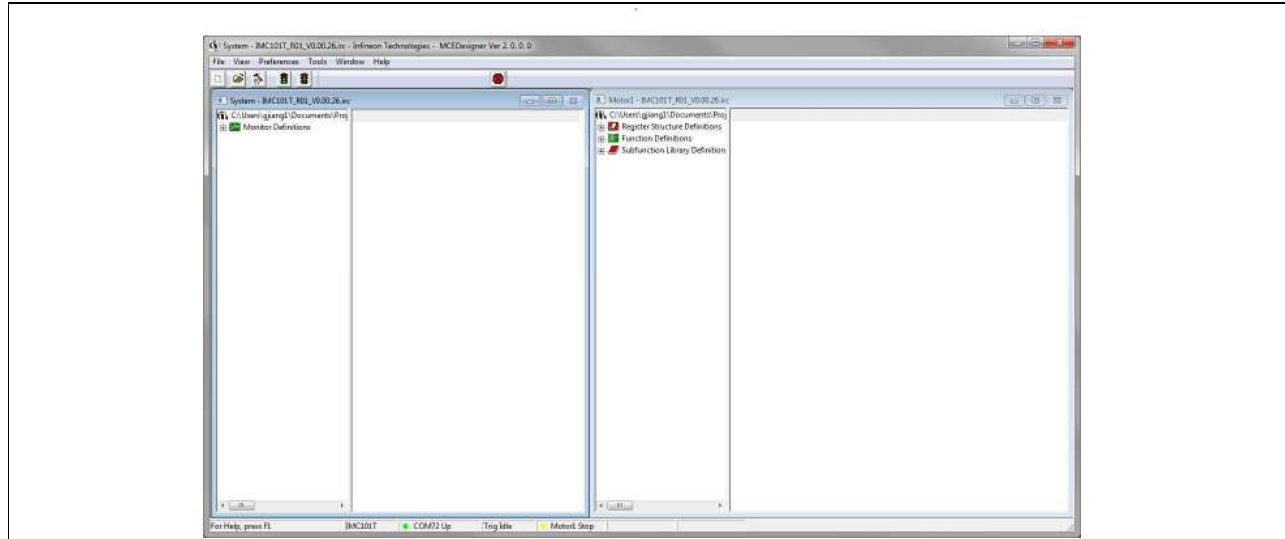

Figure 8 MCEDesigner’s Main Display for EVAL-M1-101T

To program Drive System Parameter file into IMC101T-T038, please click “Tools” menu and select “Programmer” in the pull down list. The pop-up window “Program IMC controller” will show up as in Figure 9. Click on the “Program Parameters” radio button (this is the default option), and then select the Drive System Parameter file created using MCEWizard by clicking on “Browse”. Finally, click on the “Start” button to program the parameter file into the IMC101T-T038 IC.

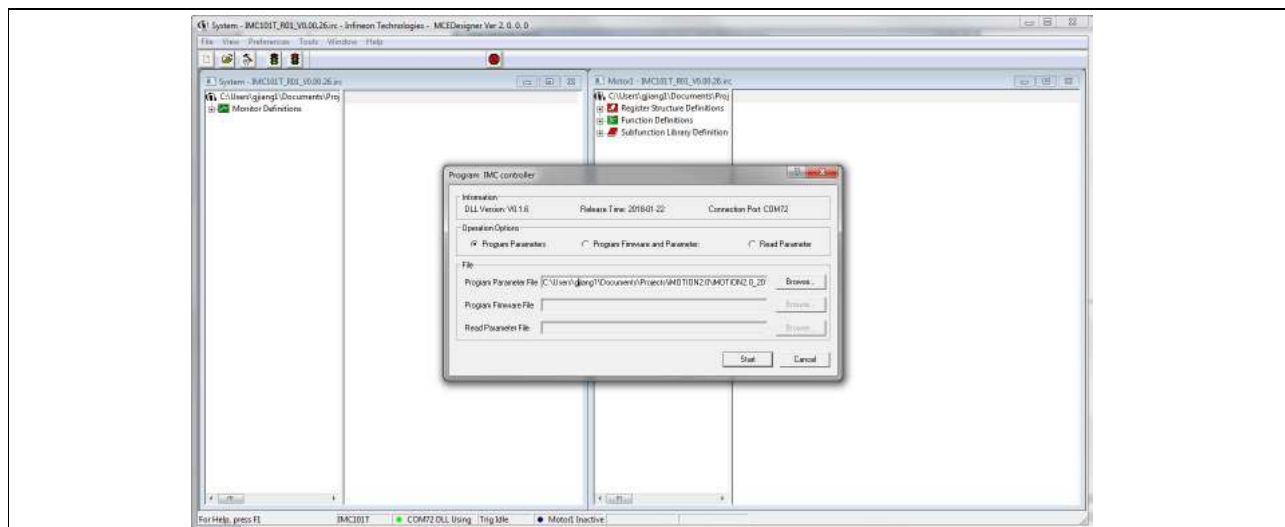

Figure 9 “Program IMC Controller” pop-up window

Getting Started with EVAL-M1-36-44A

After Drive System Parameter file has been programmed into IMC101 controller, and the motor drive system is powered, the MCEDesigner can be used to start/stop the motor, display motor current traces, change the motor speed, modify drive parameters and many other functions. Please refer to the MCEDesigner documentation for more details.

Note: On-board Debugger portion of EVAL-M1-101T is galvanically isolated from the controller portion and the attached power board. In order to program the parameters or firmware to the IMC101T-T038 controller, the 3.3V DC voltage needs to be supplied to the controller portion of the EVAL-M1-101T. This voltage can either be supplied by the power board (MADK power boards are designed to supply the 3.3V to the control board through M1 or M3 connector) or by feeding the 3.3V DC voltage to the control board through some of the available 3.3V access/test points if the power board is not attached to the EVAL-M1-101T control board.

To program new firmware and Drive System Parameter into IMC101T-T038, please click “Tools” menu and select “Programmer” in the pull down list. The pop-up window “Program IMC controller” will show up as in Figure 10. Click on the “Program Firmware and Parameter” radio button, and select the Drive System Parameter file created using MCEWizard by clicking on the “Browse” button on the row of “Program Parameter File”, and then select the firmware file by clicking on the “Browse” button on the row of “Program Firmware File”. Finally, click on the “Start” button to program the parameter file into the IMC101T-T038 IC.

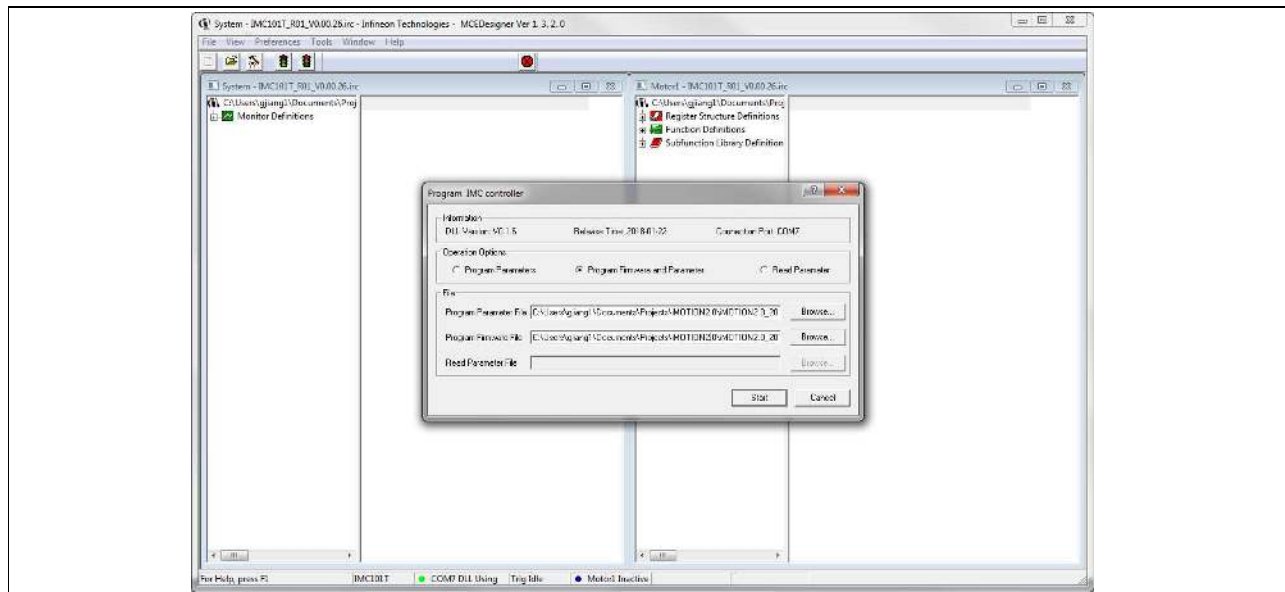

Figure 10 Program Firmware and Parameter in “Program IMC Controller” pop-up window

All the latest firmware files for different types of iMOTION™ motor control ICs are available for download via Infineon iMOTION™ website (<http://www.infineon.com/imotion-software>).

6 Schematics and Layout

To meet individual customer requirements and make the EVAL-M1-36-44A evaluation board a basis for development or modification, all essential technical data like schematics, layout and components are included in this chapter. Get in contact with our technical support team to get more detailed information and the latest Gerber-files.

6.1 DC-Link Voltage Measurement

Pin 14 of connector J4 provides access to the DC-link voltage. Three possible feedback cases are associated with this pin. Figure 11 provides the DC bus sense resistor details. By default, the resistor R5 is not mounted on EVAL-M1-36-44A. There must be a pull-down resistor mounted on the corresponding controller board.

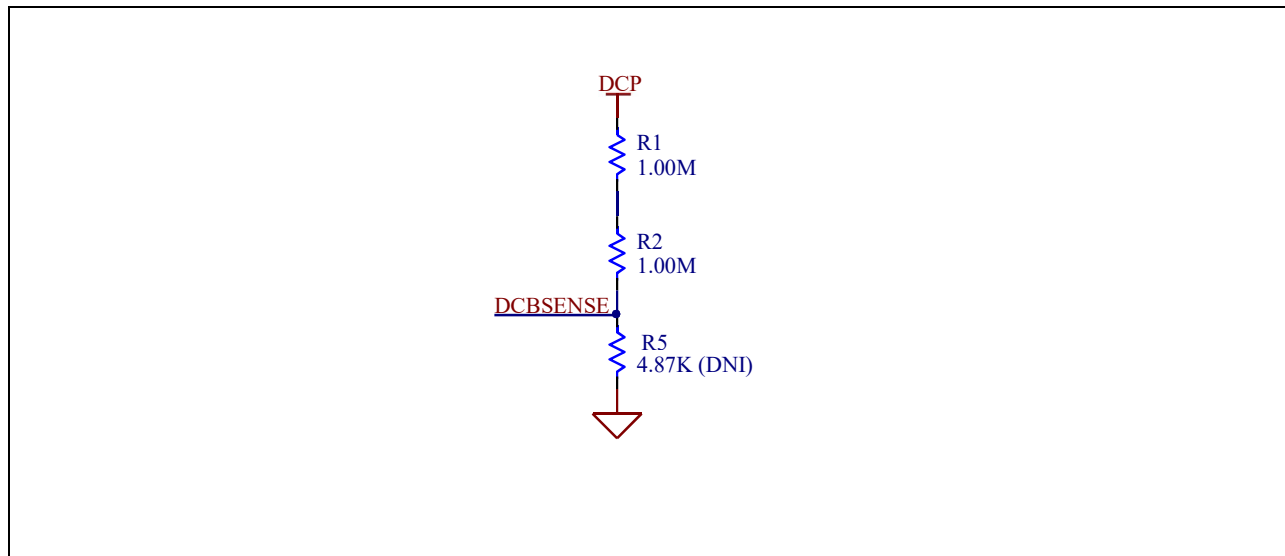

Figure 11 DC bus sense resistors in EVAL-M1-36-44A evaluation board

Schematics and Layout

6.2 Inverter section using CIPOS™ Nano IPM

The inverter section is implemented using the CIPOS™ as displayed in Figure 12. The module includes six power MOSFETs and three half bridge gate drivers.

The three capacitors C71, C72 and C73 are used as bootstrap capacitors to provide the necessary floating supply voltages V_{BS1} , V_{BS2} and V_{BS3} respectively.

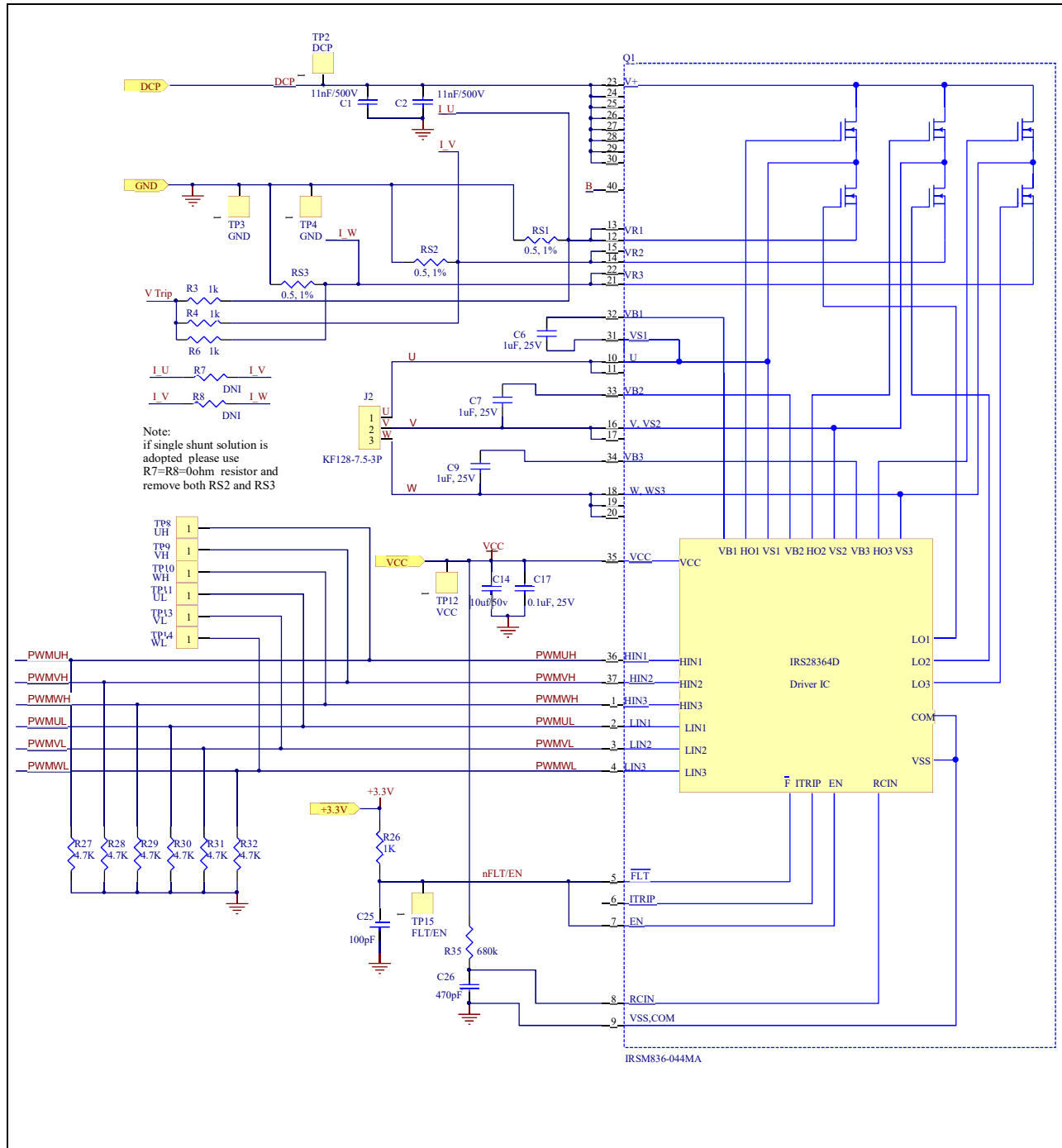

Figure 12 Schematic of the 3-phase inverter section using CIPOS™ Nano IPM on EVAL-M1-36-44A board

Schematics and Layout

6.3 Current Measurement and Over Current Circuit

The resistors RS1 to RS3 are purposed to generate a voltage proportional to the emitter current. These voltages are available at 20 pin interface connector to give feedback to the controller. In combination with resistors R70 to R72 they are used to generate common current signal V_TRIP for all three phases. V_TRIP is always on highest level of all three phase current. This signal is used to generate gate-kill signal I_TRIP.

Figure 13 is the over current circuitry shown. Capacitor C32 and resistor R39 are filtering voltage spikes and noise on V_TRIP to avoid incident turn off.

The comparator threshold can be set through the voltage divider provided by resistors R36 and R40. By default for emitter-shunt trip, R40 is 3.2kΩ.

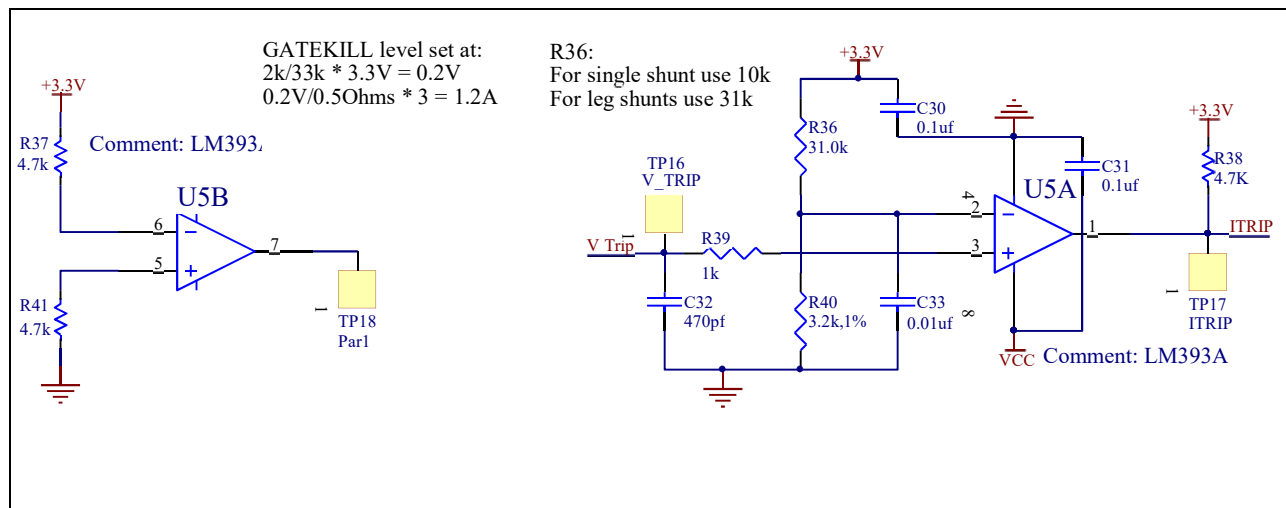

Figure 13 Over current protection circuit on the EVAL-M1-36-44A evaluation board

Schematics and Layout

6.4 Auxiliary Power supply

Figure 14 depicts the schematic of the auxiliary power supply for the EVAL-M1-36-44A board. The circuit includes the latest CoolSET 5 of Infineon and flyback topology, directly output 15V and 6V. V_{CC} is connected to the gate drivers inside the CIPOS™ IPM.

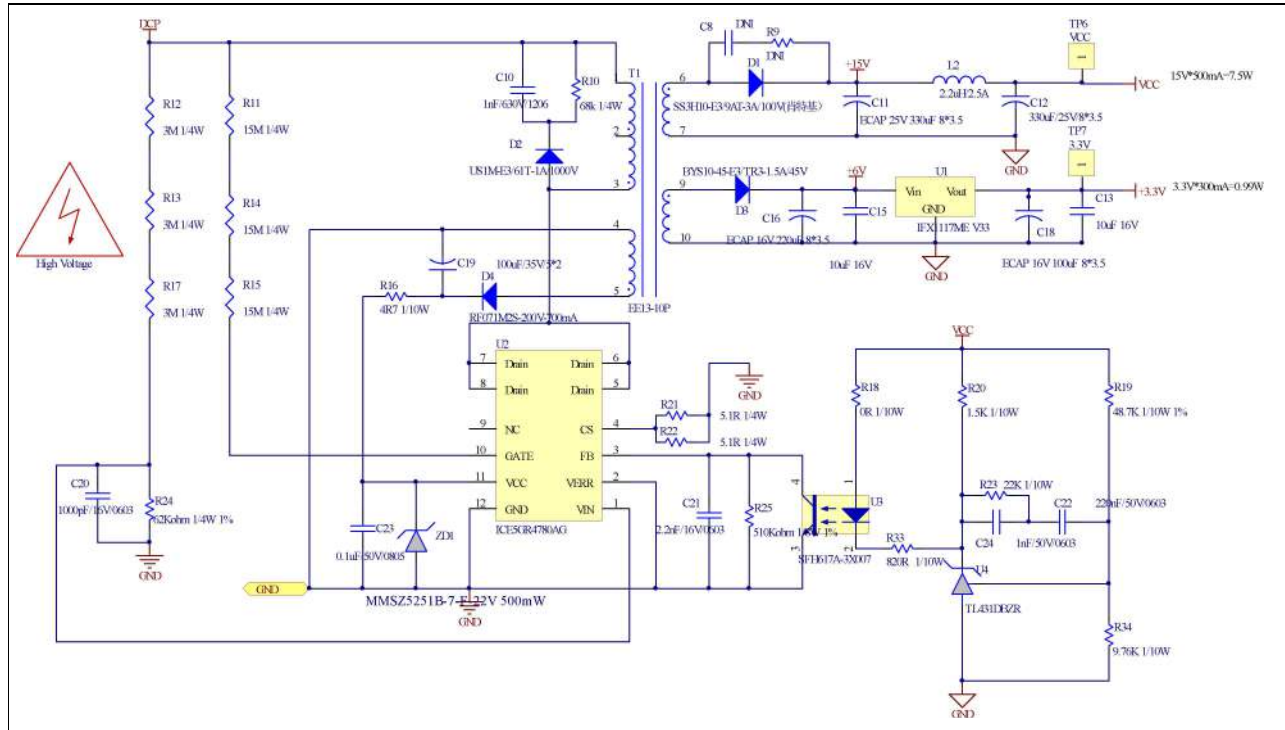

Figure 14 Power supply section of the EVAL-M1-36-44A evaluation board

The linear voltage regulator IFX117ME V33 generates 3.3 V from 6 V power supply V_{CC} . The 3.3 V power supply is used in the inverter external overcurrent comparator circuit and over temperature hardware protection circuit. Both V_{CC} and 3.3 V are also present on the 20 pins iMOTION™ MADK-M1 interface connector J3 to power circuitry on the control board.

Schematics and Layout

6.5 PCB Layout

The layout of this board can be used for different voltage or power classes. The power PCB is a two layer PCB. Get in contact with our technical support team to get more detailed information and the latest Gerber-files.

Figure 15 illustrates the top assembly print of the evaluation board.

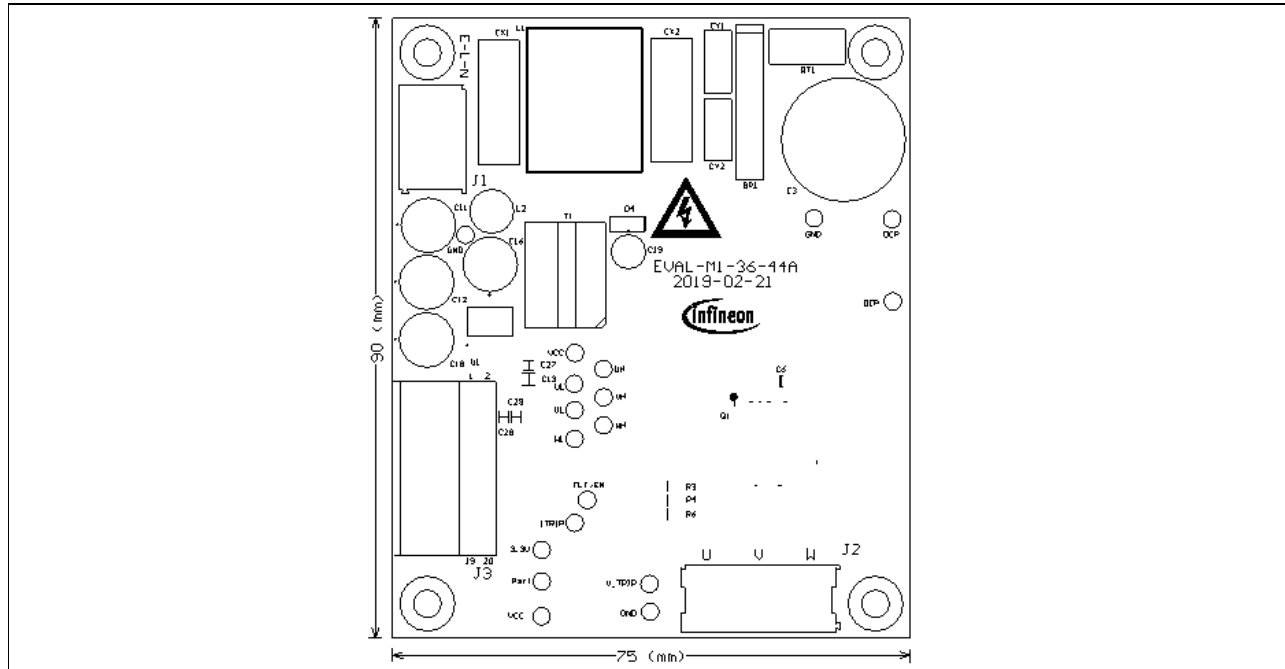

Figure 15 Top assembly print of the EVAL-M1-36-44A evaluation board

Figure 16 depicts the bottom assembly print of the evaluation board.

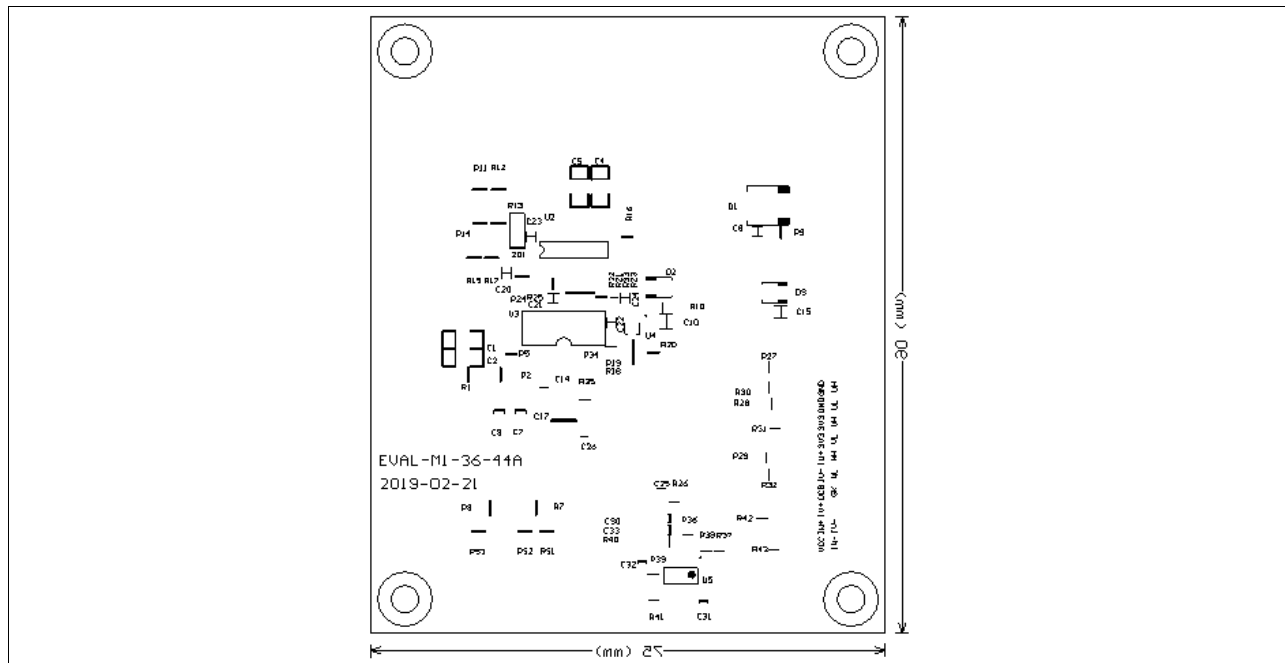

Figure 16 Bottom assembly print of the EVAL-M1-36-44A evaluation board

Schematics and Layout

The top layer routing of the PCB is provided in Figure 17 .

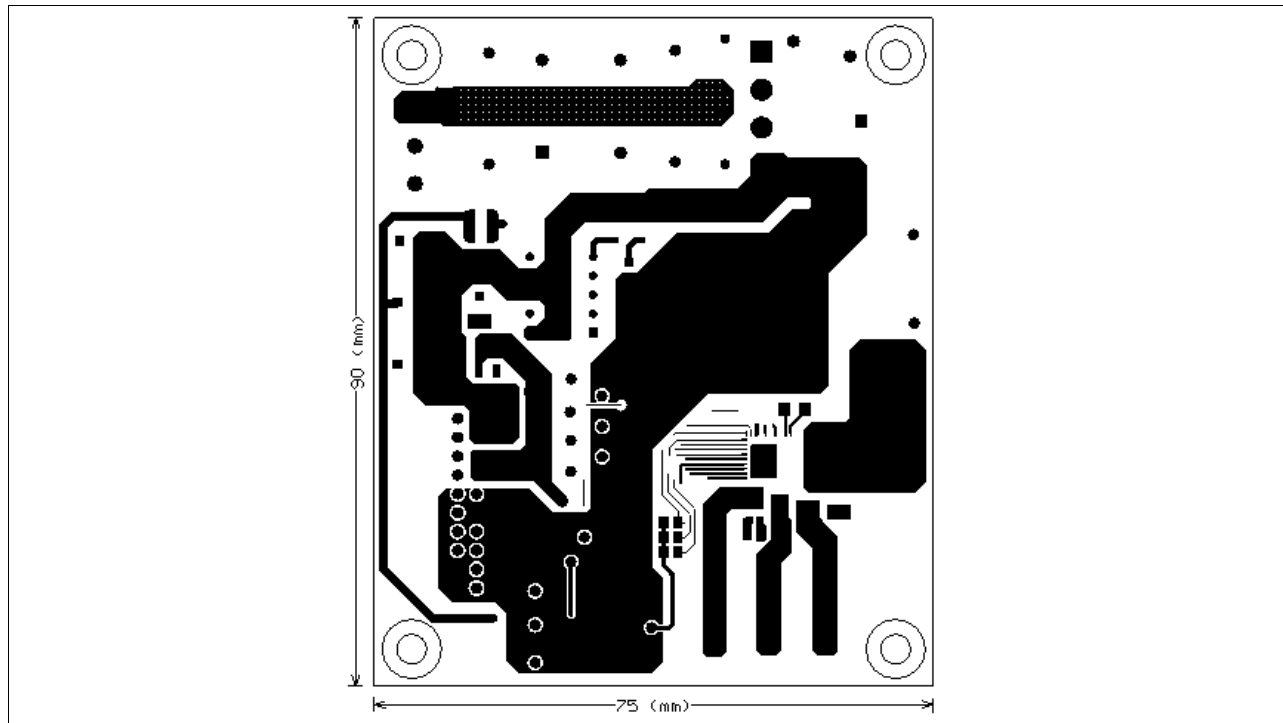

Figure 17 Top layer routing details of EVAL-M1-36-44A

Figure 18 illustrates the bottom layer routing details.

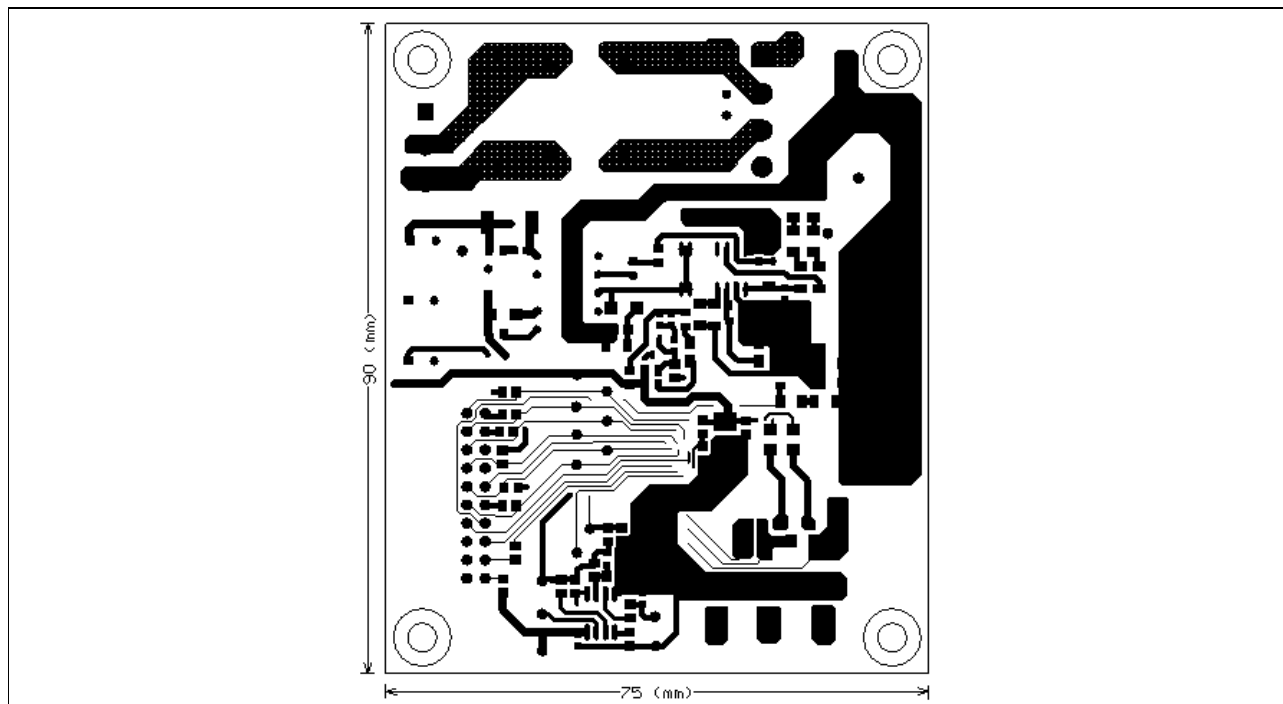

Figure 18 Bottom layer routing details of EVAL-M1-36-44A

7 Bill of Materials of EVAL-M1-36-44A

Table 9 provides the complete bill of materials of the evaluation board.

Table 9 Bill of materials

No.	Qty	Part description	Designator	Part number	Manufacturer
1	1	RECT BRIDGE GPP 4A 600V GBU	BR1	GBU406	DIODES INCORPORATED
2	4	CAP CER 0.012μF 500V X7R 1206	C1, C2, C4, C5	1206J5000123MDR	Knowles Syfer
3	1	CAP ALUM 100μF 20% 400V RADIAL	C3	860021380020	Wurth Electronics Inc.
4	3	CAP CER 1μF 25V X7R 0805	C6, C7, C9	885012207078	Wurth Electronics Inc.
5	1	CAP SMD 470pF 100V 0603(DNI)	C8	885012006083	Wurth Electronics Inc.
6	1	CAP SMD 1nF 630V 1206	C10	885342008005	Wurth Electronics Inc.
7	2	CAP ALUM100μF 20% 16V RADIAL	C11, C18	860010372006	Wurth Electronics Inc.
8	1	CAP ALUM330μF 20% 25V RADIAL	C12	860020474013	Wurth Electronics Inc.
9	2	CAP CER 10μF 16V X5R 0805	C13, C15	885012107014	Wurth Electronics Inc.
10	1	CAP TANT 10UF 10% 50V 2917	C14	T491D106K050AT	KEMET
11	1	ECAP ALUM 220μF 16V RADIAL	C16	860080374009	Wurth Electronics Inc.
12	1	CAP CER 0.1μF 25V X7R 0805	C17	885012207072	Wurth Electronics Inc.
13	1	CAP ALUM 100μF 20% 35V RADIAL	C19	860020573008	Wurth Electronics Inc.
14	1	CAP CER 1000pF 16V 0603	C20	885012206034	Wurth Electronics Inc.
15	1	CAP CER 2200pF 16V X7R 0603	C21	885012206036	Wurth Electronics Inc.
16	1	CAP CER 220nF 16V 0603	C22	885012206048	Wurth Electronics Inc.
17	1	CAP CER 0.1μF 50V X7R 0805	C23	885012207098	Wurth Electronics Inc.
18	1	CAP CER 1000PF 50V C0G/NP0 0805	C24	885012007063	Wurth Electronics Inc.
19	1	CAP CER 470pF 50V X7R 0805	C26	885012007061	Wurth Electronics Inc.
20	2	CAP CER 0.1μF 50V X7R 0603	C30, C31	885012206095	Wurth Electronics Inc.
21	1	CAP CER 100pF 50V X7R 0805	C25	885012207080	Wurth Electronics Inc.
22	1	CAP CER 470pF 50V X7R 0603	C32	885012006061	Wurth Electronics Inc.
23	3	CAP CER 0.1μF 25V X7R 0603	C27, C28, C29	885012206071	Wurth Electronics Inc.
24	1	CAP CER 10000pF 50V X7R 0603	C33	885012206089	Wurth Electronics Inc.
25	2	CAP FILM 0.1μF 20% 275VAC RADIAL	CX1, CX2	890324025017CS	Wurth Electronics Inc.
26	2	CAP CER 2200pF 250VAC RADIAL	CY1, CY2	DE2E3KY222MN3A M02F	MURATA ELECTRONICS
27	1	DIODE Schottky 100V 3A DO214AB	D1	SS3H10-E3/9AT	Vishay
28	1	DIODE FRD 1000V 1A DO241AC	D2	US1M-E3/61T	Vishay

Bill of Materials of EVAL-M1-36-44A

No.	Qty	Part description	Designator	Part number	Manufacturer
29	1	DIODE Schottky 45V 1.5A DO214AC	D3	BYS10-45-E3/TR3	Vishay
30	1	RF071M2S-200V-700mA	D4	RF071MM2STR	ROHM
31	1	SERIE 2165S - 5.08 MM - HORIZONTAL CABLE ENTRY WITH RISING CAGE CLAMP - WR-TBL	J1	691216510003S	Würth Electronics Inc.
32	1	SERIE 2169 - 7.50 MM - HORIZONTAL CABLE ENTRY WITH RISING CAGE CLAMP - WR-TBL	J2	691216910003	Würth Electronics Inc.
33	1	2.54MM ANGLED DUAL SOCKET HEADER	J3	613020243121	Würth Electronics Inc.
34	1	8103-RC	L1	JWMILLER_8103	Bourns, Inc.
35	1	FIXED IND 2.2UH 2.5A 71 MOHM SMD	L2	744773022	Würth Electronics Inc.
36	1	RES SMD 4.87 kΩ 1% 1/8W 0805 (DIN)	R5	RC0805FR- 074K87L	Yageo
37	2	RES SMD 1 MΩ 1% 1/4W 1206	R1, R2	RCL06121M00JNE A	Yageo
38	5	RES SMD 1kΩ 1% 1/8W 0805	R3, R4, R6, R26, R39	RC0805FR-071KL	Yageo
39	1	RES SMD 680kΩ 5% 1/8W 0805	R35	RC0805JR- 07680KL	Yageo
40	9	RES SMD 4.7 kΩ 1% 1/8W 0805	R27, R28, R29, R30, R31, R32, R37, R38, R41	RC0805FR-074K7L	Yageo
41	1	RES THICK FILM SMD 0805 1% 31kΩ	R36	RC0805FR- 0731K6L	Yageo
42	1	RES SMD 2kΩ 1% 1/8W 0805	R40	RC0805FR-072KL	Yageo
43	1	RES SMD 68K OHM 5% 1/8W 0805	R10	RC0805JR-0768KL	Yageo
44	3	RES SMD 15MΩ 5% 1/4W 1206	R11, R14, R15	RC1206JR-0715ML	Yageo
45	3	RES SMD 3M OHM 5% 1/4W 1206	R12, R13, R17	RC1206JR-073ML	Yageo
46	3	RES SMD 0 Ω JUMPER 1/8W 0805	R18, R42, R43	0805J0000T5E	Yageo
47	1	RES SMD 4.7Ω 1% 1/8W 0805	R16	RC0805FR-074R7L	Yageo
48	1	RES SMD 4.87 kΩ 1% 1/8W 0805	R19	RC0805FR- 074K87L	Yageo
49	1	RES SMD 1.5kΩ 1% 1/8W 0805	R20	RC0805JR-071K5L	Yageo
50	2	RES SMD 5.1Ω 1% 1/4W 1206	R21,R22	RC1206FR-075R1L	Yageo
51	1	RES SMD 22kΩ 5% 1/8W 0603	R23	RC0805JR-0722KL	Yageo
52	1	RES SMD 62kΩ 5% 1/4W 1206	R24	RC1206FR-0762KL	Yageo
53	1	RES SMD 510kΩ 1% 1/8W 0805	R25	RC0805FR- 07510KL	Yageo
54	1	RES SMD 820Ω 1% 1/8W 0805	R33	RC0805JR- 07820RL	Yageo

Bill of Materials of EVAL-M1-36-44A

No.	Qty	Part description	Designator	Part number	Manufacturer
55	1	RES SMD 9.76kΩ 1% 1/8W 0805	R34	RC0805FR-079K76L	Yageo
56	3	RES SMD 0.5Ω 1% 1/4W 1206	RS1, RS2, RS3	RL1206FR-070R5L	Yageo
57	1	NTC 15Ω 9MM DIA	RT1	NTC15D-9	SHIN-HANG
58	1	Transformer EE13-10P	T1	750344226	Würth Electronics Inc.
59	18	T TEST POINT PC MINI .040"D WHITE	TP1, TP4, TP2, TP3, TP5, TP6, TP7, TP8, TP9, TP10, TP11, TP12, TP13, TP14, TP15, TP16, TP17, TP18,	5002	KEYSTONE ELECTRONICS
60	1	IC MOTOR DRIVER PAR 37-PQFN	Q1	IRSM836-044MA	Infineon Technologies
61	1	IC REG LINEAR 3.3V 1A SOT223-4	U1	IFX1117MEV33HTM A1	Infineon Technologies
62	1	IC AUX Power PD-DSO-12	U2	ICE5GR4780AG	Infineon Technologies
63	1	IC Opto Coupler	U3	SFH617A-3X007	Vishay
64	1	IC TL431DBZR	U4	TL431DBZR	Texas Instruments
65	1	IC DUAL DIFF COMPARATOR 8-SOIC	U5	LM393ADR	Texas Instruments
66	1	DIODE ZENER 22V 500mW SOD123	ZD1	MMSZ525B-7-F	Würth Electronics Inc.

8 Reference

- [1] Datasheet of Infineon IPM IRSM836-044MA, is available for download on Infineon's website
- [2] 2018-11_AN2018-36_EVAL-M1-IM231-A User Manual_V1.0_EN
- [3] EVAL-M1-101T User Manual is available for download on Infineon's website
- [4] EVAL-M1-183M User Manual is available for download on Infineon's website

Note: All listed reference materials are available for download on Infineon's website
www.infineon.com/. All the iMOTION MADK evaluation board's User Manuals are available at
www.infineon.com/MADK



Revision History

Revision History

Major changes since the last revision

Version number	Revision Date	Revision description
1.0	2019-07-25	First release

Trademarks of Infineon Technologies AG

μHVIC™, μIPM™, μPFC™, AU-ConvertIR™, AURIX™, C166™, CanPAK™, CIPOS™, CIPURSE™, CoolDP™, CoolGa™, COOLiR™, CoolMOS™, CoolSET™, CoolSiC™, DAVE™, DI-POL™, DirectFET™, DrBlade™, EasyPIM™, EconoBRIDGE™, EconoDUAL™, EconoPACK™, EconoPIM™, EiceDRIVER™, eupec™, FCOS™, GaNpowIR™, HEXFET™, HITFET™, HybridPACK™, iMOTION™, IRAM™, ISOFACE™, IsoPACK™, LEDriviR™, LITIX™, MIPAQ™, ModSTACK™, my-d™, NovalithIC™, OPTIGA™, OptiMOS™, ORIGA™, PowIRaudio™, PowIRstage™, PrimePACK™, PrimeSTACK™, PROFET™, PRO-SIL™, RASIC™, REAL3™, SmartLEWIS™, SOLID FLASH™, SPOC™, StrongIRFET™, SuplRBuck™, TEMPFET™, TRENCHSTOP™, TriCore™, UHVIC™, XHP™, XMC™

Trademarks updated November 2015

Other Trademarks

All referenced product or service names and trademarks are the property of their respective owners.

Edition 2019-07-25

Published by

Infineon Technologies AG

81726 Munich, Germany

© 2019 Infineon Technologies AG.

All Rights Reserved.

Do you have a question about this document?

Email: erratum@infineon.com

Document reference

AN2019-03 EVAL-M1-36-44A User Manual

IMPORTANT NOTICE

The information contained in this application note is given as a hint for the implementation of the product only and shall in no event be regarded as a description or warranty of a certain functionality, condition or quality of the product. Before implementation of the product, the recipient of this application note must verify any function and other technical information given herein in the real application. Infineon Technologies hereby disclaims any and all warranties and liabilities of any kind (including without limitation warranties of non-infringement of intellectual property rights of any third party) with respect to any and all information given in this application note.

The data contained in this document is exclusively intended for technically trained staff. It is the responsibility of customer's technical departments to evaluate the suitability of the product for the intended application and the completeness of the product information given in this document with respect to such application.

For further information on the product, technology delivery terms and conditions and prices please contact your nearest Infineon Technologies office (www.infineon.com).

Please note that this product is not qualified according to the AEC Q100 or AEC Q101 documents of the Automotive Electronics Council.

WARNINGS

Due to technical requirements products may contain dangerous substances. For information on the types in question please contact your nearest Infineon Technologies office.

Except as otherwise explicitly approved by Infineon Technologies in a written document signed by authorized representatives of Infineon Technologies, Infineon Technologies' products may not be used in any applications where a failure of the product or any consequences of the use thereof can reasonably be expected to result in personal injury.