

DO NOT SCALE FROM THIS PRINT

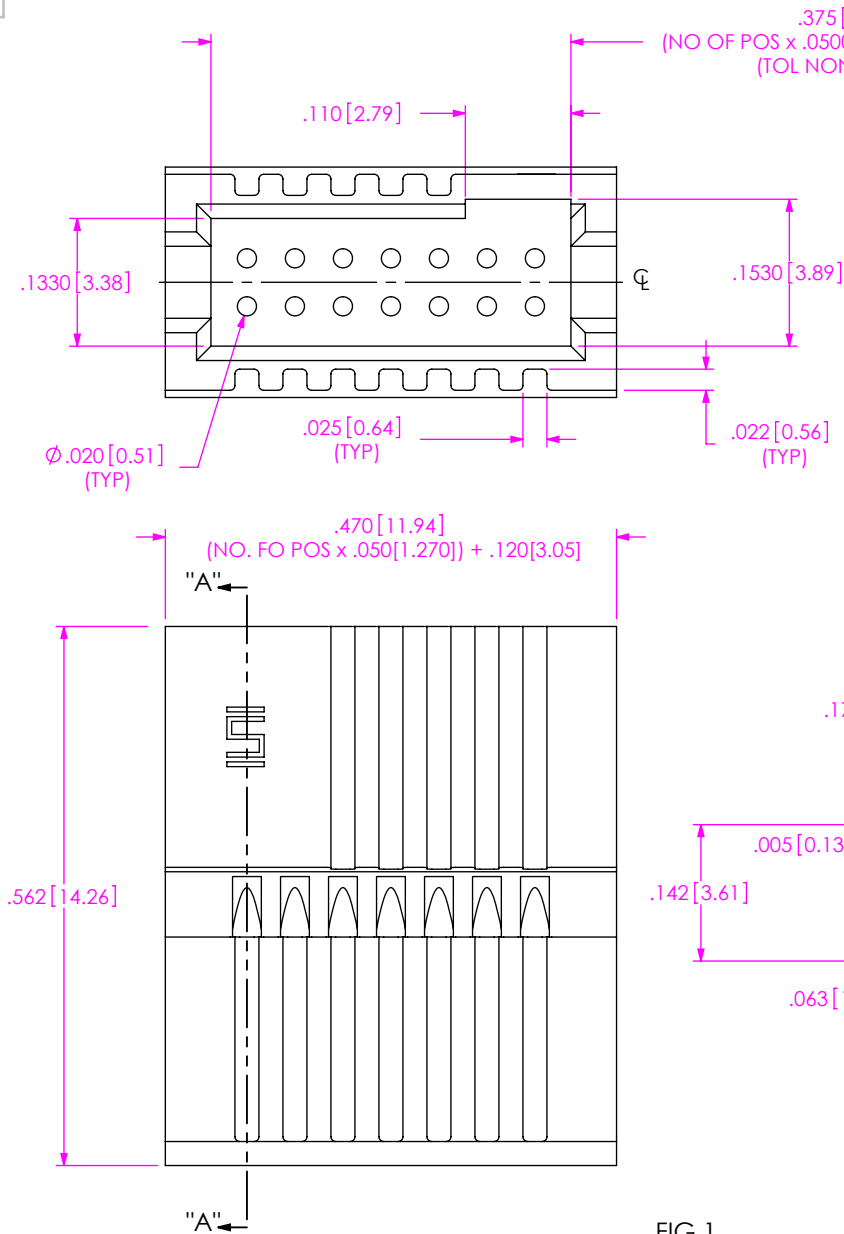

FIG 1
TFSDF-07-D-S SHOWN

TSDf-XX-X-S-X

No OF POSITIONS
-02 THRU -50
(PER ROW)

ROW SPECIFICATION
-D: DOUBLE ROW
-S: SINGLE ROW

LOCK OPTION
LEAVE BLANK: NO LOCK
-L: FRICTION LOCK
(ONLY AVAILABLE ON
DOUBLE ROW & POS
-05, -07 & -10 THRU -50)
(SEE FIG 3, SHEET 3)
(SEE NOTE 3)

SHROUD SPECIFICATION
-S: SHROUD

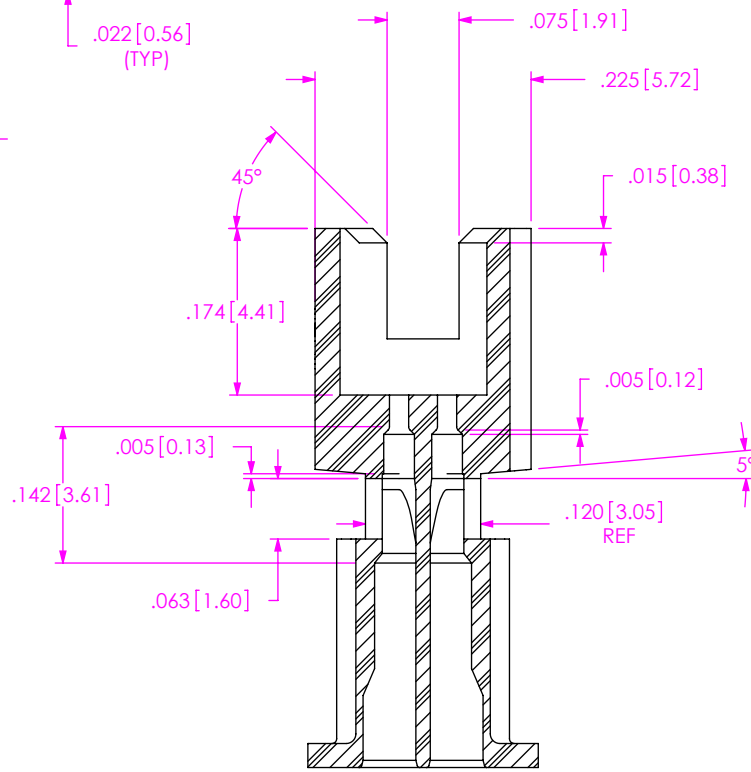

SECTION "A"-"A"
SCALE 5:1

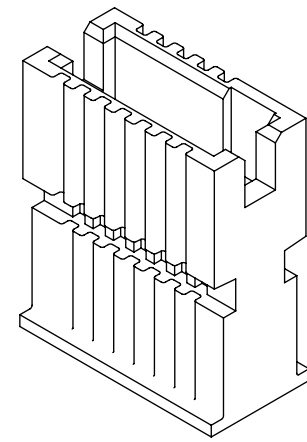

NOTES:

- ⊙ REPRESENTS A CRITICAL DIMENSION.
- PARTS TO BE BULK PACKAGED IN BAGS.
- POSITIONS -05, -07 & -10 THRU -24 WILL HAVE ONLY ONE CLIP AT DIMENSION SHOWN. POSITIONS -25 THRU -50 WILL HAVE TWO CLIPS AT DIMENSION SHOWN.

<p>UNLESS OTHERWISE SPECIFIED, DIMENSIONS ARE IN INCHES. TOLERANCES ARE:</p> <p>DECIMALS ANGLES</p> <p>.XX: ±.01 [0.3] 2°</p> <p>.XXX: ±.003 [0.08]</p> <p>.XXXX: ±.0015 [0.038]</p>	<p>PROPRIETARY NOTE</p> <p>THIS DOCUMENT CONTAINS CONFIDENTIAL AND PROPRIETARY INFORMATION AND ALL DESIGN, MANUFACTURING, REPRODUCTION, USE, PATENT RIGHTS AND SALES RIGHTS ARE EXPRESSLY RESERVED BY SAMTEC, INC. THIS DOCUMENT SHALL NOT BE DISCLOSED, IN WHOLE OR PART, TO ANY UNAUTHORIZED PERSON OR ENTITY NOR REPRODUCED, TRANSFERRED OR INCORPORATED IN ANY OTHER PROJECT IN ANY MANNER WITHOUT THE EXPRESS WRITTEN CONSENT OF SAMTEC, INC.</p>	 <p>520 PARK EAST BLVD, NEW ALBANY, IN 47150 PHONE: 812-944-6733 FAX: 812-948-5047 e-Mail: info@SAMTEC.com code: 55322</p>
<p>BY: J. BROWNING 10/04/07 SHEET 1 OF 3</p>		

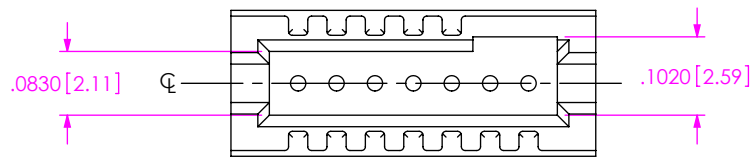

$.475 [12.07]$
 (NO. OF POS x $.0500 [1.270]$) + $.125 [3.18]$

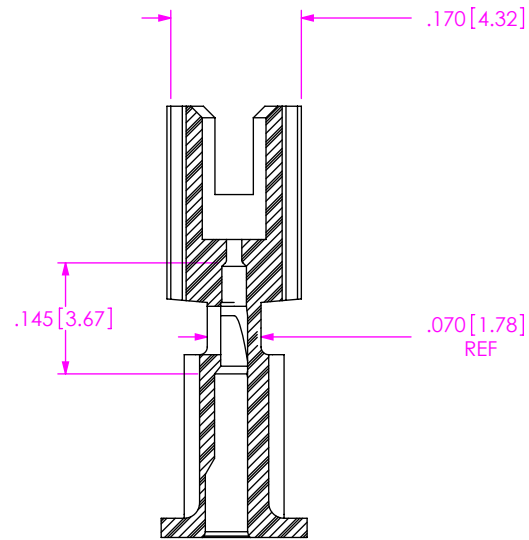
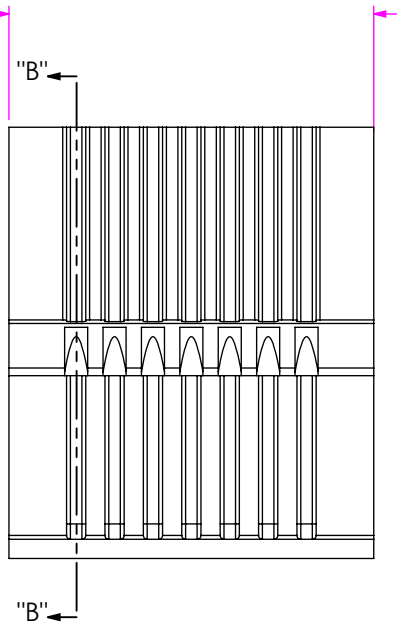

SECTION "B"- "B"

FIG 2
 TFSD-07-S-S SHOWN
 (DIFFERENT AS SHOWN, OTHERWISE SAME AS FIG 1)

PROPRIETARY NOTE
 * THIS DOCUMENT CONTAINS CONFIDENTIAL AND PROPRIETARY INFORMATION AND ALL DESIGN, MANUFACTURING, REPRODUCTION, USE, PATENT RIGHTS AND SALES RIGHTS ARE EXPRESSLY RESERVED BY SAMTEC, INC. THIS DOCUMENT SHALL NOT BE DISCLOSED, IN WHOLE OR PART, TO ANY UNAUTHORIZED PERSON OR ENTITY NOR REPRODUCED, TRANSFERRED OR INCORPORATED IN ANY OTHER PROJECT IN ANY MANNER WITHOUT THE EXPRESS WRITTEN CONSENT OF SAMTEC, INC.

DO NOT SCALE DRAWING

SHEET SCALE: 4:1

samtec

520 PARK EAST BLVD, NEW ALBANY, IN 47150
 PHONE: 812-944-6733 FAX: 812-948-5047
 e-Mail: info@SAMTEC.com code: 55322

DESCRIPTION:
 .050" CL CRIMP WIRE SOCKET INSULATOR

DWG. NO. TSDF-XX-X-S-X

BY: J. BROWNING 10/04/07 SHEET 2 OF 3

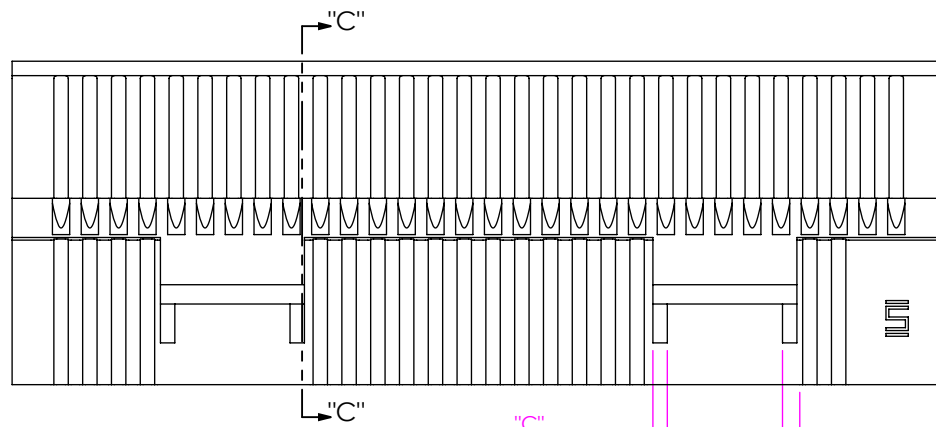
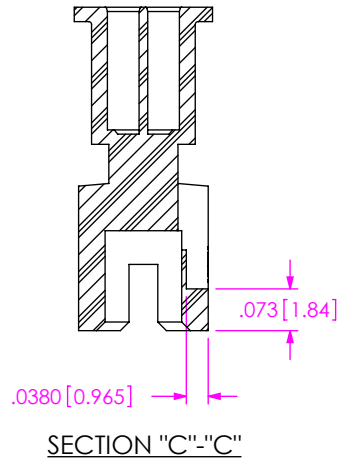

"C"
(SEE TABLE 1)

"B"
(SEE TABLE 1)

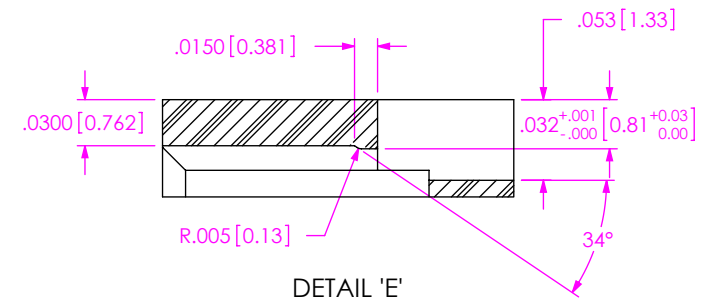
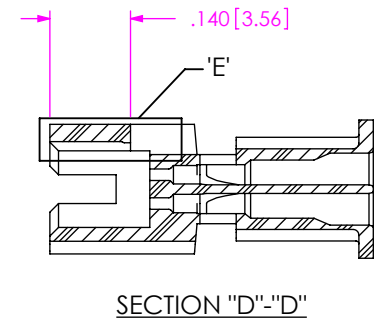
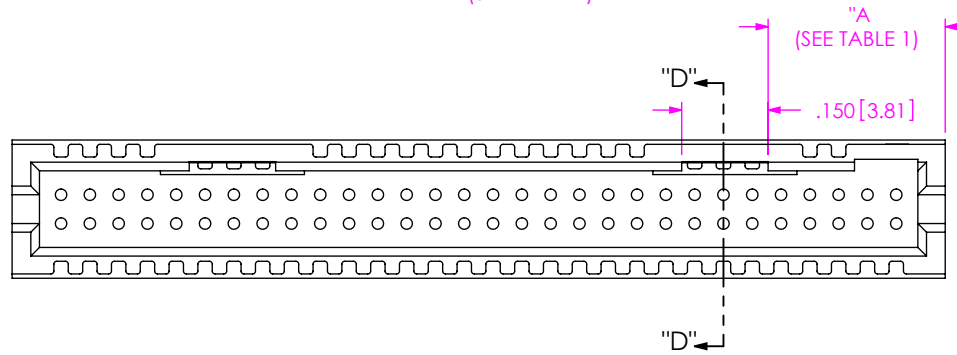

FIG 3
-L: FRICTION LOCK OPTION
TFSD-30-D-S-L SHOWN
(ONLY AVAILABLE ON DOUBLE ROW &
POSITIONS -05, -07, & -10 THRU -50)
(SAME AS FIG. 1 UNLESS SPECIFIED)
(SEE NOTE 3)

TABLE 1

No. OF POS.	"A"	"B"	"C"
EVEN	.308	.200	.250
ODD (EXCL. -05 & -07 POS)	.358	.200	.250
-05 & -07	.111	.175	.225

PROPRIETARY NOTE
THIS DOCUMENT CONTAINS CONFIDENTIAL AND PROPRIETARY INFORMATION AND ALL DESIGN, MANUFACTURING, REPRODUCTION, USE, PATENT RIGHTS AND SALES RIGHTS ARE EXPRESSLY RESERVED BY SAMTEC, INC. THIS DOCUMENT SHALL NOT BE DISCLOSED, IN WHOLE OR PART, TO ANY UNAUTHORIZED PERSON OR ENTITY NOR REPRODUCED, TRANSFERRED OR INCORPORATED IN ANY OTHER PROJECT IN ANY MANNER WITHOUT THE EXPRESS WRITTEN CONSENT OF SAMTEC, INC.

DO NOT SCALE DRAWING

SHEET SCALE: 3:1



520 PARK EAST BLVD, NEW ALBANY, IN 47150
PHONE: 812-944-6733 FAX: 812-948-5047
e-Mail: info@SAMTEC.com code: 55322

DESCRIPTION:
.050" CL CRIMP WIRE SOCKET INSULATOR

DWG. NO. TSDF-XX-X-S-X

BY: J. BROWNING 10/04/07 SHEET 3 OF 3