

PRODUCT NUMBER
SEE TABLE

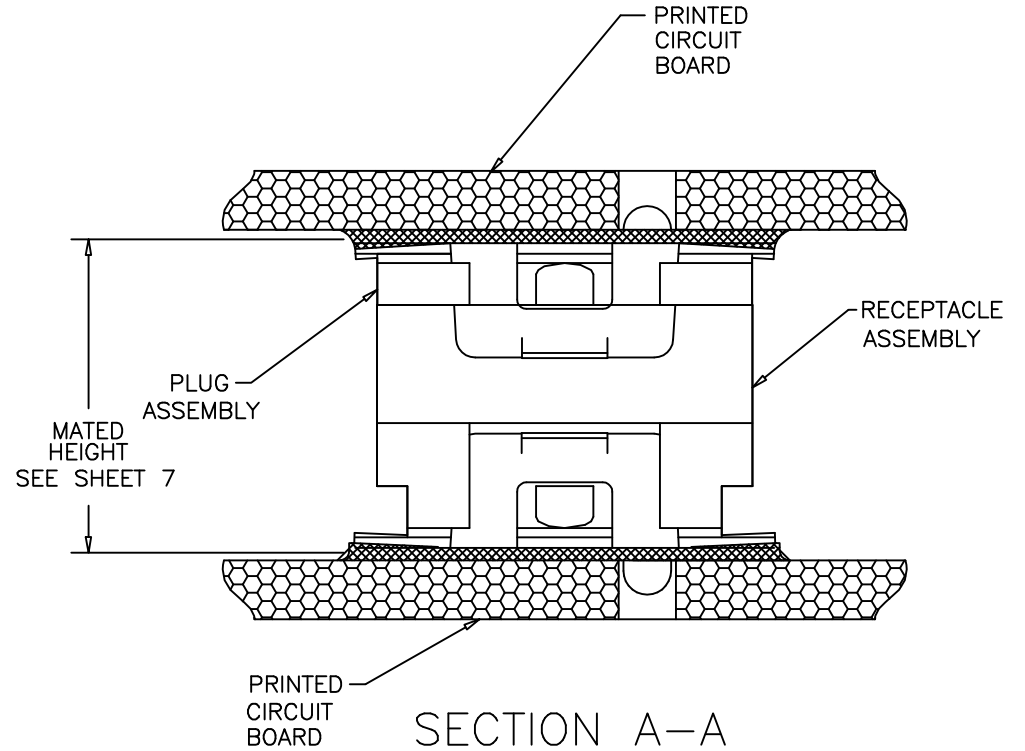
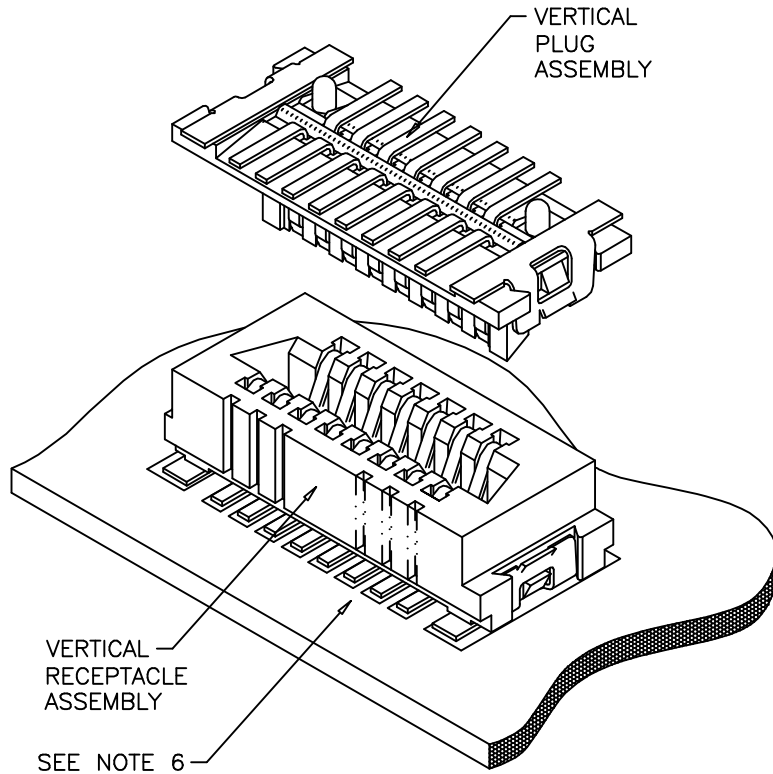

SECTION A-A
ROTATED 90°
N.T.S.

FCIconnect.com

Copyright FCI

mat'l. code		surface ISO 1302		tolerance ISO 406 ISO 1101		projection INCH/MM		product family CONAN®	
ltr		ecn no		dr		date		title	
A		-		GM		2013-01-14		CONAN® CONNECTOR ASSEMBLY	
B		ELX-N-13992		GM		2013-02-05		dwg no	
C		ELX-N-14209		GM		2013-03-07		10124017	
				dr		GM SUN		sheet 1 of 7	
				engr		GM SUN		size	
				chr		RICK BIAN		A3	
				appd		RICK BIAN		type	
								Product Customer Drawing	
sheet index		revision sheet		C		C		C	
		1		2		3		4	
		5		6		7			

PRODUCT NUMBER
SEE TABLE

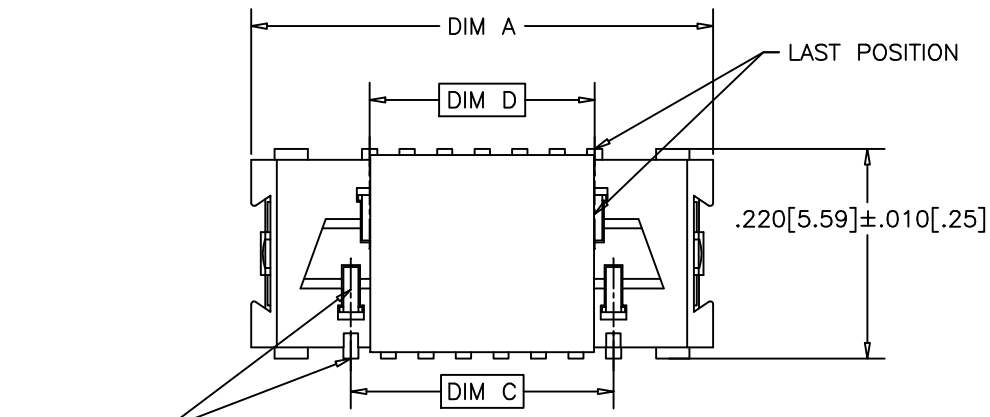

RECEPTACLE

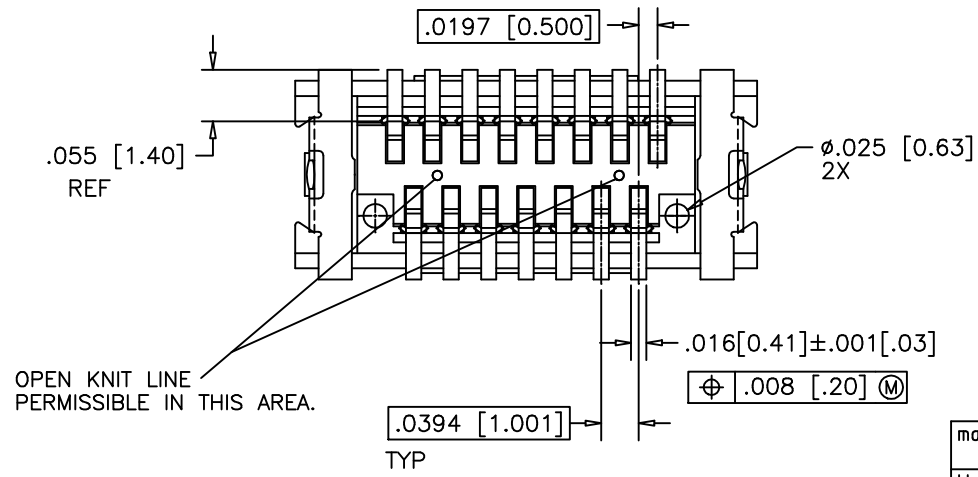
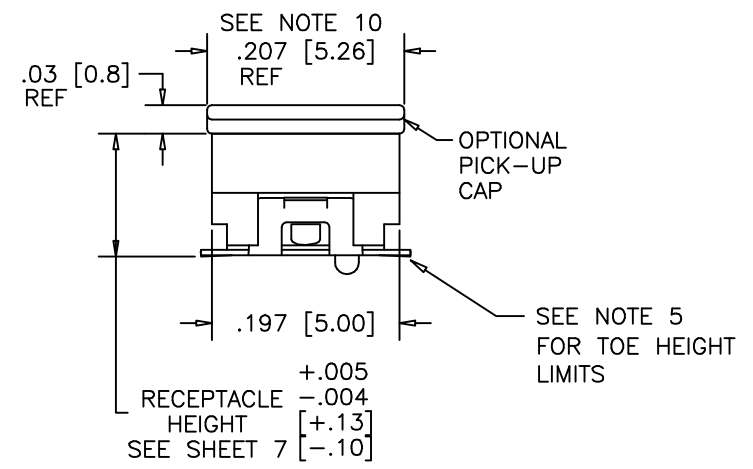
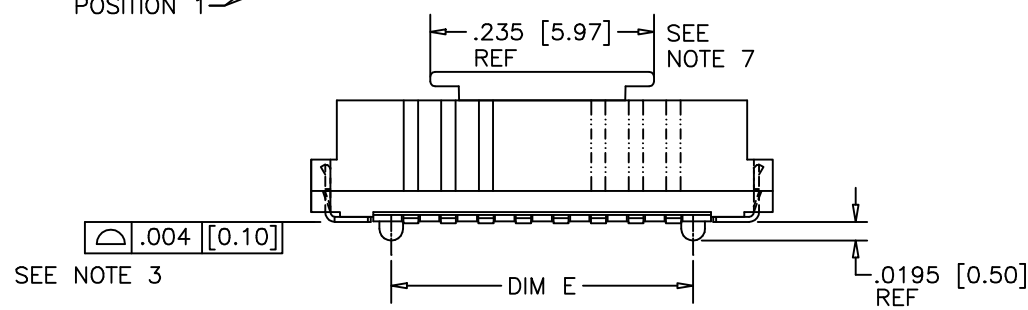

mat'l. code		surface ISO 1302 ✓	tolerance ISO 406 ISO 1101	projection INCH/MM	product family CONAN®
ltr	ecn no	dr	date	tolerances unless otherwise specified	title CONAN® CONNECTOR ASSEMBLY
c				linear XXX±.01/XX±0.3 XXX±.005/XX±0.13 XXXX±.0020/XXX±0.05	
				angles 0°±2'	scale 5:1
		dr	GM SUN	2013-01-14	
		enr	GM SUN	2013-01-14	
		chr	RICK BIAN	2013-01-14	
		appd	RICK BIAN	2013-01-14	
sheet index	revision sheet				dwg no 10124017 sheet 2 of 7 size A3 type Product Customer Drawing



Copyright FCI

PRODUCT NUMBER
SEE TABLE

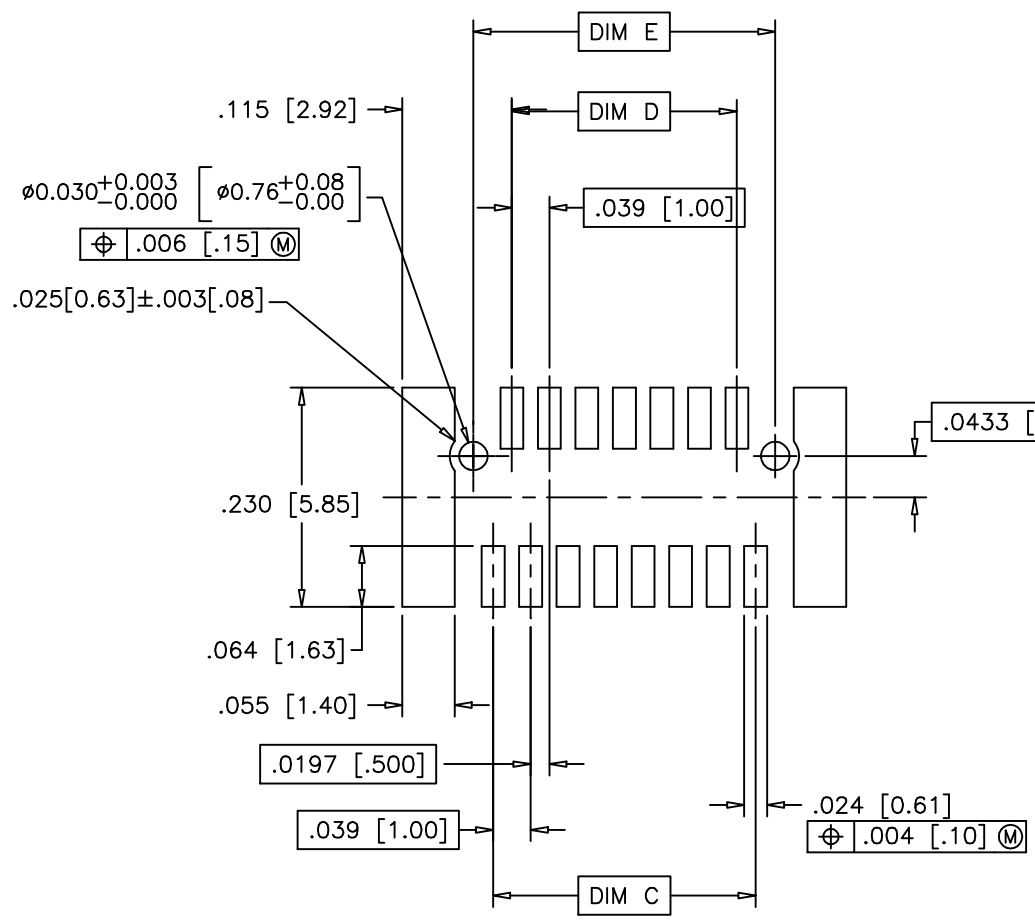

RECOMMENDED
PAD LAYOUT
FOR RECEPTACLE

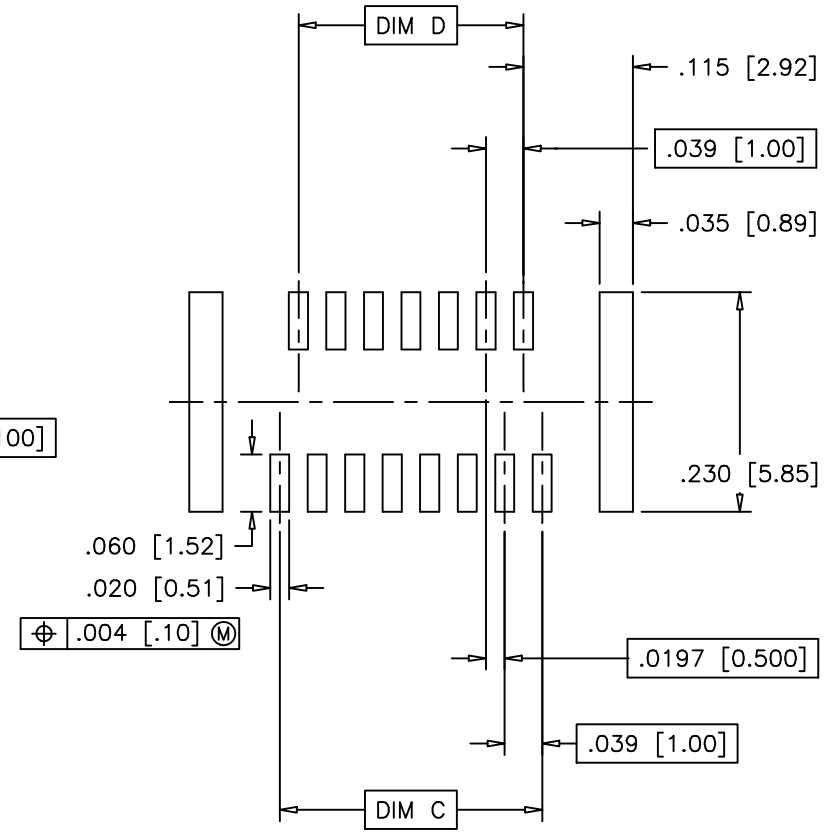

RECOMMENDED
STENCIL LAYOUT
FOR RECEPTACLE

mat'l. code		surface ISO 1302 <input checked="" type="checkbox"/>		tolerance ISO 406 <input checked="" type="checkbox"/> ISO 1101		projection		product family CONAN®	
ltr		ecn no		dr		date		title	
c								CONAN® CONNECTOR ASSEMBLY	
				angles linear		tolerances unless otherwise specified XXX±.01/XX±0.3 XXX±.005/XX±0.13 XXXX±.0020/XXX±0.05		INCH/MM	
				0°±2'				scale 5:1	
				dr		GM SUN		2013-01-14	
				engr		GM SUN		2013-01-14	
				chr		RICK BIAN		2013-01-14	
				appd		RICK BIAN		2013-01-14	
sheet index		revision sheet						dwg no 10124017	
								sheet 3 of 7 size A3	
								type Product Customer Drawing	



Copyright FCI

PRODUCT NUMBER
SEE TABLE

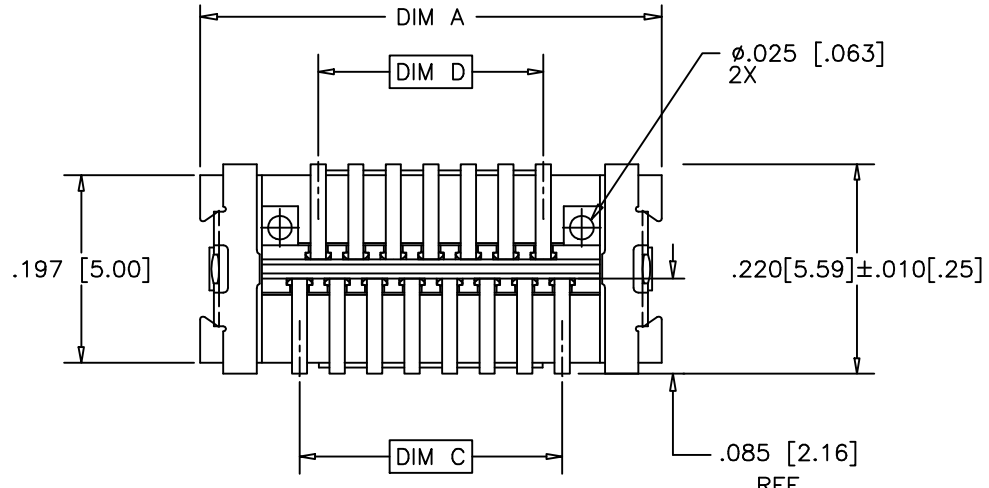

PLUG

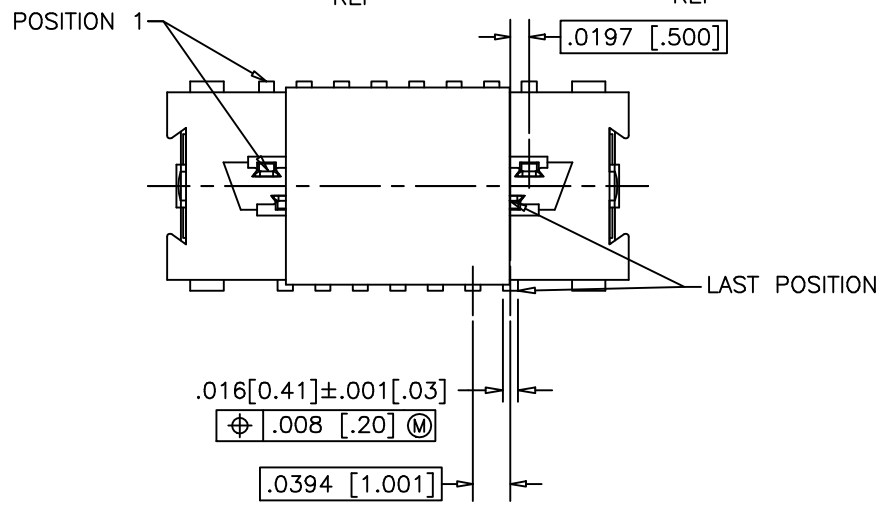
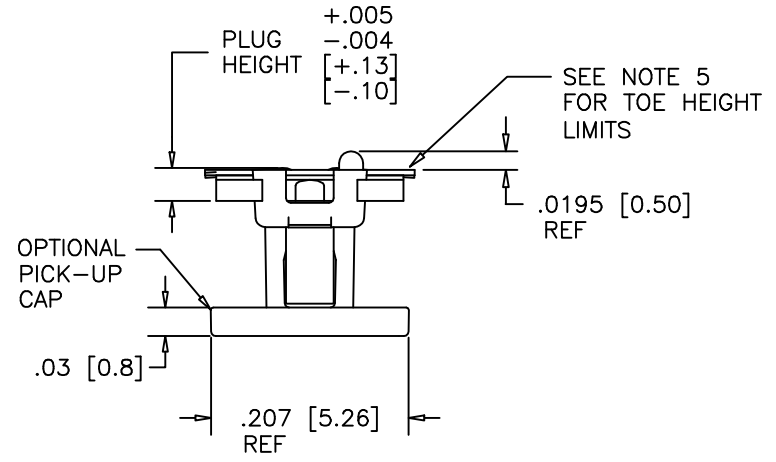
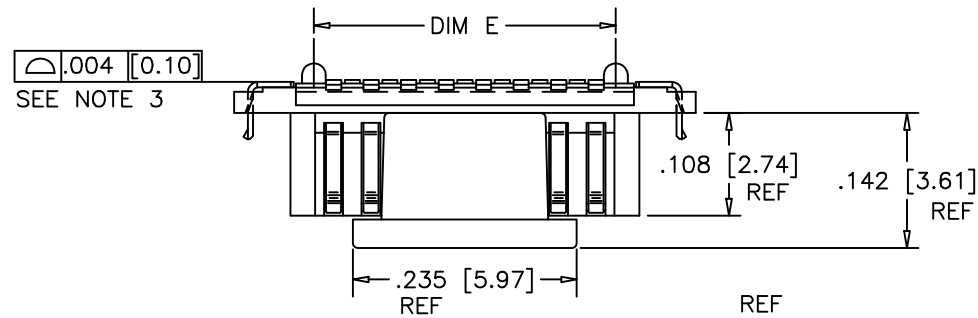

mat'l. code		surface ISO 1302 ✓		tolerance ISO 406 ISO 1101		projection ⊕		product family CONAN®		
ltr	ecn no	dr	date	tolerances unless otherwise specified						
c				angles	linear	linear		title CONAN® CONNECTOR ASSEMBLY		
				0°±2°	XXX±.01/XX±0.3	XXX±.005/XX±0.13	XXX±.0020/XX±0.05	INCH/MM		
								scale 5:1		
		dr	GM SUN	2013-01-14					dwg no	sheet 4 of 7 size
		enr	GM SUN	2013-01-14					10124017	A3
		chr	RICK BIAN	2013-01-14					type Product Customer Drawing	
		appd	RICK BIAN	2013-01-14						
sheet index	revision sheet									



Copyright FCI

PRODUCT NUMBER
SEE TABLE

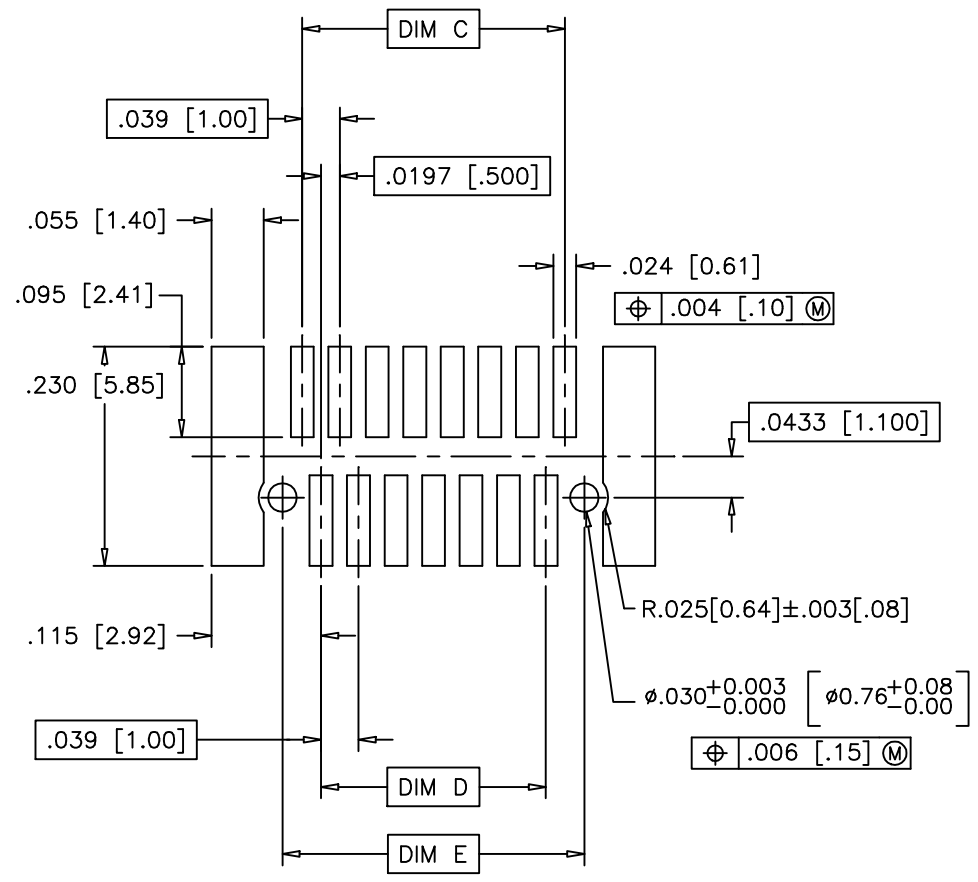

RECOMMENDED
PAD LAYOUT
FOR PLUG

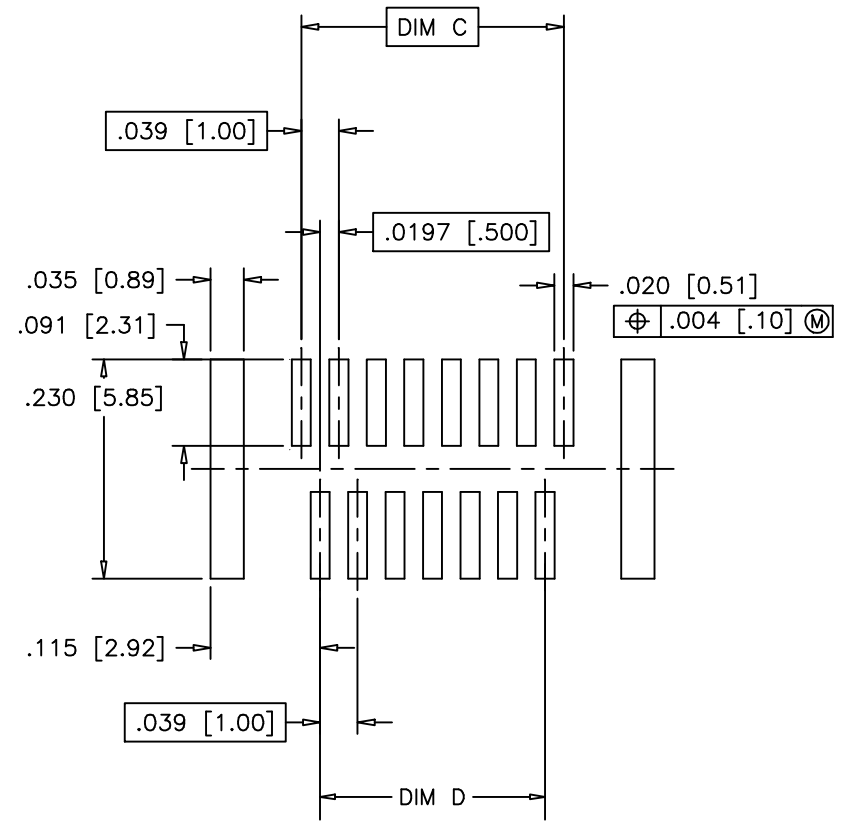

RECOMMENDED
STENCIL LAYOUT
FOR PLUG



Copyright FCI

mat'l. code		surface ISO 1302 ✓		tolerance ISO 406 ISO 1101		projection INCH/MM		product family CONAN®	
ltr		ecn no		dr		date		title	
c								CONAN® CONNECTOR ASSEMBLY	
		angles		linear		tolerances unless otherwise specified XXX±.01/XX±0.3 XXX±.005/XX±0.13 XXXX±.0020/XXX±0.05		scale 5:1	
		0°±2'						dwg no	
		dr		GM SUN		2013-01-14		sheet 5 of 7 size	
		enr		GM SUN		2013-01-14		10124017 A3	
		chr		RICK BIAN		2013-01-14		type	
		appd		RICK BIAN		2013-01-14		Product Customer Drawing	
sheet index		revision sheet							

PRODUCT NUMBER	POS	DIM "A"	DIM "C"	DIM "D"	DIM "E"
10124017-TCWXY09LF	9	.366 [9.30]	.157 [4.00]	.118 [3.00]	.1990 [5.055]
-TCWXY11LF	11	.406 [10.30]	.197 [5.00]	.157 [4.00]	.2380 [6.045]
-TCWXY15LF	15	.484 [12.30]	.276 [7.00]	.236 [6.00]	.3170 [8.052]
-TCWXY21LF	21	.602 [15.30]	.394 [10.00]	.354 [9.00]	.4350 [11.049]
-TCWXY25LF	25	.681 [17.30]	.472 [12.00]	.433 [11.00]	.5140 [13.056]
-TCWXY31LF	31	.800 [20.30]	.591 [15.00]	.551 [14.00]	.6320 [16.053]
-TCWXY41LF	41	.996 [25.30]	.787 [20.00]	.748 [19.00]	.8290 [21.057]
-TCWXY51LF	51	1.193 [30.30]	.984 [25.00]	.945 [24.00]	1.0260 [26.060]
-TCWXY69LF	69	1.547 [39.30]	1.339 [34.00]	1.299 [33.00]	1.3800 [35.052]

NOTES:

1. MATERIALS:

RECEPTACLE HOUSING - LCP, UL-94V-0. COLOR: NATURAL.

RECEPTACLE TERMINALS - COPPER ALLOY, PLATED WITH GOLD IN CONTACT AREA AND OTHER ALL AREA PLATING G/F WITH AN OVERALL 50µ"/1.27µ Ni UNDERPLATE.

PLUG HOUSING - LCP, UL-94V-0. COLOR: NATURAL.

PLUG TERMINALS - COPPER ALLOY, PLATED WITH GOLD IN CONTACT AREA AND OTHER ALL AREA PLATING G/F WITH AN OVERALL 50µ"/1.27µ Ni UNDERPLATE.

HOLD DOWN - COPPER ALLOY. PLATED WITH GOLD FLISH OVER NICKEL.

2. REFERENCE GS-12-0977 FOR PRODUCT PERFORMANCE AND ENVIRONMENTAL RESISTANCE DATA.

3. SEE TA-774 FOR FURTHER DESCRIPTION OF HOW THIS DIMENSION IS APPLIED.

4. RECOMMENDED SOLDER PASTE THICKNESS IS .006 TO .008 INCHES THICK.

5. THE TOE HEIGHT OF THE SOLDER TAIL SHALL BE MEASURED FROM THE LOWEST POINT OF THE .004 CO-PLANARITY GRAVITY PLANE. THIS MEASUREMENT IS NOT TO EXCEED A WINDOW OF .000 TO .007 INCHES.

6. THREE SLOTS MAY BE LOCATED AT EITHER END OF HOUSING.

7. THE HOUSING WILL WITHSTAND EXPOSURE TO 260°C PEAK TEMPERATURE FOR 30 SECONDS IN A CONVECTION INFRA RED OR VAPOR PHASE REFLOW OVEN. SEE APPLICATION/PROCEDURES IF THEY ARE AVAILABLE

8. PRODUCT WITH "LF" AT THE END MEETS EUROPEAN UNION DIRECTIVES AND OTHER COUNTRY REGULATION AS DESCRIBED IN GS-22-008.

FCIconnect.com

Copyright FCI

mat'l. code		surface ISO 1302	tolerance ISO 406 ISO 1101	projection 	product family CONAN®
ltr	ecn no	dr	date	tolerances unless otherwise specified	title CONAN® CONNECTOR ASSEMBLY
c				linear XXX±.01/XX±0.3 XXX±.005/XX±0.13 XXXX±.0020/XXX±0.05	INCH/MM scale 5:1
				dr	GM SUN 2013-01-14
				enr	GM SUN 2013-01-14
				chr	RICK BIAN 2013-01-14
				appd	RICK BIAN 2013-01-14
sheet index	revision sheet				dwg no 10124017 type Product Customer Drawing
					sheet 6 of 7 size A3

PRODUCT NUMBER
SEE TABLE

CONAN[®] ASSEMBLY PART NUMBER

10124017 - T C W X Y ZZ LF

LEAD FREE
SEE NOTE 8

TYPE	T
PLUG NO PEGS	0
PLUG WITH PEGS	1
RECEPTACLE NO PEGS	2
RECEPTACLE WITH PEGS	3

PICK AND PLACE CAP OR TAPE	C
WITHOUT CAP OR TAPE	0
WITH CAP	1
WITH TAPE (RECEPTACLE ONLY)	2

PACKAGING	W
TUBE	2
PRESSURE SEALED TAPE & REEL	3

Y	PLUG HEIGHT	RECEPTACLE HEIGHT	MATED HEIGHT	+0.10 -0.008 [+.25] [-.20]
1	.034 [.86]	.129 [3.28]	.163 [4.15]	
2	.048 [1.23]	SEE Y=1 FOR ALL RECEPTACLES	.177 [4.50]	
3	.068 [1.73]		.197 [5.00]	
4	.107 [2.72]		.236 [6.00]	
5	.1465 [3.721]		.276 [7.00]	

ZZ	NUMBER OF POSITIONS
09	9
11	11
15	15
21	21
25	25
31	31
41	41
51	51
69	69

X	PLATING
1	15u" Au ON CONTACT AREA, OTHER ALL AREA PLATING G/F.
2	30u" Au ON CONTACT AREA, OTHER ALL AREA PLATING G/F.

EXAMPLE: 10124017-3131125LF
IS A CONAN[®] RECEPTACLE ASSEMBLY,
HAVING PEGS AND WITH A PICK AND PLACE CAP.
IT IS .13 [3.2] HIGH AND 25 POSITIONS AND IS
PACKAGED IN PRESSURE SEALED TAPE, REEL AND LEAD FREE.

mat'l. code		surface ISO 1302	tolerance ISO 406 ISO 1101	projection 	product family CONAN [®]
ltr	ecn no	dr	date	tolerances unless otherwise specified	title CONAN [®] CONNECTOR ASSEMBLY
C				angles linear XX±.01/XX±0.3 XXX±.005/XXX±0.13 XXXX±.0020/XXX±0.05	
				0°±2'	INCH/MM scale 5:1
		dr	GM SUN	2013-01-14	 dwg no 10124017 sheet 7 of 7 size A3 type Product Customer Drawing
		enr	GM SUN	2013-01-14	
		chr	RICK BIAN	2013-01-14	
		appd	RICK BIAN	2013-01-14	
sheet index	revision sheet				