

REVISIONS					
P	LTR	DESCRIPTION	DATE	DWN	APVD
	B1	Redrawn to Creo	06MAR2017	JJH	JP

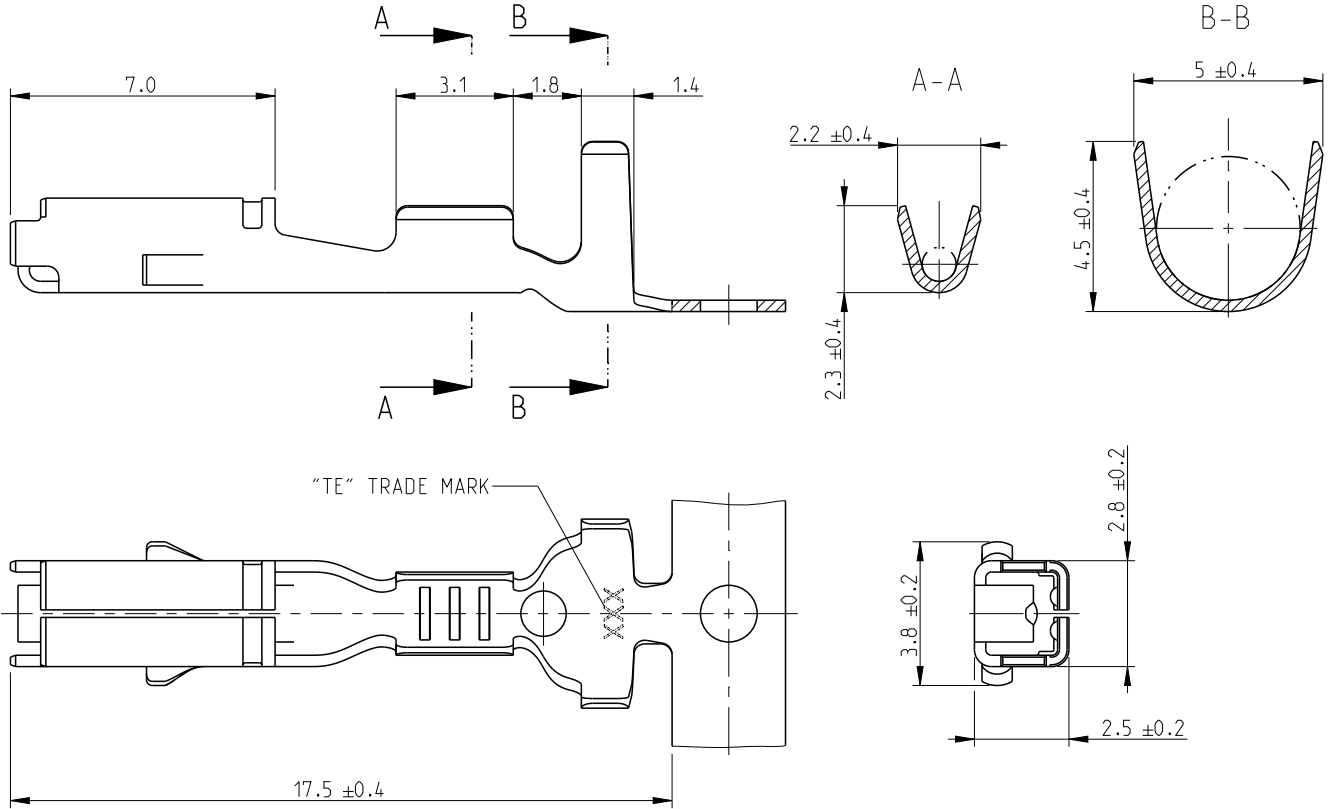

- DELIVERY STATE: WRAPPED UP ROLL WITH STEP BETWEEN TERMINALS = 11.9±0.2mm  
STATO DI FORNITURA: AVVOLTI SU BOBINA CON PASSO TRA TERMINALI DI = 11.9±0.2mm
- SUITABLE FOR SINGLE WIRE SEAL P/N 828904-1  
ADDETTO PER GOMMINO TE 828904-1

CUSTOMER DRAWING FOR INFORMATION ONLY  
DISEGNO PER CLIENTE SOLO PER RIFERIMENTO

B1

INS. DIA. RANGE (DIAM. ISOLANTE)	WIRE RANGE (RANGO FILO)
2	0.35 - 0.5mm <sup>2</sup>

PRE-TIN (PRE-STAGNATO)	BRASS (OTTONE)	282224-1
FINISH/COLOUR (FINITURE/COLORE)	MATERIAL (MATERIALE)	PART NUMBER

DIMENSIONS: mm	DWN D. CHIACCHIO 30AUG1994	MATERIAL	FINISH										
TOLERANCES UNLESS OTHERWISE SPECIFIED:	CHK G. VIGNOLI 30AUG1994	TE Connectivity											
<table border="1"> <tr> <td>0 PLC</td> <td>±</td> </tr> <tr> <td>1 PLC</td> <td>±</td> </tr> <tr> <td>2 PLC</td> <td>±</td> </tr> <tr> <td>3 PLC</td> <td>±</td> </tr> <tr> <td>4 PLC</td> <td>±</td> </tr> </table> ±0.3	0 PLC			±	1 PLC	±	2 PLC	±	3 PLC	±	4 PLC	±	APVD -
0 PLC	±												
1 PLC	±												
2 PLC	±												
3 PLC	±												
4 PLC	±												
<table border="1"> <tr> <td>ANGLES</td> <td>±2°</td> </tr> </table>	ANGLES	±2°	APPLICATION SPEC 114-20067	SIZE A 4	CAGE CODE -	DRAWING NO C=282224	RESTRICTED TO -						
ANGLES	±2°												
	WEIGHT -	CUSTOMER DRAWING		SCALE 5:1	SHEET 1 OF 1	REV B1							