

- 1 PARTS MUST COMPLY WITH AMP SOLDERABILITY SPEC 109-11-3.
- 2 CONTACT IS STAMPED FROM PRE-PLATED STOCK WHICH IS PLATED OVERALL WITH 0.00127 [.000050] NICKEL, THEN STRIPED WITH 0.00076 [.000030] GOLD IN CONTACT AREA INDICATED AND TIN-LEAD ON SOLDER TAIL END.
- 3 CIRCUIT IDENTIFICATION CHARACTERS ARE ADJACENT TO THE INDICATED CAVITIES, BUT LOCATION AND ORIENTATION MAY DIFFER FROM PRINT.
- 4 CONTACT IS PLATED OVERALL WITH 0.00127 [.000050] NICKEL, THEN 0.00076 [.000030] GOLD OVER CONTACT LENGTH INDICATED AND MATTE TIN ON SOLDER TAIL END.
- 5 SUPERSEDED BY 350762-5
- 6 DIMENSION SHOWN REPRESENT PRODUCT IN DRY CONDITION. ADDITIONAL 2% GROWTH DUE TO END USE LOCATION MOISTURE ABSORPTION MAY OCCUR AND SHOULD BE ACCOUNTED FOR.

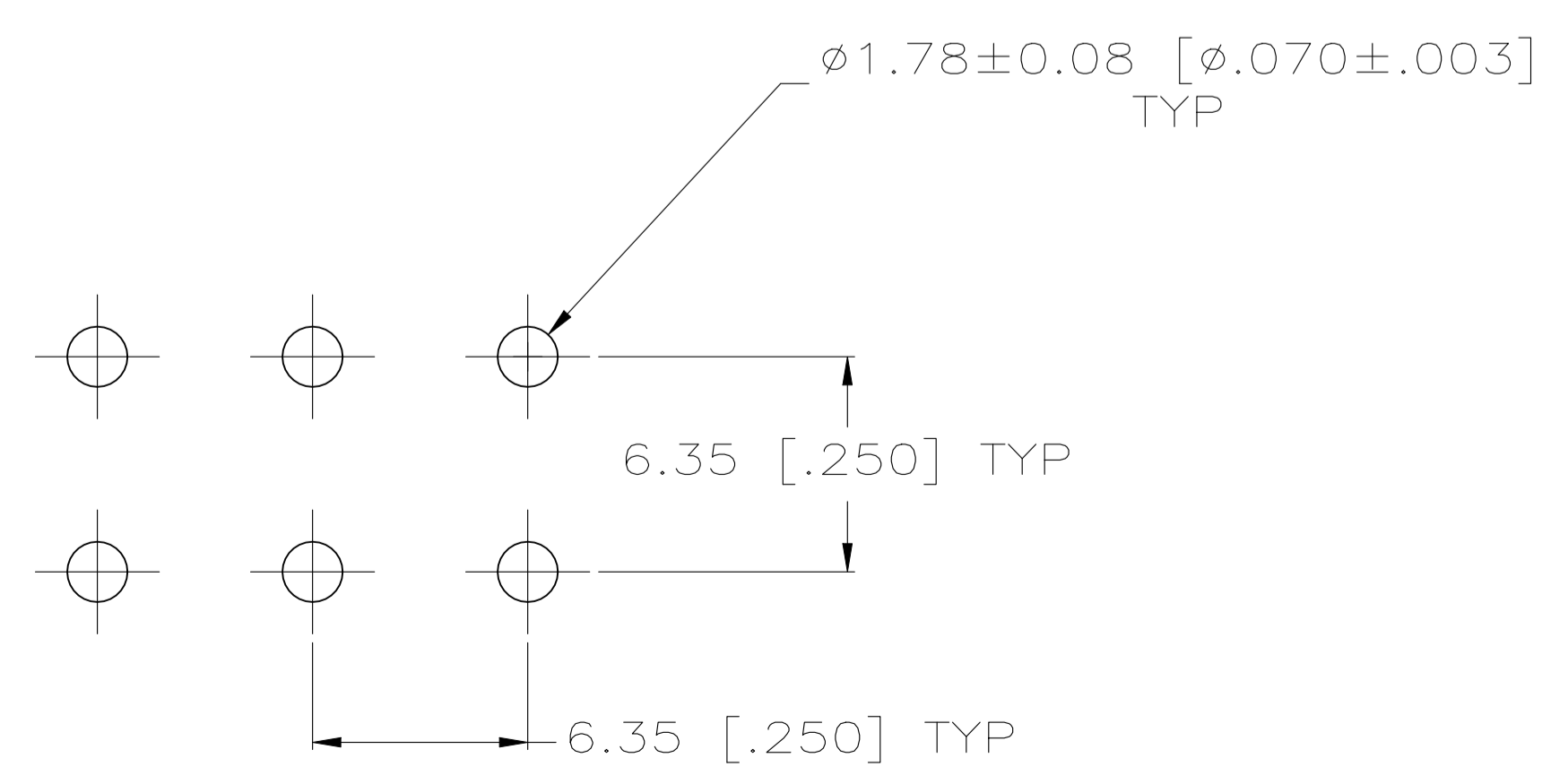

RECOMMENDED LAYOUT FOR 1.58 [.062] THICK PC BOARD

PH BRZ GOLD $\Delta 4$	NYLON, NATURAL	350762-5
PH BRZ TIN	NYLON, NATURAL	350762-4
$\Delta 5$ PH BRZ GOLD $\Delta 2$	NYLON, NATURAL	350762-3
CONTACT	HOUSING	PART NO

THIS DRAWING IS A CONTROLLED DOCUMENT.		DIN K. WHITAKER 11OCT2005		TE Connectivity	
DIMENSIONS: mm [INCHES]		CHK S. RIDGILL 11OCT2005			
TOLERANCES UNLESS OTHERWISE SPECIFIED:		APP'D S. RIDGILL 11OCT2005		NAME	
0 PLC ±		PRODUCT SPEC		6 CIRCUIT UNIVERSAL MATE-N-LOK (TM) P.C. BOARD SOCKET HEADER ASSEMBLY	
1 PLC ±		APPLICATION SPEC		SIZE CAGE CODE DRAWING NO	
2 PLC ±		WEIGHT		A1 00779 C=350762	
3 PLC ± 0.13 [.005]		CUSTOMER DRAWING		SCALE 5:1 SHEET 1 of 1 REV N2	
4 PLC ±					
ANGLES ±					
FINISH SEE TABLE					