

One Microamp Supply-Current, +3V to +5.5V, 250kbps, RS-232 Transmitters/Receivers

The Intersil ICL32XX devices are 3.0V to 5.5V powered RS-232 transmitters/receivers which meet EIA/TIA-232 and V.28/V.24 specifications, even at $V_{CC} = 3.0V$. Targeted applications are PDAs, Palmtops, and notebook and laptop computers where the low operational, and even lower standby, power consumption is critical. Efficient on-chip charge pumps, coupled with manual and automatic powerdown functions (except for the ICL3232), reduce the standby supply current to a $1\mu A$ trickle. Small footprint packaging, and the use of small, low value capacitors ensure board space savings as well. Data rates greater than 250kbps are guaranteed at worst case load conditions. This family is fully compatible with 3.3V only systems, mixed 3.3V and 5.0V systems, and 5.0V only systems.

The ICL324X are 3-driver, 5-receiver devices that provide a complete serial port suitable for laptop or notebook computers. Both devices also include noninverting always-active receivers for "wake-up" capability.

The **ICL3221, ICL3223 and ICL3243**, feature an **automatic powerdown** function which powers down the on-chip power-supply and driver circuits. This occurs when an attached peripheral device is shut off or the RS-232 cable is removed, conserving system power automatically without changes to the hardware or operating system. These devices power up again when a valid RS-232 voltage is applied to any receiver input.

Table 1 summarizes the features of the devices represented by this data sheet, while Application Note AN9863 summarizes the features of each device comprising the ICL32XX 3V family.

Features

- Pb-Free Plus Anneal Available as an Option (RoHS Compliant) (See Ordering Info)
- 15kV ESD Protected (Human Body Model)
- Drop in Replacements for MAX3221, MAX3222, MAX3223, MAX3232, MAX3241, MAX3243, SP3243
- ICL3221 is Low Power, Pin Compatible Upgrade for 5V MAX221
- ICL3222 is Low Power, Pin Compatible Upgrade for 5V MAX242, and SP312A
- ICL3232 is Low Power Upgrade for HIN232/ICL232 and Pin Compatible Competitor Devices
- RS-232 Compatible with $V_{CC} = 2.7V$
- Meets EIA/TIA-232 and V.28/V.24 Specifications at 3V
- Latch-Up Free
- On-Chip Voltage Converters Require Only Four External $0.1\mu F$ Capacitors
- Manual and Automatic Powerdown Features (Except ICL3232)
- Guaranteed Mouse Driveability (ICL324X Only)
- Receiver Hysteresis For Improved Noise Immunity
- Guaranteed Minimum Data Rate 250kbps
- Guaranteed Minimum Slew Rate $6V/\mu s$
- Wide Power Supply Range Single +3V to +5.5V
- Low Supply Current in Powerdown State $1\mu A$

Applications

- Any System Requiring RS-232 Communication Ports
 - Battery Powered, Hand-Held, and Portable Equipment
 - Laptop Computers, Notebooks, Palmtops
 - Modems, Printers and other Peripherals
 - Digital Cameras
 - Cellular/Mobile Phones

TABLE 1. SUMMARY OF FEATURES

PART NUMBER	NO. OF Tx.	NO. OF Rx.	NO. OF MONITOR Rx. (ROUTB)	DATA RATE (kbps)	Rx. ENABLE FUNCTION?	READY OUTPUT?	MANUAL POWER-DOWN?	AUTOMATIC POWERDOWN FUNCTION?
ICL3221	1	1	0	250	Yes	No	Yes	Yes
ICL3222	2	2	0	250	Yes	No	Yes	No
ICL3223	2	2	0	250	Yes	No	Yes	Yes
ICL3232	2	2	0	250	No	No	No	No
ICL3241	3	5	2	250	Yes	No	Yes	No
ICL3243	3	5	1	250	No	No	Yes	Yes

ICL3221, ICL3222, ICL3223, ICL3232, ICL3241, ICL3243

Ordering Information

PART NUMBER (NOTE 1)	PART MARKING	TEMP. RANGE (°C)	PACKAGE	PKG. DWG. #
ICL3221CA	ICL3221CA	0 to 70	16 Ld SSOP	M16.209
ICL3221CAZ (Note 2)	ICL3221CAZ	0 to 70	16 Ld SSOP (Pb-free)	M16.209
ICL3221CV	ICL3221CV	0 to 70	16 Ld TSSOP	M16.173
ICL3221CVZ (Note 2)	3221CVZ	0 to 70	16 Ld TSSOP (Pb-free)	M16.173
ICL3221IA	ICL3221IA	-40 to 85	16 Ld SSOP	M16.209
ICL3221IAZ (Note 2)	ICL3221IAZ	-40 to 85	16 Ld SSOP (Pb-free)	M16.209
ICL3222CA	ICL3222CA	0 to 70	20 Ld SSOP	M20.209
ICL3222CAZ (Note 2)	ICL3222CAZ	0 to 70	20 Ld SSOP (Pb-free)	M20.209
ICL3222CB	ICL3222CB	0 to 70	18 Ld SOIC	M18.3
ICL3222CBZ (Note 2)	3222CBZ	0 to 70	18 Ld SOIC (Pb-free)	M18.3
ICL3222CP	ICL3222CP	0 to 70	18 Ld PDIP	E18.3
ICL3222CPZ (Note 2)	ICL3222CPZ	0 to 70	18 Ld PDIP* (Pb-free)	E18.3
ICL3222CV	ICL3222CV	0 to 70	20 Ld TSSOP	M20.173
ICL3222CVZ (Note 2)	ICL3222CVZ	0 to 70	20 Ld TSSOP (Pb-free)	M20.173
ICL3222IA	ICL3222IA	-40 to 85	20 Ld SSOP	M20.209
ICL3222IAZ (Note 2)	ICL3222IAZ	-40 to 85	20 Ld SSOP (Pb-free)	M20.209
ICL3222IB	ICL3222IB	-40 to 85	18 Ld SOIC	M18.3
ICL3222IV	ICL3222IV	-40 to 85	20 Ld TSSOP	M20.173
ICL3222IVZ (Note 2)	ICL3222IVZ	-40 to 85	20 Ld TSSOP (Pb-free)	M20.173
ICL3223CA	ICL3223CA	0 to 70	20 Ld SSOP	M20.209
ICL3223CAZ (Note 2)	ICL3223CAZ	0 to 70	20 Ld SSOP (Pb-free)	M20.209
ICL3223CP	ICL3223CP	0 to 70	20 Ld PDIP	E20.3
ICL3223CPZ (Note 2)	ICL3223CPZ	0 to 70	20 Ld PDIP* (Pb-free)	E20.3
ICL3223CV	ICL3223CV	0 to 70	20 Ld TSSOP	M20.173
ICL3223IA	ICL3223IA	-40 to 85	20 Ld SSOP	M20.209
ICL3223IAZ (Note 2)	ICL3223IAZ	-40 to 85	20 Ld SSOP (Pb-free)	M20.209
ICL3223IV	ICL3223IV	-40 to 85	20 Ld TSSOP	M20.173
ICL3223IVZ (Note 2)	ICL3223IVZ	-40 to 85	20 Ld TSSOP (Pb-free)	M20.173
ICL3232CA	ICL3232CA	0 to 70	16 Ld SSOP	M16.209
ICL3232CAZ (Note 2)	3232CAZ	0 to 70	16 Ld SSOP (Pb-free)	M16.209
ICL3232CB	ICL3232CB	0 to 70	16 Ld SOIC	M16.3
ICL3232CBZ (Note 2)	3232CBZ	0 to 70	16 Ld SOIC (Pb-free)	M16.3
ICL3232CBN	3232CBN	0 to 70	16 Ld SOIC (N)	M16.15
ICL3232CBNZ (Note 2)	3232CBNZ	0 to 70	16 Ld SOIC (N) (Pb-free)	M16.15
ICL3232CP	ICL3232CP	0 to 70	16 Ld PDIP	E16.3
ICL3232CPZ (Note 2)	ICL3232CPZ	0 to 70	16 Ld PDIP* (Pb-free)	E16.3
ICL3232CV	ICL3232CV	0 to 70	16 Ld TSSOP	M16.173

ICL3221, ICL3222, ICL3223, ICL3232, ICL3241, ICL3243

Ordering Information (Continued)

PART NUMBER (NOTE 1)	PART MARKING	TEMP. RANGE (°C)	PACKAGE	PKG. DWG. #
ICL3232CVZ (Note 2)	3232CVZ	0 to 70	16 Ld TSSOP (Pb-free)	M16.173
ICL3232IA	ICL3232IA	-40 to 85	16 Ld SSOP	M16.209
ICL3232IAZ (Note 2)	3232IAZ	-40 to 85	16 Ld SSOP (Pb-free)	M16.209
ICL3232IB	ICL3232IB	-40 to 85	16 Ld SOIC	M16.3
ICL3232IBZ (Note 2)	3232IBZ	-40 to 85	16 Ld SOIC (Pb-free)	M16.3
ICL3232IBN	3232IBN	-40 to 85	16 Ld SOIC (N)	M16.15
ICL3232IBNZ (Note 2)	3232IBNZ	-40 to 85	16 Ld SOIC (N) (Pb-free)	M16.15
ICL3232IV	ICL3232IV	-40 to 85	16 Ld TSSOP	M16.173
ICL3232IVZ (Note 2)	3232IVZ	-40 to 85	16 Ld TSSOP (Pb-free)	M16.173
ICL3241CA	ICL3241CA	0 to 70	28 Ld SSOP	M28.209
ICL3241CAZ (Note 2)	ICL3241CAZ	0 to 70	28 Ld SSOP (Pb-free)	M28.209
ICL3241CB	ICL3241CB	0 to 70	28 Ld SOIC	M28.3
ICL3241CBZ (Note 2)	ICL3241CBZ	0 to 70	28 Ld SOIC (Pb-free)	M28.3
ICL3241CV	ICL3241CV	0 to 70	28 Ld TSSOP	M28.173
ICL3241CVZ (Note 2)	ICL3241CVZ	0 to 70	28 Ld TSSOP (Pb-free)	M28.173
ICL3241IA	ICL3241IA	-40 to 85	28 Ld SSOP	M28.209
ICL3241IAZ (Note 2)	ICL3241IAZ	-40 to 85	28 Ld SSOP (Pb-free)	M28.209
ICL3241IB	ICL3241IB	-40 to 85	28 Ld SOIC	M28.3
ICL3241IBZ (Note 2)	ICL3241IBZ	-40 to 85	28 Ld SOIC (Pb-free)	M28.3
ICL3241IV	ICL3241IV	-40 to 85	28 Ld TSSOP	M28.173
ICL3241IVZ (Note 2)	ICL3241IVZ	-40 to 85	28 Ld TSSOP (Pb-free)	M28.173
ICL3243CA	ICL3243CA	0 to 70	28 Ld SSOP	M28.209
ICL3243CAZ (Note 2)	ICL3243CAZ	0 to 70	28 Ld SSOP (Pb-free)	M28.209
ICL3243CB	ICL3243CB	0 to 70	28 Ld SOIC	M28.3
ICL3243CBZ (Note 2)	ICL3243CBZ	0 to 70	28 Ld SOIC (Pb-free)	M28.3
ICL3243CV	ICL3243CV	0 to 70	28 Ld TSSOP	M28.173
ICL3243CVZ (Note 2)	ICL3243CVZ	0 to 70	28 Ld TSSOP (Pb-free)	M28.173
ICL3243IA	ICL3243IA	-40 to 85	28 Ld SSOP	M28.209
ICL3243IAZ (Note 2)	ICL3243IAZ	-40 to 85	28 Ld SSOP (Pb-free)	M28.209

*Pb-free PDIPs can be used for through hole wave solder processing only. They are not intended for use in Reflow solder processing applications.

NOTES:

1. Most surface mount devices are available on tape and reel; add "-T" to suffix.
2. Intersil Pb-free plus anneal products employ special Pb-free material sets; molding compounds/die attach materials and 100% matte tin plate termination finish, which are RoHS compliant and compatible with both SnPb and Pb-free soldering operations. Intersil Pb-free products are MSL classified at Pb-free peak reflow temperatures that meet or exceed the Pb-free requirements of IPC/JEDEC J STD-020.

Pinouts

ICL3221 (SSOP, TSSOP)
TOP VIEW

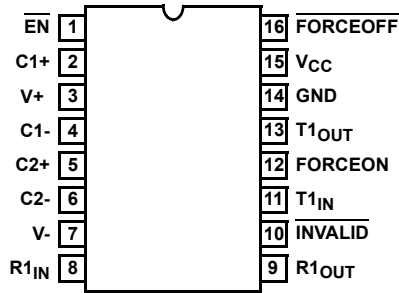

ICL3222 (PDIP, SOIC)
TOP VIEW

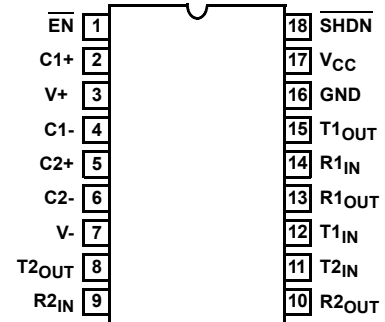

ICL3222 (SSOP, TSSOP)
TOP VIEW

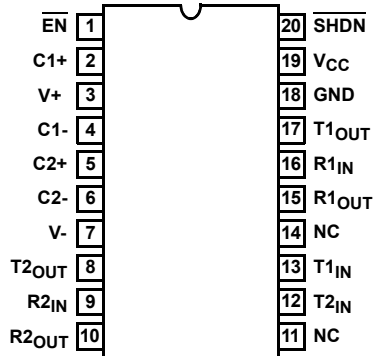

ICL3223 (PDIP, SSOP, TSSOP)
TOP VIEW

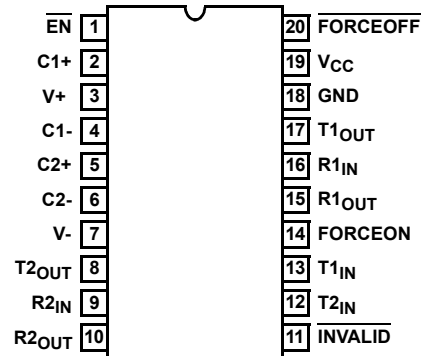

ICL3232 (PDIP, SOIC, SSOP, TSSOP)
TOP VIEW

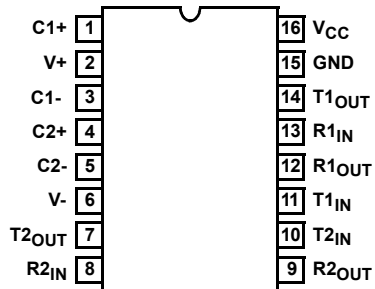

ICL3241 (SOIC, SSOP, TSSOP)
TOP VIEW

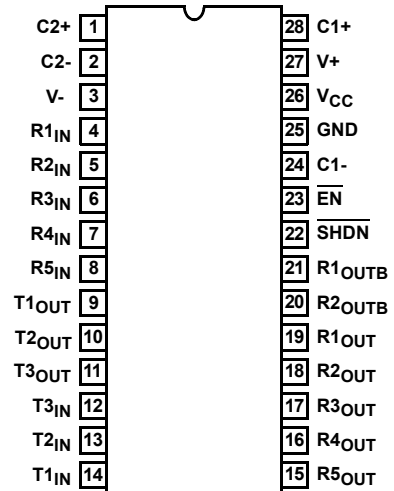

Pinouts (Continued)

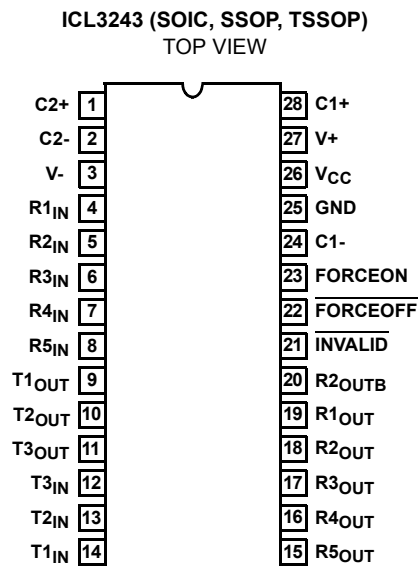

Pin Descriptions

PIN	FUNCTION
V _{CC}	System power supply input (3.0V to 5.5V).
V+	Internally generated positive transmitter supply (+5.5V).
V-	Internally generated negative transmitter supply (-5.5V).
GND	Ground connection.
C1+	External capacitor (voltage doubler) is connected to this lead.
C1-	External capacitor (voltage doubler) is connected to this lead.
C2+	External capacitor (voltage inverter) is connected to this lead.
C2-	External capacitor (voltage inverter) is connected to this lead.
T _{IN}	TTL/CMOS compatible transmitter Inputs.
T _{OUT}	RS-232 level (nominally ±5.5V) transmitter outputs.
R _{IN}	RS-232 compatible receiver inputs.
R _{OUT}	TTL/CMOS level receiver outputs.
R _{OUTB}	TTL/CMOS level, noninverting, always enabled receiver outputs.
$\overline{\text{INVALID}}$	Active low output that indicates if no valid RS-232 levels are present on any receiver input.
$\overline{\text{EN}}$	Active low receiver enable control; doesn't disable R _{OUTB} outputs.
$\overline{\text{SHDN}}$	Active low input to shut down transmitters and on-board power supply, to place device in low power mode.
$\overline{\text{FORCEOFF}}$	Active low to shut down transmitters and on-chip power supply. This overrides any automatic circuitry and FORCEON (See Table 2).
FORCEON	Active high input to override automatic powerdown circuitry thereby keeping transmitters active. ($\overline{\text{FORCEOFF}}$ must be high).

Typical Operating Circuits

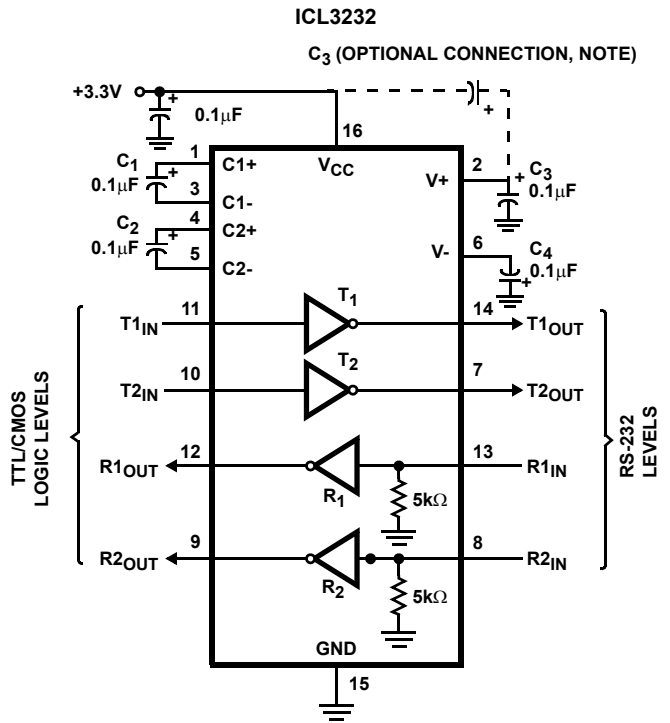
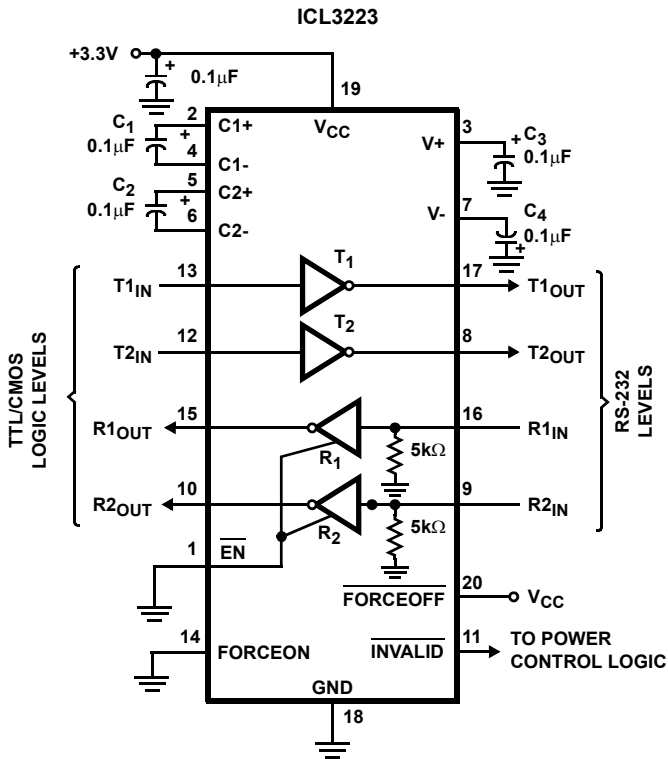
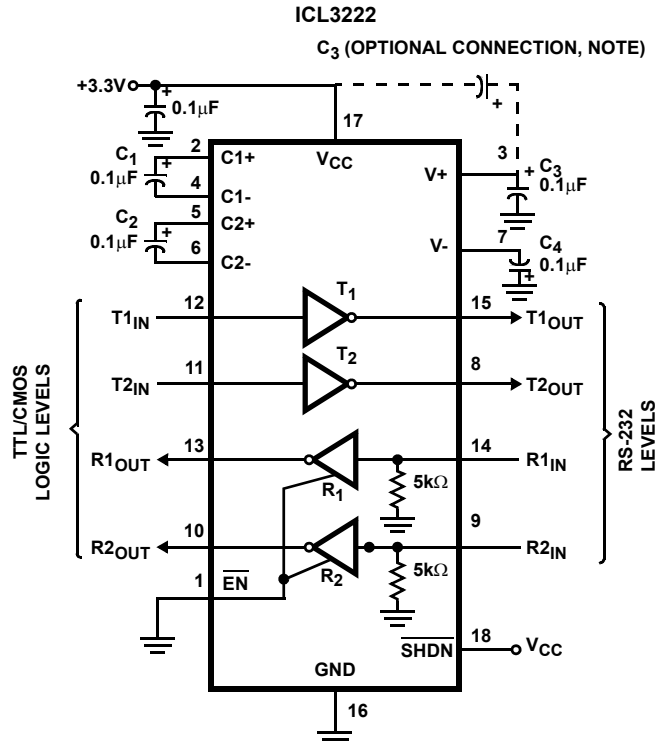
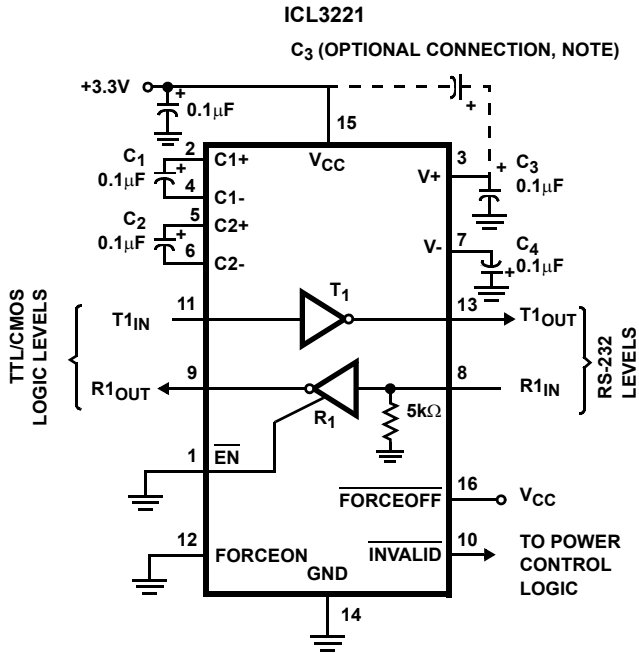

Typical Operating Circuits (Continued)

ICL3241

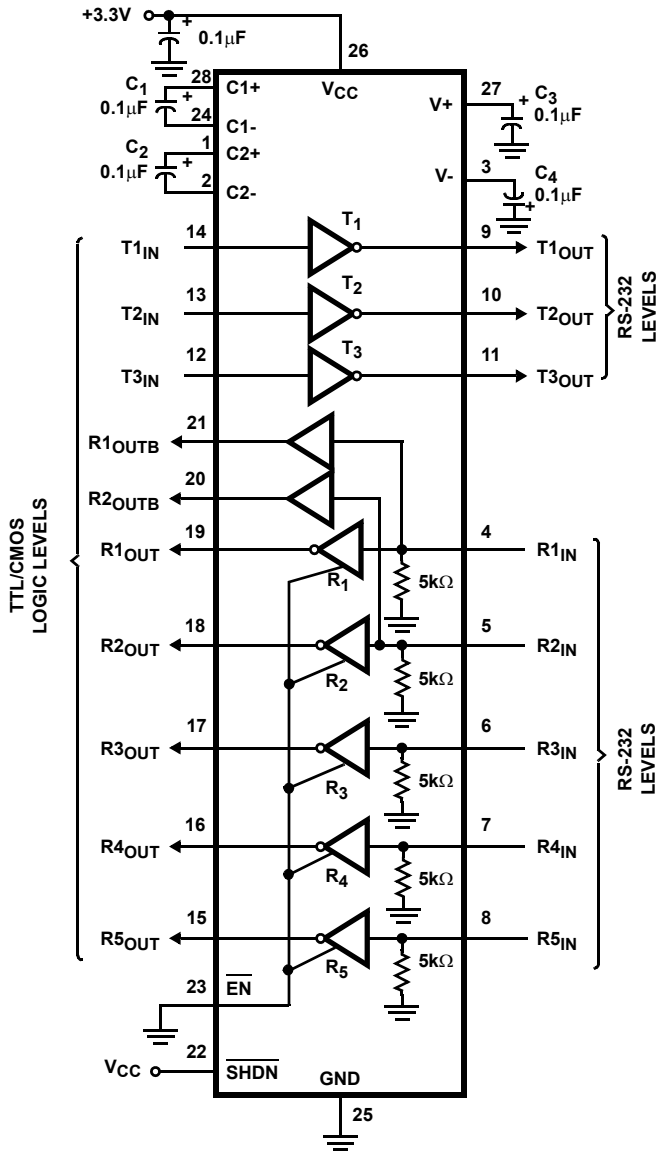

ICL3243

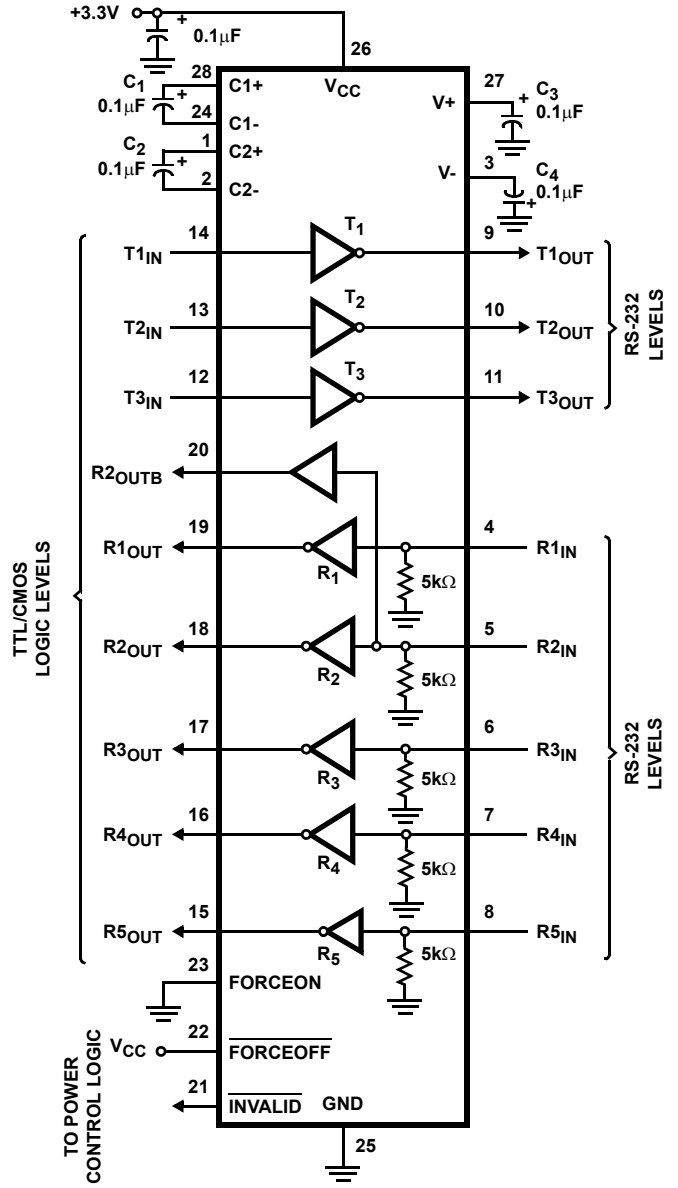

ICL3221, ICL3222, ICL3223, ICL3232, ICL3241, ICL3243

Absolute Maximum Ratings

V _{CC} to Ground	-0.3V to 6V
V ₊ to Ground	-0.3V to 7V
V ₋ to Ground	+0.3V to -7V
V ₊ to V ₋	14V
Input Voltages	
T _{IN} , FORCEOFF, FORCEON, EN, SHDN	-0.3V to 6V
R _{IN}	±25V
Output Voltages	
T _{OUT}	±13.2V
R _{OUT} , INVALID	-0.3V to V _{CC} +0.3V
Short Circuit Duration	
T _{OUT}	Continuous
ESD Rating	See Specification Table

Operating Conditions

Temperature Range	
ICL32XXCX	0°C to 70°C
ICL32XXIX	-40°C to 85°C

Thermal Information

Thermal Resistance (Typical, Note 3)	θ _{JA} (°C/W)
16 Ld PDIP Package*	90
18 Ld PDIP Package*	80
20 Ld PDIP Package*	77
16 Ld Wide SOIC Package	100
16 Ld Narrow SOIC Package	115
18 Ld SOIC Package	75
28 Ld SOIC Package	75
16 Ld SSOP Package	135
20 Ld SSOP Package	122
16 Ld TSSOP Package	145
20 Ld TSSOP Package	140
28 Ld SSOP and TSSOP Packages	100
Maximum Junction Temperature (Plastic Package)	150°C
Maximum Storage Temperature Range	-65°C to 150°C
Maximum Lead Temperature (Soldering 10s) (SOIC, SSOP, TSSOP - Lead Tips Only)	300°C

*Pb-free PDIPs can be used for through hole wave solder processing only. They are not intended for use in Reflow solder processing applications.

CAUTION: Stresses above those listed in "Absolute Maximum Ratings" may cause permanent damage to the device. This is a stress only rating and operation of the device at these or any other conditions above those indicated in the operational sections of this specification is not implied.

NOTE:

- θ_{JA} is measured with the component mounted on a low effective thermal conductivity test board in free air. See Tech Brief TB379 for details.

Electrical Specifications

Test Conditions: V_{CC} = 3V to 5.5V, C1 - C4 = 0.1μF; Unless Otherwise Specified.
Typicals are at TA = 25°C

PARAMETER	TEST CONDITIONS	TEMP (°C)	MIN	TYP	MAX	UNITS	
DC CHARACTERISTICS							
Supply Current, Automatic Powerdown	All R _{IN} Open, FORCEON = GND, FORCEOFF = V _{CC} (ICL3221, ICL3223, ICL3243 Only)	25	-	1.0	10	μA	
Supply Current, Powerdown	FORCEOFF = SHDN = GND (Except ICL3232)	25	-	1.0	10	μA	
Supply Current, Automatic Powerdown Disabled	All Outputs Unloaded, FORCEON = FORCEOFF = SHDN = V _{CC}	V _{CC} = 3.15V, ICL3221-32	25	-	0.3	1.0	mA
		V _{CC} = 3.0V, ICL3241-43	25	-	0.3	1.0	mA
LOGIC AND TRANSMITTER INPUTS AND RECEIVER OUTPUTS							
Input Logic Threshold Low	T _{IN} , FORCEON, FORCEOFF, EN, SHDN	Full	-	-	0.8	V	
Input Logic Threshold High	T _{IN} , FORCEON, FORCEOFF, EN, SHDN	V _{CC} = 3.3V	Full	2.0	-	-	V
		V _{CC} = 5.0V	Full	2.4	-	-	V
Input Leakage Current	T _{IN} , FORCEON, FORCEOFF, EN, SHDN	Full	-	±0.01	±1.0	μA	
Output Leakage Current (Except ICL3232)	FORCEOFF = GND or EN = V _{CC}	Full	-	±0.05	±10	μA	
Output Voltage Low	I _{OUT} = 1.6mA	Full	-	-	0.4	V	
Output Voltage High	I _{OUT} = -1.0mA	Full	V _{CC} -0.6	V _{CC} -0.1	-	V	
AUTOMATIC POWERDOWN (ICL3221, ICL3223, ICL3243 Only, FORCEON = GND, FORCEOFF = V_{CC})							
Receiver Input Thresholds to Enable Transmitters	ICL32XX Powers Up (See Figure 6)	Full	-2.7	-	2.7	V	
Receiver Input Thresholds to Disable Transmitters	ICL32XX Powers Down (See Figure 6)	Full	-0.3	-	0.3	V	
INVALID Output Voltage Low	I _{OUT} = 1.6mA	Full	-	-	0.4	V	
INVALID Output Voltage High	I _{OUT} = -1.0mA	Full	V _{CC} -0.6	-	-	V	

ICL3221, ICL3222, ICL3223, ICL3232, ICL3241, ICL3243

Electrical Specifications Test Conditions: VCC = 3V to 5.5V, C1 - C4 = 0.1μF; Unless Otherwise Specified.
Typicals are at TA = 25°C (Continued)

PARAMETER	TEST CONDITIONS	TEMP (°C)	MIN	TYP	MAX	UNITS	
Receiver Threshold to Transmitters Enabled Delay (t _{WU})		25	-	100	-	μs	
Receiver Positive or Negative Threshold to INVALID High Delay (t _{INVH})		25	-	1	-	μs	
Receiver Positive or Negative Threshold to INVALID Low Delay (t _{INVL})		25	-	30	-	μs	
RECEIVER INPUTS							
Input Voltage Range		Full	-25	-	25	V	
Input Threshold Low	V _{CC} = 3.3V	25	0.6	1.2	-	V	
	V _{CC} = 5.0V	25	0.8	1.5	-	V	
Input Threshold High	V _{CC} = 3.3V	25	-	1.5	2.4	V	
	V _{CC} = 5.0V	25	-	1.8	2.4	V	
Input Hysteresis		25	-	0.3	-	V	
Input Resistance		25	3	5	7	kΩ	
TRANSMITTER OUTPUTS							
Output Voltage Swing	All Transmitter Outputs Loaded with 3kΩ to Ground	Full	±5.0	±5.4	-	V	
Output Resistance	V _{CC} = V+ = V- = 0V, Transmitter Output = ±2V	Full	300	10M	-	Ω	
Output Short-Circuit Current		Full	-	±35	±60	mA	
Output Leakage Current	V _{OUT} = ±12V, V _{CC} = 0V or 3V to 5.5V Automatic Powerdown or FORCEOFF = SHDN = GND	Full	-	-	±25	μA	
MOUSE DRIVEABILITY (ICL324X Only)							
Transmitter Output Voltage (See Figure 9)	T1 _{IN} = T2 _{IN} = GND, T3 _{IN} = V _{CC} , T3 _{OUT} Loaded with 3kΩ to GND, T1 _{OUT} and T2 _{OUT} Loaded with 2.5mA Each	Full	±5	-	-	V	
TIMING CHARACTERISTICS							
Maximum Data Rate	R _L = 3kΩ, C _L = 1000pF, One Transmitter Switching	Full	250	500	-	kbps	
Receiver Propagation Delay	Receiver Input to Receiver Output, C _L = 150pF	t _{PHL}	25	-	0.3	-	μs
		t _{PLH}	25	-	0.3	-	μs
Receiver Output Enable Time	Normal Operation (Except ICL3232)	25	-	200	-	ns	
Receiver Output Disable Time	Normal Operation (Except ICL3232)	25	-	200	-	ns	
Transmitter Skew	t _{PHL} - t _{PLH}	Full	-	200	1000	ns	
Receiver Skew	t _{PHL} - t _{PLH}	Full	-	100	500	ns	
Transition Region Slew Rate	V _{CC} = 3.3V, R _L = 3kΩ to 7kΩ, Measured From 3V to -3V or -3V to 3V	C _L = 200pF to 2500pF	25	4	8.0	30	V/μs
		C _L = 200pF to 1000pF	25	6	-	30	V/μs
ESD PERFORMANCE							
RS-232 Pins (T _{OUT} , R _{IN})	Human Body Model	ICL3221 - ICL3243	25	-	±15	-	kV
	IEC61000-4-2 Contact Discharge	ICL3221 - ICL3243	25	-	±8	-	kV
	IEC61000-4-2 Air Gap Discharge	ICL3221 - ICL3232	25	-	±8	-	kV
		ICL3241 - ICL3243	25	-	±6	-	kV
All Other Pins	Human Body Model	ICL3221 - ICL3243	25	-	±2	-	kV

Detailed Description

ICL32XX interface ICs operate from a single +3V to +5.5V supply, guarantee a 250kbps minimum data rate, require only four small external 0.1 μ F capacitors, feature low power consumption, and meet all EIA RS-232C and V.28 specifications. The circuit is divided into three sections: charge pump, transmitters and receivers.

Charge-Pump

Intersil's new ICL32XX family utilizes regulated on-chip dual charge pumps as voltage doublers, and voltage inverters to generate $\pm 5.5V$ transmitter supplies from a V_{CC} supply as low as 3.0V. This allows these devices to maintain RS-232 compliant output levels over the $\pm 10\%$ tolerance range of 3.3V powered systems. The efficient on-chip power supplies require only four small, external 0.1 μ F capacitors for the voltage doubler and inverter functions at $V_{CC} = 3.3V$. See the *Capacitor Selection* section, and Table 3 for capacitor recommendations for other operating conditions. The charge pumps operate discontinuously (i.e., they turn off as soon as the V+ and V- supplies are pumped up to the nominal values), resulting in significant power savings.

Transmitters

The transmitters are proprietary, low dropout, inverting drivers that translate TTL/CMOS inputs to EIA/TIA-232 output levels. Coupled with the on-chip $\pm 5.5V$ supplies, these transmitters deliver true RS-232 levels over a wide range of single supply system voltages.

Except for the ICL3232, all transmitter outputs disable and assume a high impedance state when the device enters the powerdown mode (See Table 2). These outputs may be driven to $\pm 12V$ when disabled.

All devices guarantee a 250kbps data rate for full load conditions (3k Ω and 1000pF), $V_{CC} \geq 3.0V$, with one transmitter operating at full speed. Under more typical conditions of $V_{CC} \geq 3.3V$, $R_L = 3k\Omega$, and $C_L = 250pF$, one transmitter easily operates at 900kbps.

Transmitter inputs float if left unconnected, and may cause I_{CC} increases. Connect unused inputs to GND for the best performance.

Receivers

All the ICL32XX devices contain standard inverting receivers that three-state (except for the ICL3232) via the EN or FORCEOFF control lines. Additionally, the two ICL324X products include noninverting (monitor) receivers (denoted by the R_{OUTB} label) that are always active, regardless of the state of any control lines. All the receivers convert RS-232 signals to CMOS output levels and accept inputs up to $\pm 25V$ while presenting the required 3k Ω to 7k Ω input impedance (See Figure 1) even if the power is off ($V_{CC} = 0V$). The receivers' Schmitt trigger input stage uses hysteresis to increase noise immunity and decrease errors due to slow input signal transitions.

The ICL3221/22/23/41 inverting receivers disable only when EN is driven high. ICL3243 receivers disable during forced (manual) powerdown, but not during automatic powerdown (See Table 2).

ICL324X monitor receivers remain active even during manual powerdown and forced receiver disable, making them extremely useful for Ring Indicator monitoring. Standard receivers driving powered down peripherals must be disabled to prevent current flow through the peripheral's protection diodes (See Figures 2 and 3). This renders them useless for wake up functions, but the corresponding monitor receiver can be dedicated to this task as shown in Figure 3.

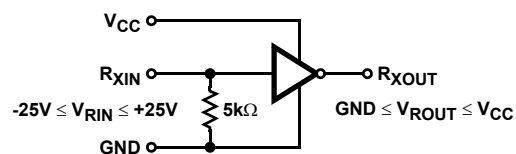

FIGURE 1. INVERTING RECEIVER CONNECTIONS

Low Power Operation

These 3V devices require a nominal supply current of 0.3mA, even at $V_{CC} = 5.5V$, during normal operation (not in powerdown mode). This is considerably less than the 5mA to 11mA current required by comparable 5V RS-232 devices, allowing users to reduce system power simply by switching to this new family.

Pin Compatible Replacements For 5V Devices

The ICL3221/22/32 are pin compatible with existing 5V RS-232 transceivers - see the *Features* section on the front page for details.

This pin compatibility coupled with the low I_{CC} and wide operating supply range, make the ICL32XX potential lower power, higher performance drop-in replacements for existing 5V applications. As long as the $\pm 5V$ RS-232 output swings are acceptable, and transmitter input pull-up resistors aren't required, the ICL32XX should work in most 5V applications.

When replacing a device in an existing 5V application, it is acceptable to terminate C_3 to V_{CC} as shown on the *Typical Operating Circuit*. Nevertheless, terminate C_3 to GND if possible, as slightly better performance results from this configuration.

Powerdown Functionality (Except ICL3232)

The already low current requirement drops significantly when the device enters powerdown mode. In powerdown, supply current drops to 1 μ A, because the on-chip charge pump turns off (V_+ collapses to V_{CC} , V_- collapses to GND), and the transmitter outputs three-state. Inverting receiver outputs may or may not disable in powerdown; refer to Table 2 for details. This micro-power mode makes these devices ideal for battery powered and portable applications.

Software Controlled (Manual) Powerdown

Most devices in the ICL32XX family provide pins that allow the user to force the IC into the low power, standby state.

On the ICL3222 and ICL3241, the powerdown control is via a simple shutdown (SHDN) pin. Driving this pin high enables normal operation, while driving it low forces the IC into its powerdown state. Connect SHDN to V_{CC} if the powerdown function isn't needed. Note that all the receiver outputs remain enabled during shutdown (See Table 2). For the lowest power consumption during powerdown, the receivers should also be disabled by driving the $\overline{\text{EN}}$ input high (See next section, and Figures 2 and 3).

The ICL3221, ICL3223, and ICL3243 utilize a two pin approach where the FORCEON and $\overline{\text{FORCEOFF}}$ inputs determine the IC's mode. For always enabled operation, FORCEON and $\overline{\text{FORCEOFF}}$ are both strapped high. To switch between active and powerdown modes, under logic or software control, only the $\overline{\text{FORCEOFF}}$ input need be driven. The FORCEON state isn't critical, as $\overline{\text{FORCEOFF}}$ dominates over FORCEON. Nevertheless, if strictly manual control over powerdown is desired, the user must strap FORCEON high to disable the automatic powerdown circuitry. ICL3243 inverting (standard) receiver outputs also disable when the device is in manual powerdown, thereby eliminating the possible current path through a shutdown peripheral's input protection diode (See Figures 2 and 3).

TABLE 2. POWERDOWN AND ENABLE LOGIC TRUTH TABLE

RS-232 SIGNAL PRESENT AT RECEIVER INPUT?	$\overline{\text{FORCEOFF}}$ OR SHDN INPUT	FORCEON INPUT	$\overline{\text{EN}}$ INPUT	TRANSMITTER OUTPUTS	RECEIVER OUTPUTS	(NOTE 4) R _{OUTB} OUTPUTS	$\overline{\text{INVALID}}$ OUTPUT	MODE OF OPERATION
ICL3222, ICL3241								
N.A.	L	N.A.	L	High-Z	Active	Active	N.A.	Manual Powerdown
N.A.	L	N.A.	H	High-Z	High-Z	Active	N.A.	Manual Powerdown w/Rcvr. Disabled
N.A.	H	N.A.	L	Active	Active	Active	N.A.	Normal Operation
N.A.	H	N.A.	H	Active	High-Z	Active	N.A.	Normal Operation w/Rcvr. Disabled
ICL3221, ICL3223								
No	H	H	L	Active	Active	N.A.	L	Normal Operation (Auto Powerdown Disabled)
No	H	H	H	Active	High-Z	N.A.	L	
Yes	H	L	L	Active	Active	N.A.	H	Normal Operation (Auto Powerdown Enabled)
Yes	H	L	H	Active	High-Z	N.A.	H	
No	H	L	L	High-Z	Active	N.A.	L	Powerdown Due to Auto Powerdown Logic
No	H	L	H	High-Z	High-Z	N.A.	L	
Yes	L	X	L	High-Z	Active	N.A.	H	Manual Powerdown
Yes	L	X	H	High-Z	High-Z	N.A.	H	Manual Powerdown w/Rcvr. Disabled
No	L	X	L	High-Z	Active	N.A.	L	Manual Powerdown
No	L	X	H	High-Z	High-Z	N.A.	L	Manual Powerdown w/Rcvr. Disabled
ICL3243								
No	H	H	N.A.	Active	Active	Active	L	Normal Operation (Auto Powerdown Disabled)
Yes	H	L	N.A.	Active	Active	Active	H	Normal Operation (Auto Powerdown Enabled)
No	H	L	N.A.	High-Z	Active	Active	L	Powerdown Due to Auto Powerdown Logic
Yes	L	X	N.A.	High-Z	High-Z	Active	H	Manual Powerdown
No	L	X	N.A.	High-Z	High-Z	Active	L	Manual Powerdown

NOTE:

- 4. Applies only to the ICL3241 and ICL3243.

The $\overline{\text{INVALID}}$ output always indicates whether or not a valid RS-232 signal is present at any of the receiver inputs (See Table 2), giving the user an easy way to determine when the interface block should power down. In the case of a disconnected interface cable where all the receiver inputs are floating (but pulled to GND by the internal receiver pull down resistors), the $\overline{\text{INVALID}}$ logic detects the invalid levels and drives the output low. The power management logic then uses this indicator to power down the interface block. Reconnecting the cable restores valid levels at the receiver inputs, $\overline{\text{INVALID}}$ switches high, and the power management logic wakes up the interface block. $\overline{\text{INVALID}}$ can also be used to indicate the DTR or RING INDICATOR signal, as long as the other receiver inputs are floating, or driven to GND (as in the case of a powered down driver). Connecting $\overline{\text{FORCEOFF}}$ and $\overline{\text{FORCEON}}$ together disables the automatic powerdown feature, enabling them to function as a manual SHUTDOWN input (See Figure 4).

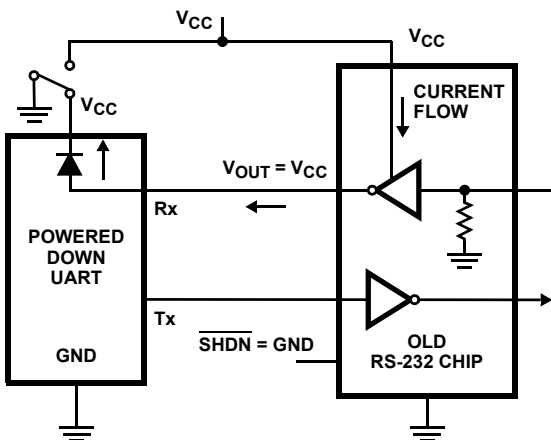

FIGURE 2. POWER DRAIN THROUGH POWERED DOWN PERIPHERAL

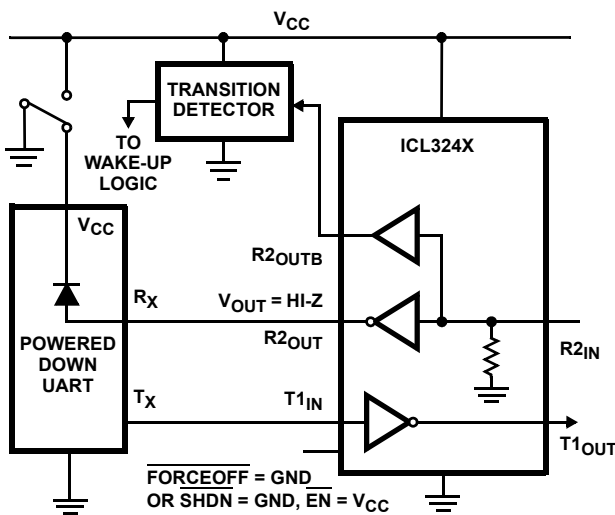

FIGURE 3. DISABLED RECEIVERS PREVENT POWER DRAIN

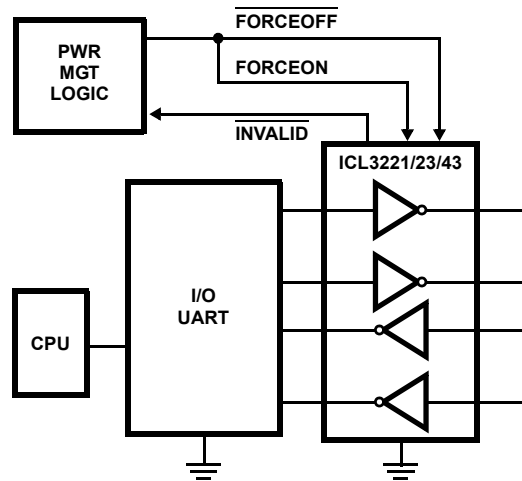

FIGURE 4. CONNECTIONS FOR MANUAL POWERDOWN WHEN NO VALID RECEIVER SIGNALS ARE PRESENT

With any of the above control schemes, the time required to exit powerdown, and resume transmission is only 100 μ s. A mouse, or other application, may need more time to wake up from shutdown. If automatic powerdown is being utilized, the RS-232 device will reenter powerdown if valid receiver levels aren't reestablished within 30 μ s of the ICL32XX powering up. Figure 5 illustrates a circuit that keeps the ICL32XX from initiating automatic powerdown for 100ms after powering up. This gives the slow-to-wake peripheral circuit time to reestablish valid RS-232 output levels.

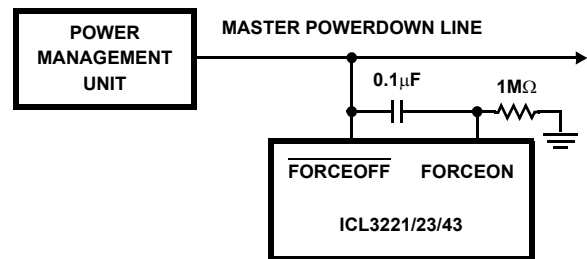

FIGURE 5. CIRCUIT TO PREVENT AUTO POWERDOWN FOR 100ms AFTER FORCED POWERUP

Automatic Powerdown (ICL3221/23/43 Only)

Even greater power savings is available by using the devices which feature an *automatic* powerdown function. When no valid RS-232 voltages (See Figure 6) are sensed on any receiver input for 30 μ s, the charge pump and transmitters powerdown, thereby reducing supply current to 1 μ A. Invalid receiver levels occur whenever the driving peripheral's outputs are shut off (powered down) or when the RS-232 interface cable is disconnected. The ICL32XX powers back up whenever it detects a valid RS-232 voltage level on any receiver input. This automatic powerdown feature provides additional system power savings without changes to the existing operating system.

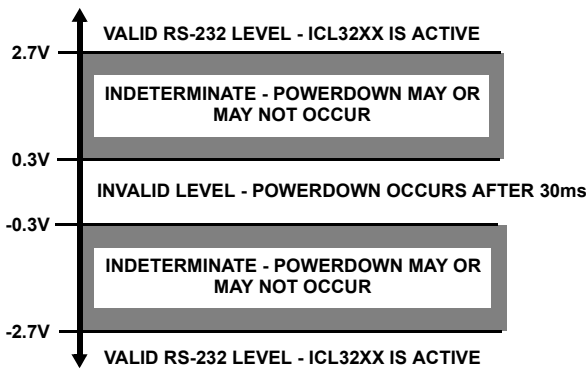

FIGURE 6. DEFINITION OF VALID RS-232 RECEIVER LEVELS

Automatic powerdown operates when the FORCEON input is low, and the FORCEOFF input is high. Tying FORCEON high disables automatic powerdown, but manual powerdown is always available via the overriding FORCEOFF input. Table 2 summarizes the automatic powerdown functionality.

Devices with the automatic powerdown feature include an INVALID output signal, which switches low to indicate that invalid levels have persisted on all of the receiver inputs for more than 30µs (See Figure 7). INVALID switches high 1µs after detecting a valid RS-232 level on a receiver input. INVALID operates in all modes (forced or automatic powerdown, or forced on), so it is also useful for systems employing manual powerdown circuitry. When automatic powerdown is utilized, INVALID = 0 indicates that the ICL32XX is in powerdown mode.

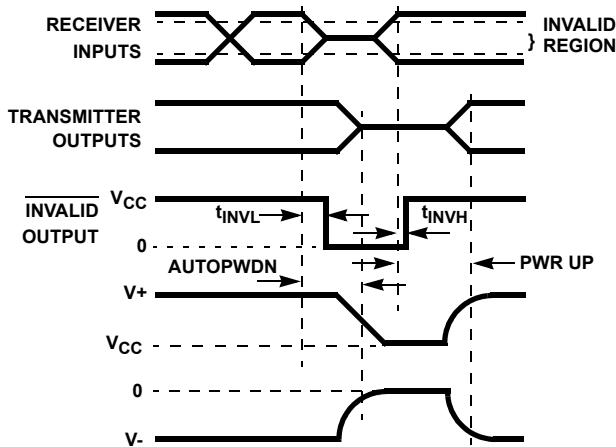

FIGURE 7. AUTOMATIC POWERDOWN AND INVALID TIMING DIAGRAMS

The time to recover from automatic powerdown mode is typically 100µs.

Receiver ENABLE Control (ICL3221/22/23/41 Only)

Several devices also feature an EN input to control the receiver outputs. Driving EN high disables all the inverting

(standard) receiver outputs placing them in a high impedance state. This is useful to eliminate supply current, due to a receiver output forward biasing the protection diode, when driving the input of a powered down (VCC = GND) peripheral (See Figure 2). The enable input has no effect on transmitter nor monitor (ROUTB) outputs.

Capacitor Selection

The charge pumps require 0.1µF capacitors for 3.3V operation. For other supply voltages refer to Table 3 for capacitor values. Do not use values smaller than those listed in Table 3. Increasing the capacitor values (by a factor of 2) reduces ripple on the transmitter outputs and slightly reduces power consumption. C2, C3, and C4 can be increased without increasing C1’s value, however, do not increase C1 without also increasing C2, C3, and C4 to maintain the proper ratios (C1 to the other capacitors).

When using minimum required capacitor values, make sure that capacitor values do not degrade excessively with temperature. If in doubt, use capacitors with a larger nominal value. The capacitor’s equivalent series resistance (ESR) usually rises at low temperatures and it influences the amount of ripple on V+ and V-.

TABLE 3. REQUIRED CAPACITOR VALUES

VCC (V)	C1 (µF)	C2, C3, C4 (µF)
3.0 to 3.6	0.1	0.1
4.5 to 5.5	0.047	0.33
3.0 to 5.5	0.1	0.47

Power Supply Decoupling

In most circumstances a 0.1µF bypass capacitor is adequate. In applications that are particularly sensitive to power supply noise, decouple VCC to ground with a capacitor of the same value as the charge-pump capacitor C1. Connect the bypass capacitor as close as possible to the IC.

Operation Down to 2.7V

ICL32XX transmitter outputs meet RS-562 levels (±3.7V), at full data rate, with VCC as low as 2.7V. RS-562 levels typically ensure interoperability with RS-232 devices.

Transmitter Outputs when Exiting Powerdown

Figure 8 shows the response of two transmitter outputs when exiting powerdown mode. As they activate, the two transmitter outputs properly go to opposite RS-232 levels, with no glitching, ringing, nor undesirable transients. Each transmitter is loaded with 3kΩ in parallel with 2500pF. Note that the transmitters enable only when the magnitude of the supplies exceed approximately 3V.

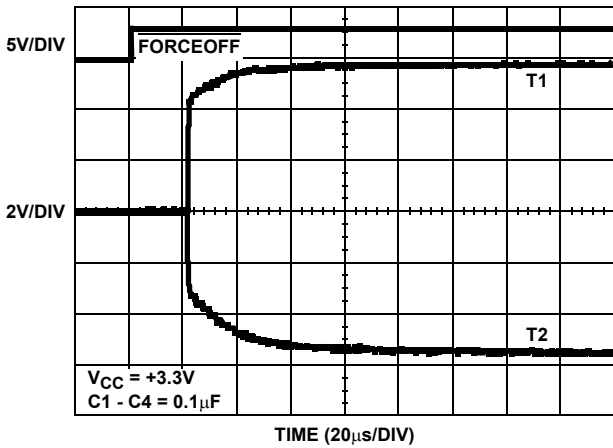

FIGURE 8. TRANSMITTER OUTPUTS WHEN EXITING POWERDOWN

Mouse Driveability

The ICL324X have been specifically designed to power a serial mouse while operating from low voltage supplies. Figure 9 shows the transmitter output voltages under increasing load current. The on-chip switching regulator ensures the transmitters will supply at least $\pm 5V$ during worst case conditions (15mA for paralleled V+ transmitters, 7.3mA for single V- transmitter). The Automatic Powerdown feature does not work with a mouse, so $\overline{\text{FORCEOFF}}$ and $\overline{\text{FORCEON}}$ should be connected to V_{CC} .

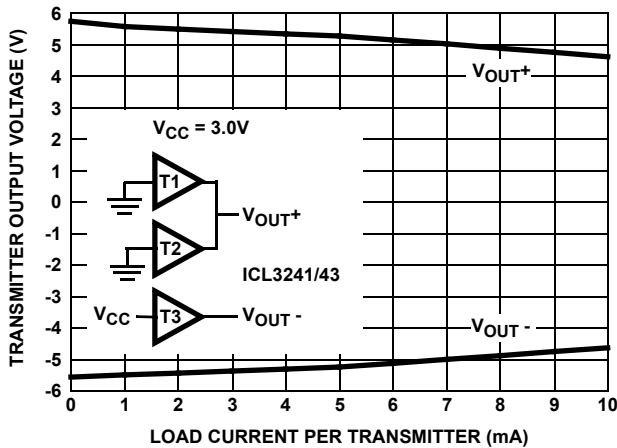

FIGURE 9. TRANSMITTER OUTPUT VOLTAGE vs LOAD CURRENT (PER TRANSMITTER, i.e., DOUBLE CURRENT AXIS FOR TOTAL V_{OUT+} CURRENT)

High Data Rates

The ICL32XX maintain the RS-232 $\pm 5V$ minimum transmitter output voltages even at high data rates. Figure 10 details a transmitter loopback test circuit, and Figure 11 illustrates the loopback test result at 120kbps. For this test, all transmitters were simultaneously driving RS-232 loads in parallel with 1000pF, at 120kbps. Figure 12 shows the loopback results

for a single transmitter driving 1000pF and an RS-232 load at 250kbps. The static transmitters were also loaded with an RS-232 receiver.

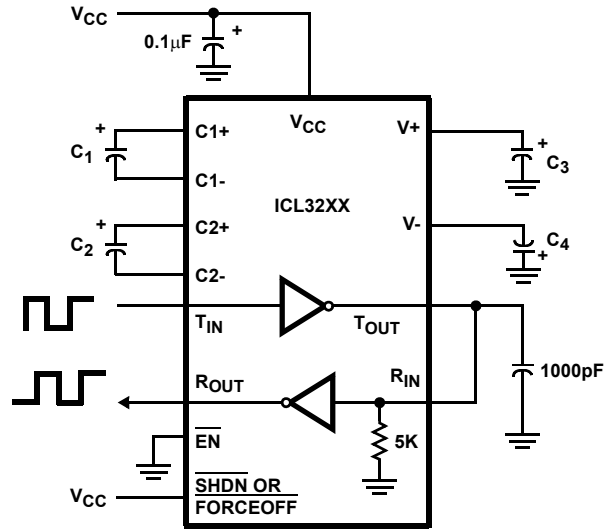

FIGURE 10. TRANSMITTER LOOPBACK TEST CIRCUIT

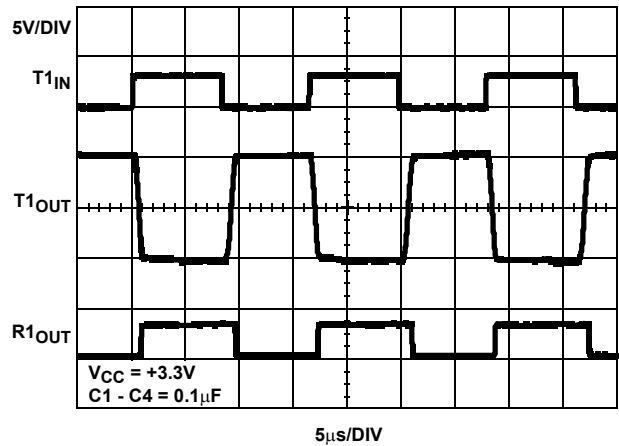

FIGURE 11. LOOPBACK TEST AT 120kbps

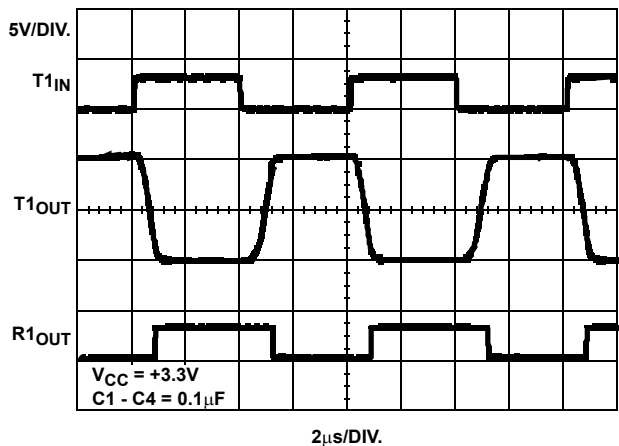

FIGURE 12. LOOPBACK TEST AT 250kbps

Interconnection with 3V and 5V Logic

The ICL32XX directly interface with 5V CMOS and TTL logic families. Nevertheless, with the ICL32XX at 3.3V, and the logic supply at 5V, AC, HC, and CD4000 outputs can drive ICL32XX inputs, but ICL32XX outputs do not reach the minimum V_{IH} for these logic families. See Table 4 for more information.

TABLE 4. LOGIC FAMILY COMPATIBILITY WITH VARIOUS SUPPLY VOLTAGES

SYSTEM POWER-SUPPLY VOLTAGE (V)	V _{CC} SUPPLY VOLTAGE (V)	COMPATIBILITY
3.3	3.3	Compatible with all CMOS families.
5	5	Compatible with all TTL and CMOS logic families.
5	3.3	Compatible with ACT and HCT CMOS, and with TTL. ICL32XX outputs are incompatible with AC, HC, and CD4000 CMOS inputs.

Typical Performance Curves V_{CC} = 3.3V, T_A = 25°C

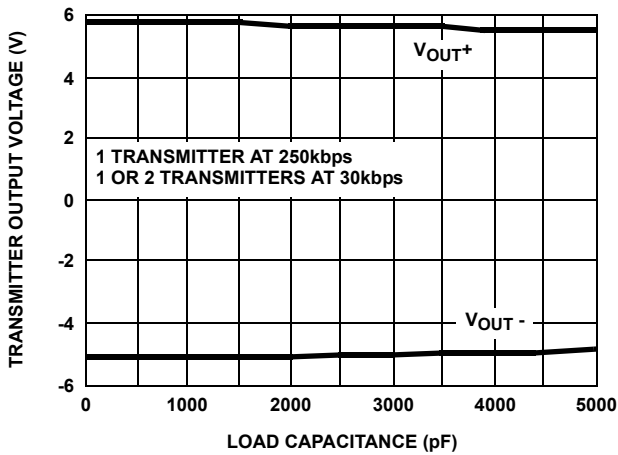

FIGURE 13. TRANSMITTER OUTPUT VOLTAGE vs LOAD CAPACITANCE

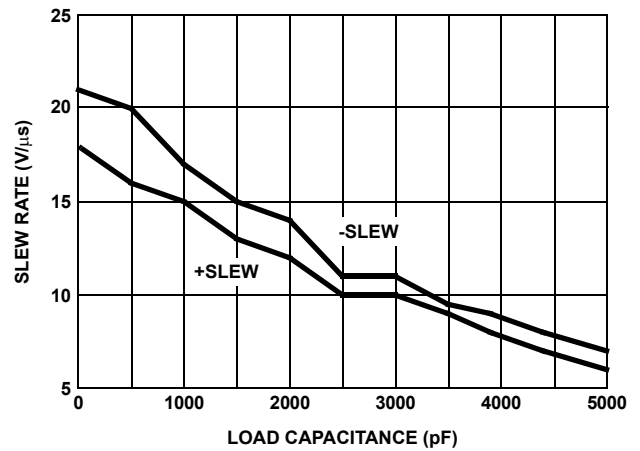

FIGURE 14. SLEW RATE vs LOAD CAPACITANCE

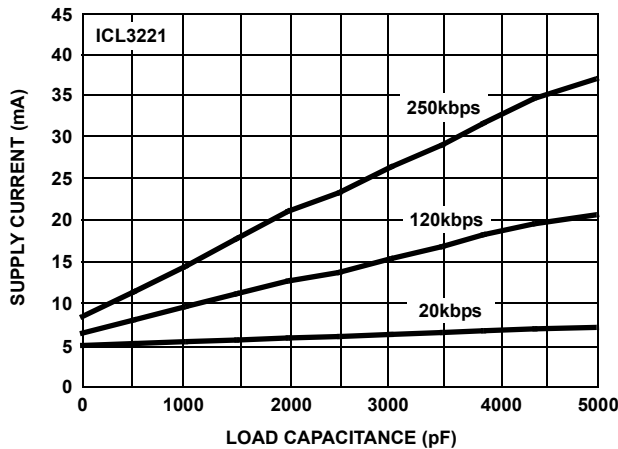

FIGURE 15. SUPPLY CURRENT vs LOAD CAPACITANCE WHEN TRANSMITTING DATA

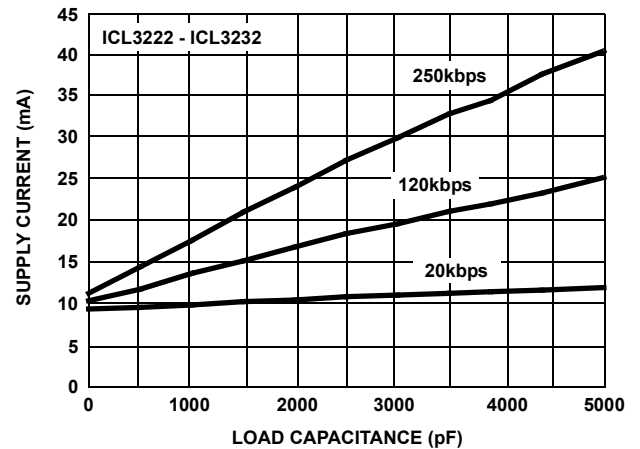

FIGURE 16. SUPPLY CURRENT vs LOAD CAPACITANCE WHEN TRANSMITTING DATA

Typical Performance Curves VCC = 3.3V, TA = 25°C (Continued)

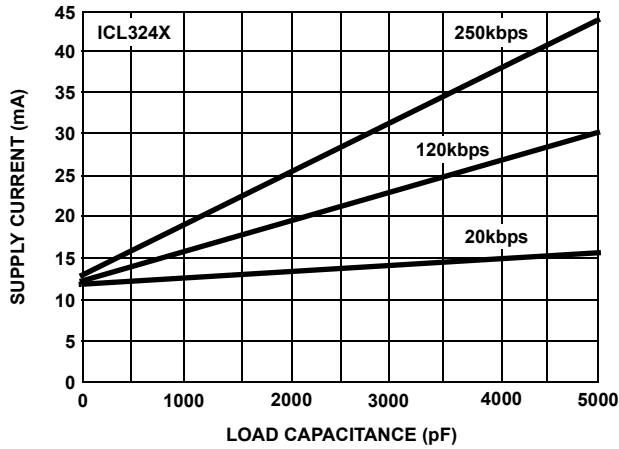

FIGURE 17. SUPPLY CURRENT vs LOAD CAPACITANCE WHEN TRANSMITTING DATA

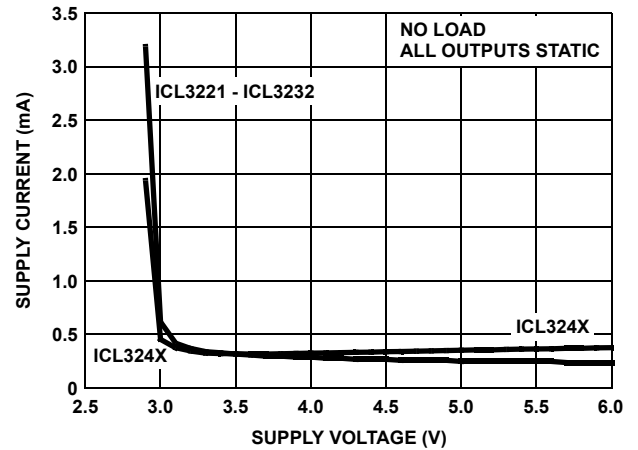

FIGURE 18. SUPPLY CURRENT vs SUPPLY VOLTAGE

Die Characteristics

SUBSTRATE POTENTIAL (POWERED UP):

GND

TRANSISTOR COUNT:

- ICL3221: 286
- ICL3222: 338
- ICL3223: 357
- ICL3232: 296
- ICL324X: 464

PROCESS:

Si Gate CMOS

Dual-In-Line Plastic Packages (PDIP)

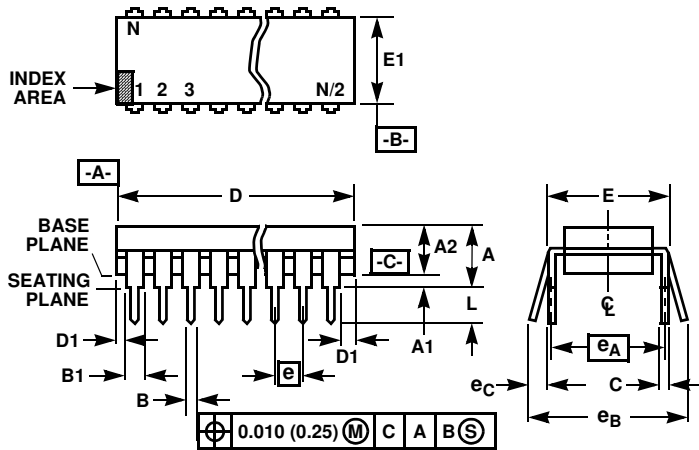

NOTES:

- Controlling Dimensions: INCH. In case of conflict between English and Metric dimensions, the inch dimensions control.
- Dimensioning and tolerancing per ANSI Y14.5M-1982.
- Symbols are defined in the "MO Series Symbol List" in Section 2.2 of Publication No. 95.
- Dimensions A, A1 and L are measured with the package seated in JEDEC seating plane gauge GS-3.
- D, D1, and E1 dimensions do not include mold flash or protrusions. Mold flash or protrusions shall not exceed 0.010 inch (0.25mm).
- E and e_A are measured with the leads constrained to be perpendicular to datum $-C-$.
- e_B and e_C are measured at the lead tips with the leads unconstrained. e_C must be zero or greater.
- B1 maximum dimensions do not include dambar protrusions. Dambar protrusions shall not exceed 0.010 inch (0.25mm).
- N is the maximum number of terminal positions.
- Corner leads (1, N, N/2 and N/2 + 1) for E8.3, E16.3, E18.3, E28.3, E42.6 will have a B1 dimension of 0.030 - 0.045 inch (0.76 - 1.14mm).

E16.3 (JEDEC MS-001-BB ISSUE D)
16 LEAD DUAL-IN-LINE PLASTIC PACKAGE

SYMBOL	INCHES		MILLIMETERS		NOTES
	MIN	MAX	MIN	MAX	
A	-	0.210	-	5.33	4
A1	0.015	-	0.39	-	4
A2	0.115	0.195	2.93	4.95	-
B	0.014	0.022	0.356	0.558	-
B1	0.045	0.070	1.15	1.77	8, 10
C	0.008	0.014	0.204	0.355	-
D	0.735	0.775	18.66	19.68	5
D1	0.005	-	0.13	-	5
E	0.300	0.325	7.62	8.25	6
E1	0.240	0.280	6.10	7.11	5
e	0.100 BSC		2.54 BSC		-
e_A	0.300 BSC		7.62 BSC		6
e_B	-	0.430	-	10.92	7
L	0.115	0.150	2.93	3.81	4
N	16		16		9

Rev. 0 12/93

Dual-In-Line Plastic Packages (PDIP)

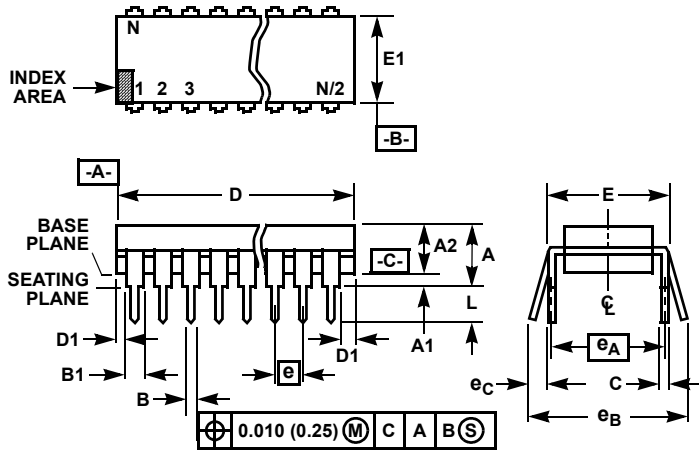

NOTES:

- Controlling Dimensions: INCH. In case of conflict between English and Metric dimensions, the inch dimensions control.
- Dimensioning and tolerancing per ANSI Y14.5M-1982.
- Symbols are defined in the "MO Series Symbol List" in Section 2.2 of Publication No. 95.
- Dimensions A, A1 and L are measured with the package seated in JEDEC seating plane gauge GS-3.
- D, D1, and E1 dimensions do not include mold flash or protrusions. Mold flash or protrusions shall not exceed 0.010 inch (0.25mm).
- E and e_A are measured with the leads constrained to be perpendicular to datum $-C-$.
- e_B and e_C are measured at the lead tips with the leads unconstrained. e_C must be zero or greater.
- B1 maximum dimensions do not include dambar protrusions. Dambar protrusions shall not exceed 0.010 inch (0.25mm).
- N is the maximum number of terminal positions.
- Corner leads (1, N, N/2 and N/2 + 1) for E8.3, E16.3, E18.3, E28.3 may have a B1 dimension of 0.030 - 0.045 inch (0.76 - 1.14mm).

E18.3 (JEDEC MS-001-BC ISSUE D)
18 LEAD DUAL-IN-LINE PLASTIC PACKAGE

SYMBOL	INCHES		MILLIMETERS		NOTES
	MIN	MAX	MIN	MAX	
A	-	0.210	-	5.33	4
A1	0.015	-	0.39	-	4
A2	0.115	0.195	2.93	4.95	-
B	0.014	0.022	0.356	0.558	-
B1	0.045	0.070	1.15	1.77	8, 10
C	0.008	0.014	0.204	0.355	-
D	0.845	0.880	21.47	22.35	5
D1	0.005	-	0.13	-	5
E	0.300	0.325	7.62	8.25	6
E1	0.240	0.280	6.10	7.11	5
e	0.100 BSC		2.54 BSC		-
e_A	0.300 BSC		7.62 BSC		6
e_B	-	0.430	-	10.92	7
L	0.115	0.150	2.93	3.81	4
N	18		18		9

Rev. 2 11/03

Small Outline Plastic Packages (SOIC)

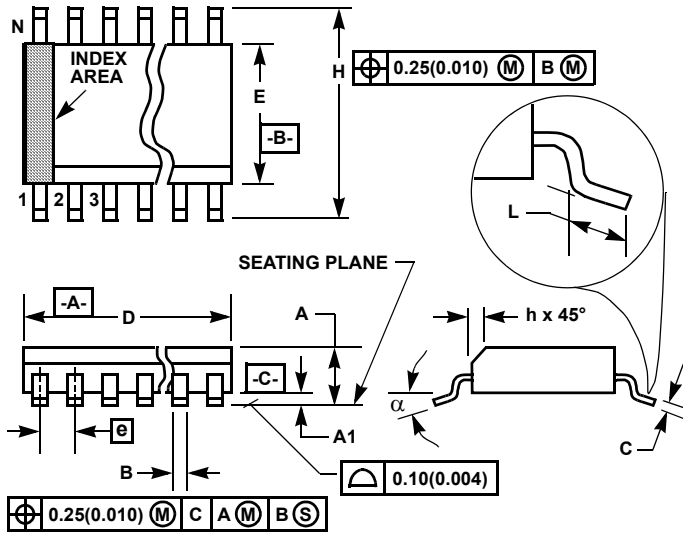

M16.15 (JEDEC MS-012-AC ISSUE C)
16 LEAD NARROW BODY SMALL OUTLINE PLASTIC PACKAGE

SYMBOL	INCHES		MILLIMETERS		NOTES
	MIN	MAX	MIN	MAX	
A	0.0532	0.0688	1.35	1.75	-
A1	0.0040	0.0098	0.10	0.25	-
B	0.013	0.020	0.33	0.51	9
C	0.0075	0.0098	0.19	0.25	-
D	0.3859	0.3937	9.80	10.00	3
E	0.1497	0.1574	3.80	4.00	4
e	0.050 BSC		1.27 BSC		-
H	0.2284	0.2440	5.80	6.20	-
h	0.0099	0.0196	0.25	0.50	5
L	0.016	0.050	0.40	1.27	6
N	16		16		7
α	0°	8°	0°	8°	-

NOTES:

1. Symbols are defined in the "MO Series Symbol List" in Section 2.2 of Publication Number 95.
2. Dimensioning and tolerancing per ANSI Y14.5M-1982.
3. Dimension "D" does not include mold flash, protrusions or gate burrs. Mold flash, protrusion and gate burrs shall not exceed 0.15mm (0.006 inch) per side.
4. Dimension "E" does not include interlead flash or protrusions. Interlead flash and protrusions shall not exceed 0.25mm (0.010 inch) per side.
5. The chamfer on the body is optional. If it is not present, a visual index feature must be located within the crosshatched area.
6. "L" is the length of terminal for soldering to a substrate.
7. "N" is the number of terminal positions.
8. Terminal numbers are shown for reference only.
9. The lead width "B", as measured 0.36mm (0.014 inch) or greater above the seating plane, shall not exceed a maximum value of 0.61mm (0.024 inch).
10. Controlling dimension: MILLIMETER. Converted inch dimensions are not necessarily exact.

Rev. 1 6/05

Thin Shrink Small Outline Plastic Packages (TSSOP)

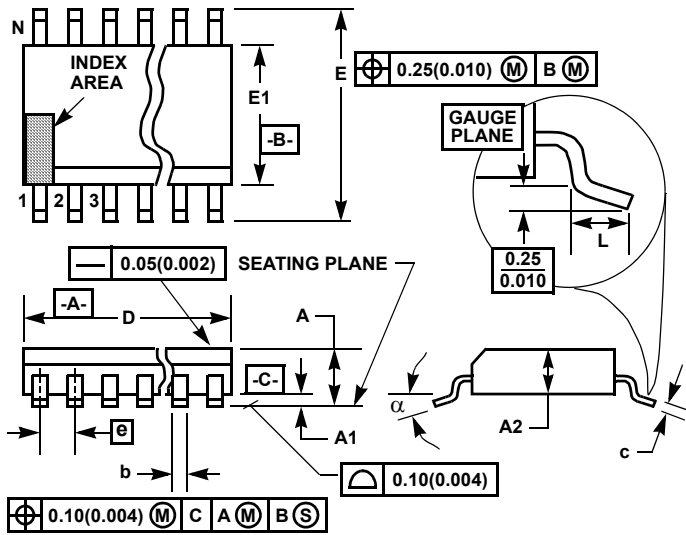

M16.173
16 LEAD THIN SHRINK SMALL OUTLINE PLASTIC PACKAGE

SYMBOL	INCHES		MILLIMETERS		NOTES
	MIN	MAX	MIN	MAX	
A	-	0.043	-	1.10	-
A1	0.002	0.006	0.05	0.15	-
A2	0.033	0.037	0.85	0.95	-
b	0.0075	0.012	0.19	0.30	9
c	0.0035	0.008	0.09	0.20	-
D	0.193	0.201	4.90	5.10	3
E1	0.169	0.177	4.30	4.50	4
e	0.026 BSC		0.65 BSC		-
E	0.246	0.256	6.25	6.50	-
L	0.020	0.028	0.50	0.70	6
N	16		16		7
α	0°	8°	0°	8°	-

NOTES:

1. These package dimensions are within allowable dimensions of JEDEC MO-153-AB, Issue E.
2. Dimensioning and tolerancing per ANSI Y14.5M-1982.
3. Dimension "D" does not include mold flash, protrusions or gate burrs. Mold flash, protrusion and gate burrs shall not exceed 0.15mm (0.006 inch) per side.
4. Dimension "E1" does not include interlead flash or protrusions. Interlead flash and protrusions shall not exceed 0.15mm (0.006 inch) per side.
5. The chamfer on the body is optional. If it is not present, a visual index feature must be located within the crosshatched area.
6. "L" is the length of terminal for soldering to a substrate.
7. "N" is the number of terminal positions.
8. Terminal numbers are shown for reference only.
9. Dimension "b" does not include dambar protrusion. Allowable dambar protrusion shall be 0.08mm (0.003 inch) total in excess of "b" dimension at maximum material condition. Minimum space between protrusion and adjacent lead is 0.07mm (0.0027 inch).
10. Controlling dimension: MILLIMETER. Converted inch dimensions are not necessarily exact. (Angles in degrees)

Rev. 1 2/02

Small Outline Plastic Packages (SSOP)

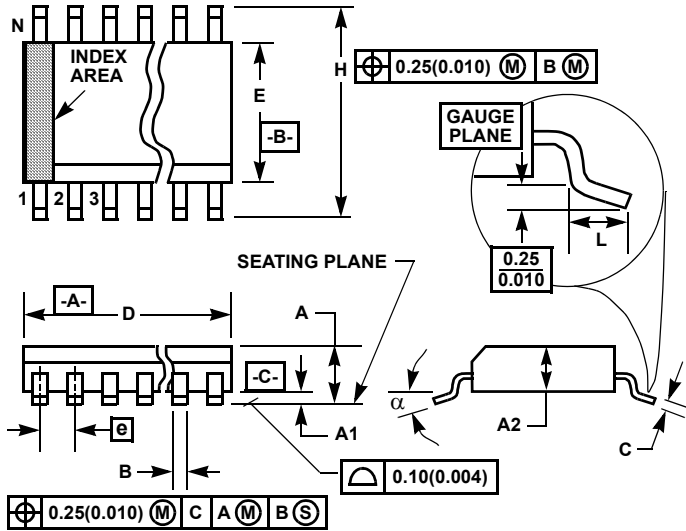

M16.209 (JEDEC MO-150-AC ISSUE B)
16 LEAD SHRINK SMALL OUTLINE PLASTIC PACKAGE

SYMBOL	INCHES		MILLIMETERS		NOTES
	MIN	MAX	MIN	MAX	
A	-	0.078	-	2.00	-
A1	0.002	-	0.05	-	-
A2	0.065	0.072	1.65	1.85	-
B	0.009	0.014	0.22	0.38	9
C	0.004	0.009	0.09	0.25	-
D	0.233	0.255	5.90	6.50	3
E	0.197	0.220	5.00	5.60	4
e	0.026 BSC		0.65 BSC		-
H	0.292	0.322	7.40	8.20	-
L	0.022	0.037	0.55	0.95	6
N	16		16		7
alpha	0°	8°	0°	8°	-

NOTES:

1. Symbols are defined in the "MO Series Symbol List" in Section 2.2 of Publication Number 95.
2. Dimensioning and tolerancing per ANSI Y14.5M-1982.
3. Dimension "D" does not include mold flash, protrusions or gate burrs. Mold flash, protrusion and gate burrs shall not exceed 0.20mm (0.0078 inch) per side.
4. Dimension "E" does not include interlead flash or protrusions. Interlead flash and protrusions shall not exceed 0.20mm (0.0078 inch) per side.
5. The chamfer on the body is optional. If it is not present, a visual index feature must be located within the crosshatched area.
6. "L" is the length of terminal for soldering to a substrate.
7. "N" is the number of terminal positions.
8. Terminal numbers are shown for reference only.
9. Dimension "B" does not include dambar protrusion. Allowable dambar protrusion shall be 0.13mm (0.005 inch) total in excess of "B" dimension at maximum material condition.
10. Controlling dimension: MILLIMETER. Converted inch dimensions are not necessarily exact.

Rev. 3 6/05

Small Outline Plastic Packages (SOIC)

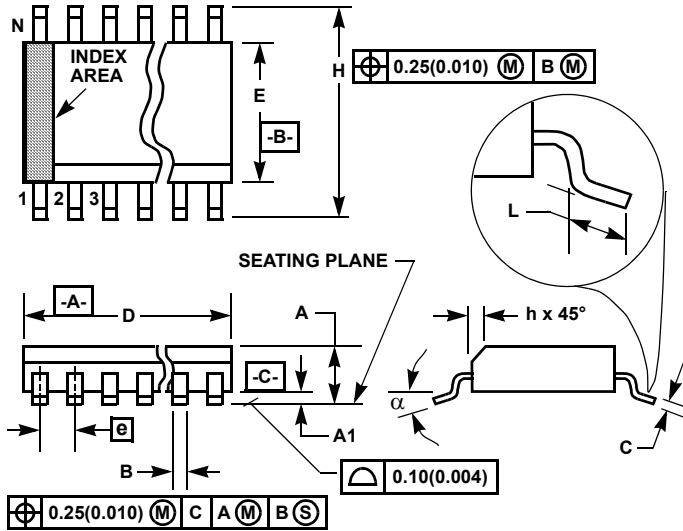

M16.3 (JEDEC MS-013-AA ISSUE C)
16 LEAD WIDE BODY SMALL OUTLINE PLASTIC PACKAGE

SYMBOL	INCHES		MILLIMETERS		NOTES
	MIN	MAX	MIN	MAX	
A	0.0926	0.1043	2.35	2.65	-
A1	0.0040	0.0118	0.10	0.30	-
B	0.013	0.0200	0.33	0.51	9
C	0.0091	0.0125	0.23	0.32	-
D	0.3977	0.4133	10.10	10.50	3
E	0.2914	0.2992	7.40	7.60	4
e	0.050 BSC		1.27 BSC		-
H	0.394	0.419	10.00	10.65	-
h	0.010	0.029	0.25	0.75	5
L	0.016	0.050	0.40	1.27	6
N	16		16		7
alpha	0°	8°	0°	8°	-

NOTES:

1. Symbols are defined in the "MO Series Symbol List" in Section 2.2 of Publication Number 95.
2. Dimensioning and tolerancing per ANSI Y14.5M-1982.
3. Dimension "D" does not include mold flash, protrusions or gate burrs. Mold flash, protrusion and gate burrs shall not exceed 0.15mm (0.006 inch) per side.
4. Dimension "E" does not include interlead flash or protrusions. Interlead flash and protrusions shall not exceed 0.25mm (0.010 inch) per side.
5. The chamfer on the body is optional. If it is not present, a visual index feature must be located within the crosshatched area.
6. "L" is the length of terminal for soldering to a substrate.
7. "N" is the number of terminal positions.
8. Terminal numbers are shown for reference only.
9. The lead width "B", as measured 0.36mm (0.014 inch) or greater above the seating plane, shall not exceed a maximum value of 0.61mm (0.024 inch)
10. Controlling dimension: MILLIMETER. Converted inch dimensions are not necessarily exact.

Rev. 1 6/05

Small Outline Plastic Packages (SOIC)

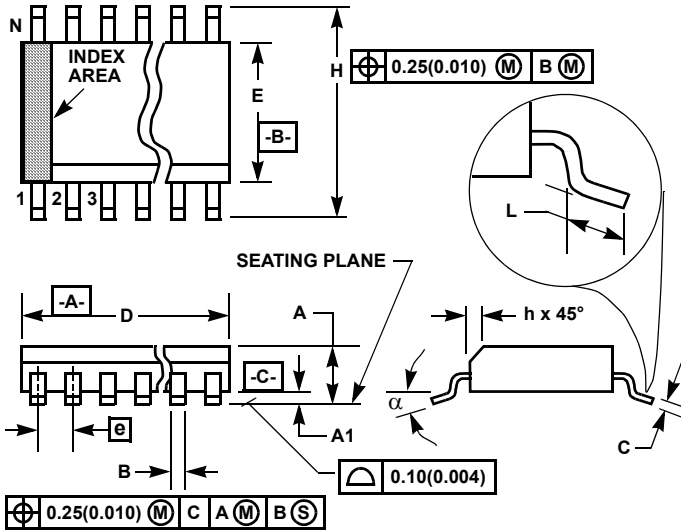

M18.3 (JEDEC MS-013-AB ISSUE C)
18 LEAD WIDE BODY SMALL OUTLINE PLASTIC PACKAGE

SYMBOL	INCHES		MILLIMETERS		NOTES
	MIN	MAX	MIN	MAX	
A	0.0926	0.1043	2.35	2.65	-
A1	0.0040	0.0118	0.10	0.30	-
B	0.013	0.0200	0.33	0.51	9
C	0.0091	0.0125	0.23	0.32	-
D	0.4469	0.4625	11.35	11.75	3
E	0.2914	0.2992	7.40	7.60	4
e	0.050 BSC		1.27 BSC		-
H	0.394	0.419	10.00	10.65	-
h	0.010	0.029	0.25	0.75	5
L	0.016	0.050	0.40	1.27	6
N	18		18		7
α	0°	8°	0°	8°	-

NOTES:

1. Symbols are defined in the "MO Series Symbol List" in Section 2.2 of Publication Number 95.
2. Dimensioning and tolerancing per ANSI Y14.5M-1982.
3. Dimension "D" does not include mold flash, protrusions or gate burrs. Mold flash, protrusion and gate burrs shall not exceed 0.15mm (0.006 inch) per side.
4. Dimension "E" does not include interlead flash or protrusions. Interlead flash and protrusions shall not exceed 0.25mm (0.010 inch) per side.
5. The chamfer on the body is optional. If it is not present, a visual index feature must be located within the crosshatched area.
6. "L" is the length of terminal for soldering to a substrate.
7. "N" is the number of terminal positions.
8. Terminal numbers are shown for reference only.
9. The lead width "B", as measured 0.36mm (0.014 inch) or greater above the seating plane, shall not exceed a maximum value of 0.61mm (0.024 inch)
10. Controlling dimension: MILLIMETER. Converted inch dimensions are not necessarily exact.

Rev. 1 6/05

Thin Shrink Small Outline Plastic Packages (TSSOP)

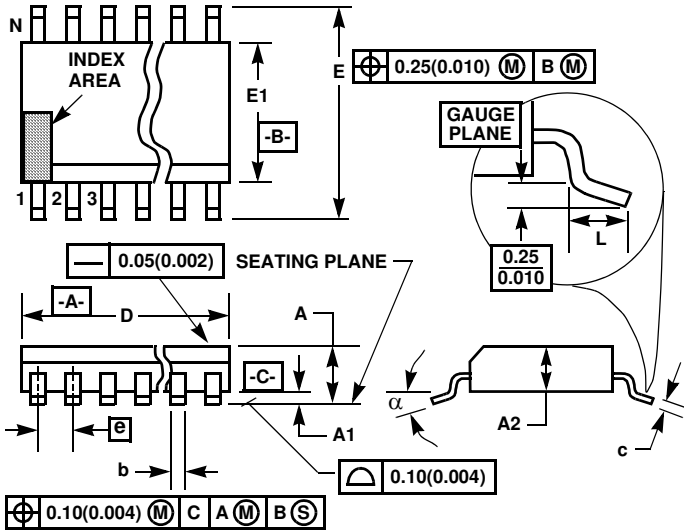

M20.173
20 LEAD THIN SHRINK SMALL OUTLINE PLASTIC PACKAGE

SYMBOL	INCHES		MILLIMETERS		NOTES
	MIN	MAX	MIN	MAX	
A	-	0.047	-	1.20	-
A1	0.002	0.006	0.05	0.15	-
A2	0.031	0.051	0.80	1.05	-
b	0.0075	0.0118	0.19	0.30	9
c	0.0035	0.0079	0.09	0.20	-
D	0.252	0.260	6.40	6.60	3
E1	0.169	0.177	4.30	4.50	4
e	0.026 BSC		0.65 BSC		-
E	0.246	0.256	6.25	6.50	-
L	0.0177	0.0295	0.45	0.75	6
N	20		20		7
α	0°	8°	0°	8°	-

NOTES:

1. These package dimensions are within allowable dimensions of JEDEC MO-153-AC, Issue E.
2. Dimensioning and tolerancing per ANSI Y14.5M-1982.
3. Dimension "D" does not include mold flash, protrusions or gate burrs. Mold flash, protrusion and gate burrs shall not exceed 0.15mm (0.006 inch) per side.
4. Dimension "E1" does not include interlead flash or protrusions. Interlead flash and protrusions shall not exceed 0.15mm (0.006 inch) per side.
5. The chamfer on the body is optional. If it is not present, a visual index feature must be located within the crosshatched area.
6. "L" is the length of terminal for soldering to a substrate.
7. "N" is the number of terminal positions.
8. Terminal numbers are shown for reference only.
9. Dimension "b" does not include dambar protrusion. Allowable dambar protrusion shall be 0.08mm (0.003 inch) total in excess of "b" dimension at maximum material condition. Minimum space between protrusion and adjacent lead is 0.07mm (0.0027 inch).
10. Controlling dimension: MILLIMETER. Converted inch dimensions are not necessarily exact. (Angles in degrees)

Rev. 1 6/98

Shrink Small Outline Plastic Packages (SSOP)

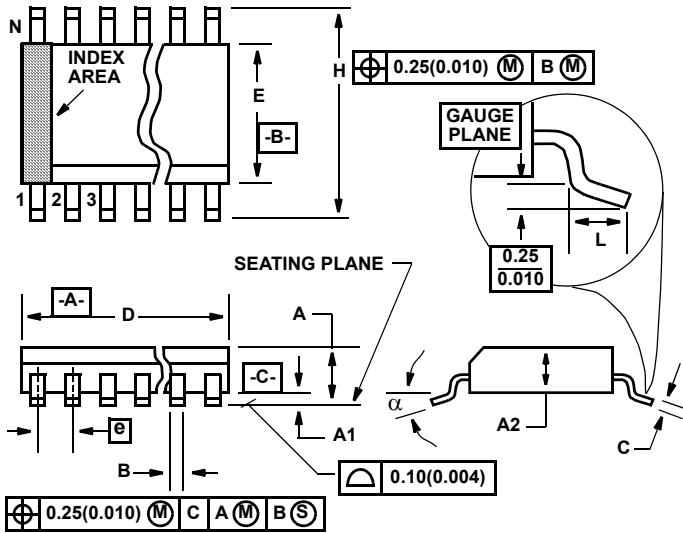

M20.209 (JEDEC MO-150-AE ISSUE B)
20 LEAD SHRINK SMALL OUTLINE PLASTIC PACKAGE

SYMBOL	INCHES		MILLIMETERS		NOTES
	MIN	MAX	MIN	MAX	
A	0.068	0.078	1.73	1.99	
A1	0.002	0.008'	0.05	0.21	
A2	0.066	0.070'	1.68	1.78	
B	0.010'	0.015	0.25	0.38	9
C	0.004	0.008	0.09	0.20'	
D	0.278	0.289	7.07	7.33	3
E	0.205	0.212	5.20'	5.38	4
e	0.026 BSC		0.65 BSC		
H	0.301	0.311	7.65	7.90'	
L	0.025	0.037	0.63	0.95	6
N	20		20		7
α	0 deg.	8 deg.	0 deg.	8 deg.	

NOTES:

1. Symbols are defined in the "MO Series Symbol List" in Section 2.2 of Publication Number 95.
2. Dimensioning and tolerancing per ANSI Y14.5M-1982.
3. Dimension "D" does not include mold flash, protrusions or gate burrs. Mold flash, protrusion and gate burrs shall not exceed 0.20mm (0.0078 inch) per side.
4. Dimension "E" does not include interlead flash or protrusions. Interlead flash and protrusions shall not exceed 0.20mm (0.0078 inch) per side.
5. The chamfer on the body is optional. If it is not present, a visual index feature must be located within the crosshatched area.
6. "L" is the length of terminal for soldering to a substrate.
7. "N" is the number of terminal positions.
8. Terminal numbers are shown for reference only.
9. Dimension "B" does not include dambar protrusion. Allowable dambar protrusion shall be 0.13mm (0.005 inch) total in excess of "B" dimension at maximum material condition.
10. Controlling dimension: MILLIMETER. Converted inch dimensions are not necessarily exact.

Rev. 3 11/02

Thin Shrink Small Outline Plastic Packages (TSSOP)

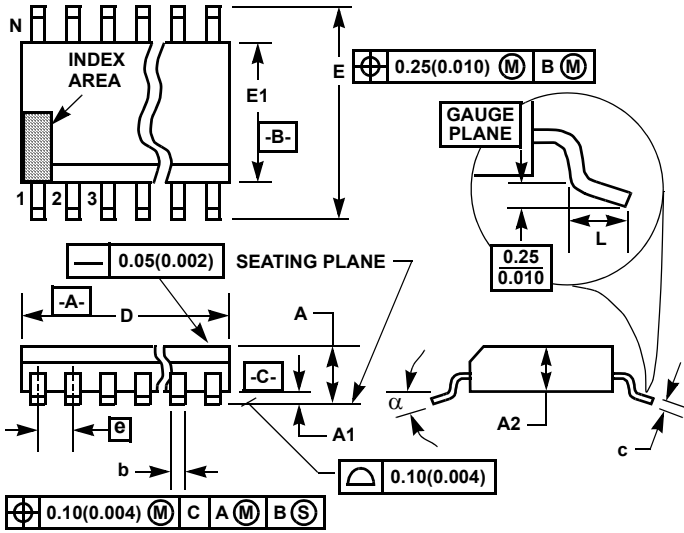

M28.173
28 LEAD THIN SHRINK SMALL OUTLINE PLASTIC PACKAGE

SYMBOL	INCHES		MILLIMETERS		NOTES
	MIN	MAX	MIN	MAX	
A	-	0.047	-	1.20	-
A1	0.002	0.006	0.05	0.15	-
A2	0.031	0.051	0.80	1.05	-
b	0.0075	0.0118	0.19	0.30	9
c	0.0035	0.0079	0.09	0.20	-
D	0.378	0.386	9.60	9.80	3
E1	0.169	0.177	4.30	4.50	4
e	0.026 BSC		0.65 BSC		-
E	0.246	0.256	6.25	6.50	-
L	0.0177	0.0295	0.45	0.75	6
N	28		28		7
α	0°	8°	0°	8°	-

NOTES:

1. These package dimensions are within allowable dimensions of JEDEC MO-153-AE, Issue E.
2. Dimensioning and tolerancing per ANSI Y14.5M-1982.
3. Dimension "D" does not include mold flash, protrusions or gate burrs. Mold flash, protrusion and gate burrs shall not exceed 0.15mm (0.006 inch) per side.
4. Dimension "E1" does not include interlead flash or protrusions. Interlead flash and protrusions shall not exceed 0.15mm (0.006 inch) per side.
5. The chamfer on the body is optional. If it is not present, a visual index feature must be located within the crosshatched area.
6. "L" is the length of terminal for soldering to a substrate.
7. "N" is the number of terminal positions.
8. Terminal numbers are shown for reference only.
9. Dimension "b" does not include dambar protrusion. Allowable dambar protrusion shall be 0.08mm (0.003 inch) total in excess of "b" dimension at maximum material condition. Minimum space between protrusion and adjacent lead is 0.07mm (0.0027 inch).
10. Controlling dimension: MILLIMETER. Converted inch dimensions are not necessarily exact. (Angles in degrees)

Rev. 0 6/98

Shrink Small Outline Plastic Packages (SSOP)

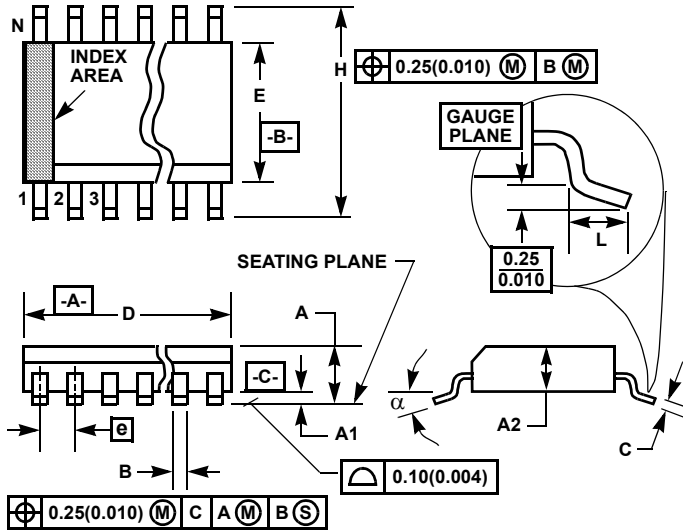

M28.209 (JEDEC MO-150-AH ISSUE B)
28 LEAD SHRINK SMALL OUTLINE PLASTIC PACKAGE

SYMBOL	INCHES		MILLIMETERS		NOTES
	MIN	MAX	MIN	MAX	
A	-	0.078	-	2.00	-
A1	0.002	-	0.05	-	-
A2	0.065	0.072	1.65	1.85	-
B	0.009	0.014	0.22	0.38	9
C	0.004	0.009	0.09	0.25	-
D	0.390	0.413	9.90	10.50	3
E	0.197	0.220	5.00	5.60	4
e	0.026 BSC		0.65 BSC		-
H	0.292	0.322	7.40	8.20	-
L	0.022	0.037	0.55	0.95	6
N	28		28		7
α	0°	8°	0°	8°	-

NOTES:

1. Symbols are defined in the "MO Series Symbol List" in Section 2.2 of Publication Number 95.
2. Dimensioning and tolerancing per ANSI Y14.5M-1982.
3. Dimension "D" does not include mold flash, protrusions or gate burrs. Mold flash, protrusion and gate burrs shall not exceed 0.20mm (0.0078 inch) per side.
4. Dimension "E" does not include interlead flash or protrusions. Interlead flash and protrusions shall not exceed 0.20mm (0.0078 inch) per side.
5. The chamfer on the body is optional. If it is not present, a visual index feature must be located within the crosshatched area.
6. "L" is the length of terminal for soldering to a substrate.
7. "N" is the number of terminal positions.
8. Terminal numbers are shown for reference only.
9. Dimension "B" does not include dambar protrusion. Allowable dambar protrusion shall be 0.13mm (0.005 inch) total in excess of "B" dimension at maximum material condition.
10. Controlling dimension: MILLIMETER. Converted inch dimensions are not necessarily exact.

Rev. 2 6/05

Small Outline Plastic Packages (SOIC)

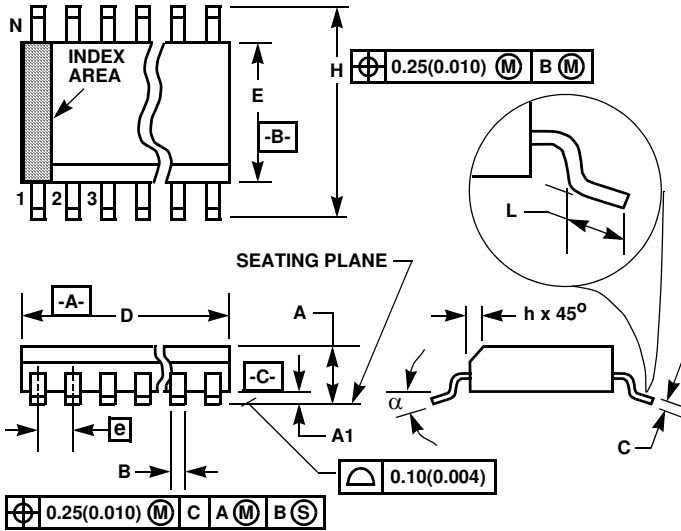

M28.3 (JEDEC MS-013-AE ISSUE C)
28 LEAD WIDE BODY SMALL OUTLINE PLASTIC PACKAGE

SYMBOL	INCHES		MILLIMETERS		NOTES
	MIN	MAX	MIN	MAX	
A	0.0926	0.1043	2.35	2.65	-
A1	0.0040	0.0118	0.10	0.30	-
B	0.013	0.0200	0.33	0.51	9
C	0.0091	0.0125	0.23	0.32	-
D	0.6969	0.7125	17.70	18.10	3
E	0.2914	0.2992	7.40	7.60	4
e	0.05 BSC		1.27 BSC		-
H	0.394	0.419	10.00	10.65	-
h	0.01	0.029	0.25	0.75	5
L	0.016	0.050	0.40	1.27	6
N	28		28		7
alpha	0°	8°	0°	8°	-

NOTES:

1. Symbols are defined in the "MO Series Symbol List" in Section 2.2 of Publication Number 95.
2. Dimensioning and tolerancing per ANSI Y14.5M-1982.
3. Dimension "D" does not include mold flash, protrusions or gate burrs. Mold flash, protrusion and gate burrs shall not exceed 0.15mm (0.006 inch) per side.
4. Dimension "E" does not include interlead flash or protrusions. Interlead flash and protrusions shall not exceed 0.25mm (0.010 inch) per side.
5. The chamfer on the body is optional. If it is not present, a visual index feature must be located within the crosshatched area.
6. "L" is the length of terminal for soldering to a substrate.
7. "N" is the number of terminal positions.
8. Terminal numbers are shown for reference only.
9. The lead width "B", as measured 0.36mm (0.014 inch) or greater above the seating plane, shall not exceed a maximum value of 0.61mm (0.024 inch)
10. Controlling dimension: MILLIMETER. Converted inch dimensions are not necessarily exact.

Rev. 0 12/93

All Intersil U.S. products are manufactured, assembled and tested utilizing ISO9000 quality systems.
Intersil Corporation's quality certifications can be viewed at www.intersil.com/design/quality

Intersil products are sold by description only. Intersil Corporation reserves the right to make changes in circuit design, software and/or specifications at any time without notice. Accordingly, the reader is cautioned to verify that data sheets are current before placing orders. Information furnished by Intersil is believed to be accurate and reliable. However, no responsibility is assumed by Intersil or its subsidiaries for its use; nor for any infringements of patents or other rights of third parties which may result from its use. No license is granted by implication or otherwise under any patent or patent rights of Intersil or its subsidiaries.

For information regarding Intersil Corporation and its products, see www.intersil.com