

LOC		DIST		REVISIONS			
GP	00	P	LTN	DESCRIPTION	DATE	DWN	APVD
		B7		REV PER ECR-13-004638	20MAR2013	ML	SZ

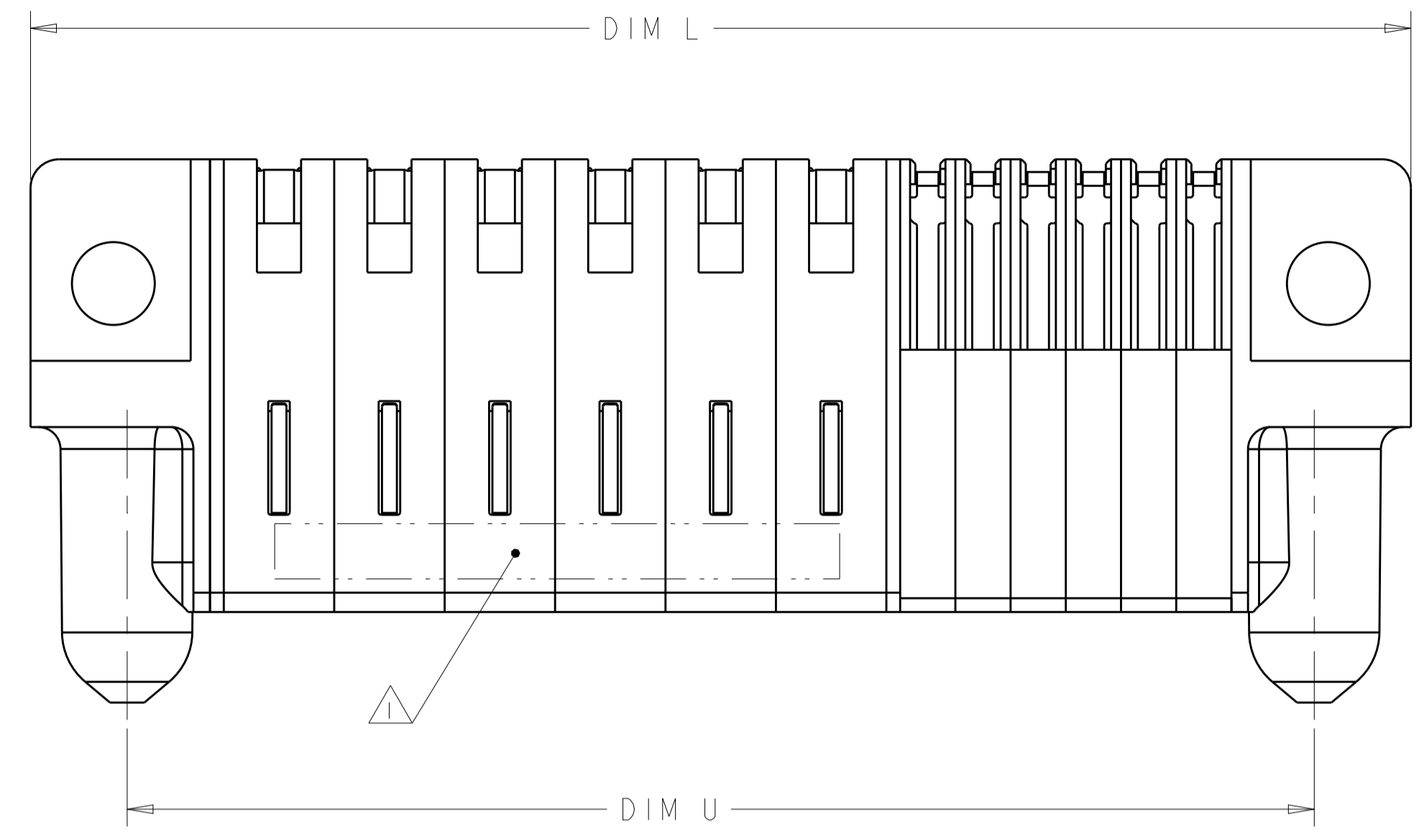

- 1 "AMP", PART NUMBER AND DATE CODE TO BE MARKED
- 2 MATERIAL: HOUSING - GLASS FILLED HIGH TEMP THERMO PLASTIC, UL94 V-O. COLOUR BLACK.
 SIGNAL CONTACT - COPPER ALLOY
 POWER CONTACT - HIGH CONDUCTIVITY COPPER ALLOY
- 3 CONTACT PLATING: NOBLE METAL PLATING ON CONTACT FUNCTIONAL AREA OF POWER AND SIGNAL CONTACTS
- 4 MECHANICAL CONNECTOR KEEP OUT ZONE.
- 5 DATUM AND BASIC DIMENSIONS ESTABLISHED BY CUSTOMER.
- 6 PCB - ALL HOLE DIAMETERS ARE FINISHED HOLE SIZES
- 7 PCB - .0453±.0010 DRILLED HOLES PLATED WITH .0003 MIN Sn OVER .001 TO .003 Cu PLATING TO ACHIEVE A .040 DIAMETER HOLE
- 8 NOT RELEASE FOR PRODUCTION.
- 9 VARIABLE DIMENSIONS SHOWN ON PART VIEW(SHEET 4).

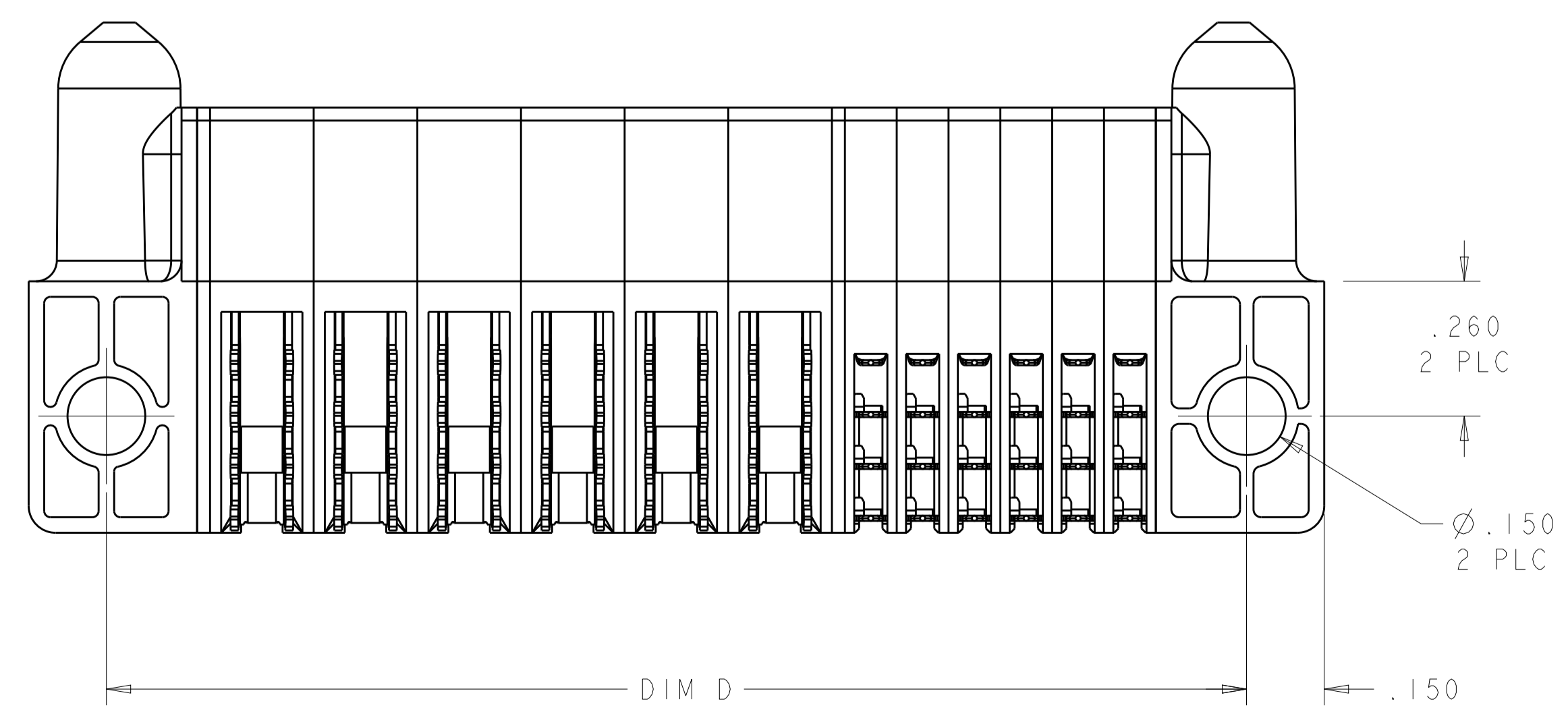
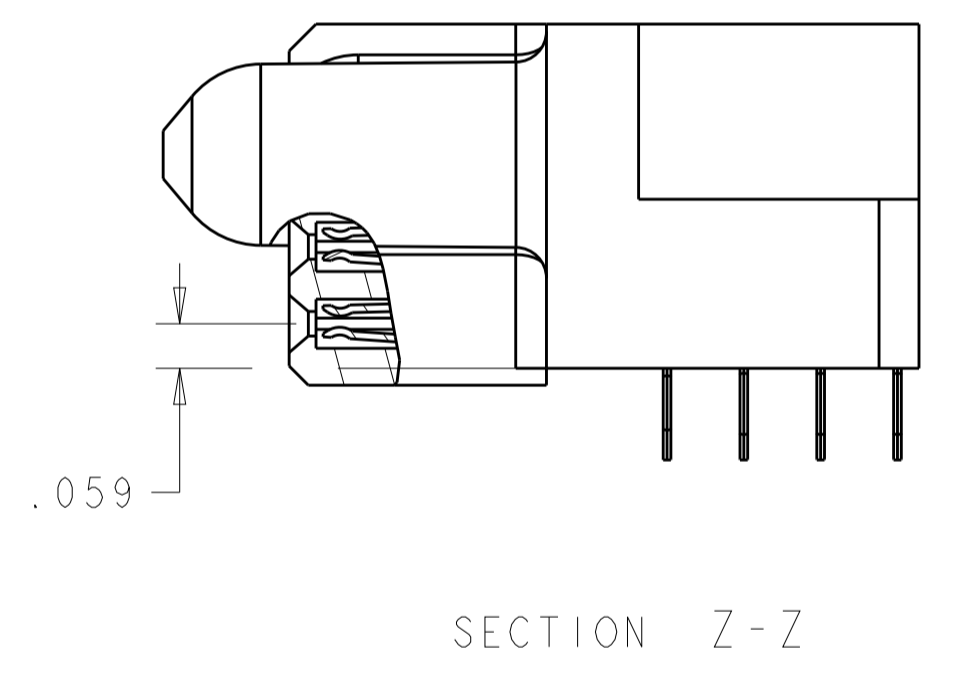
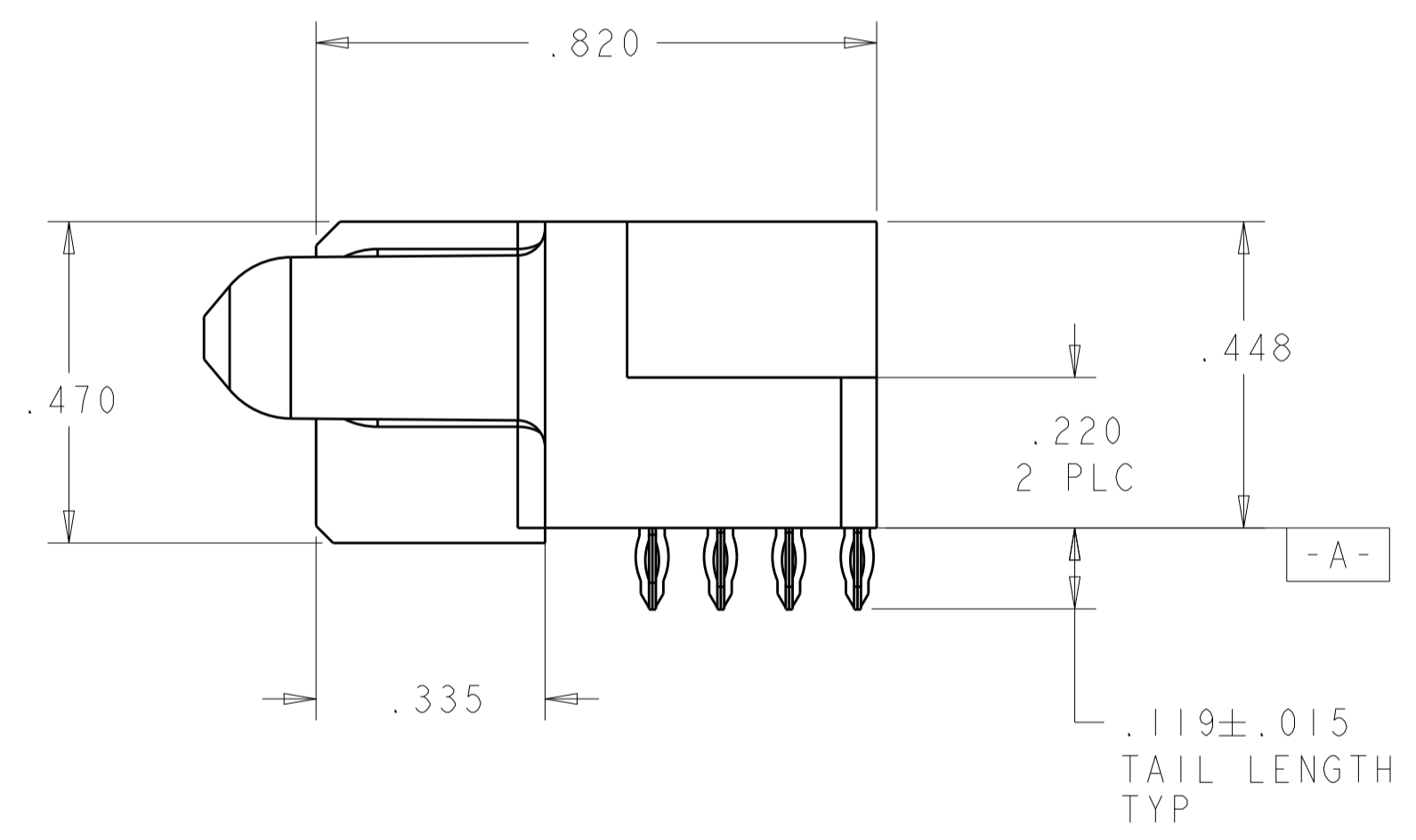
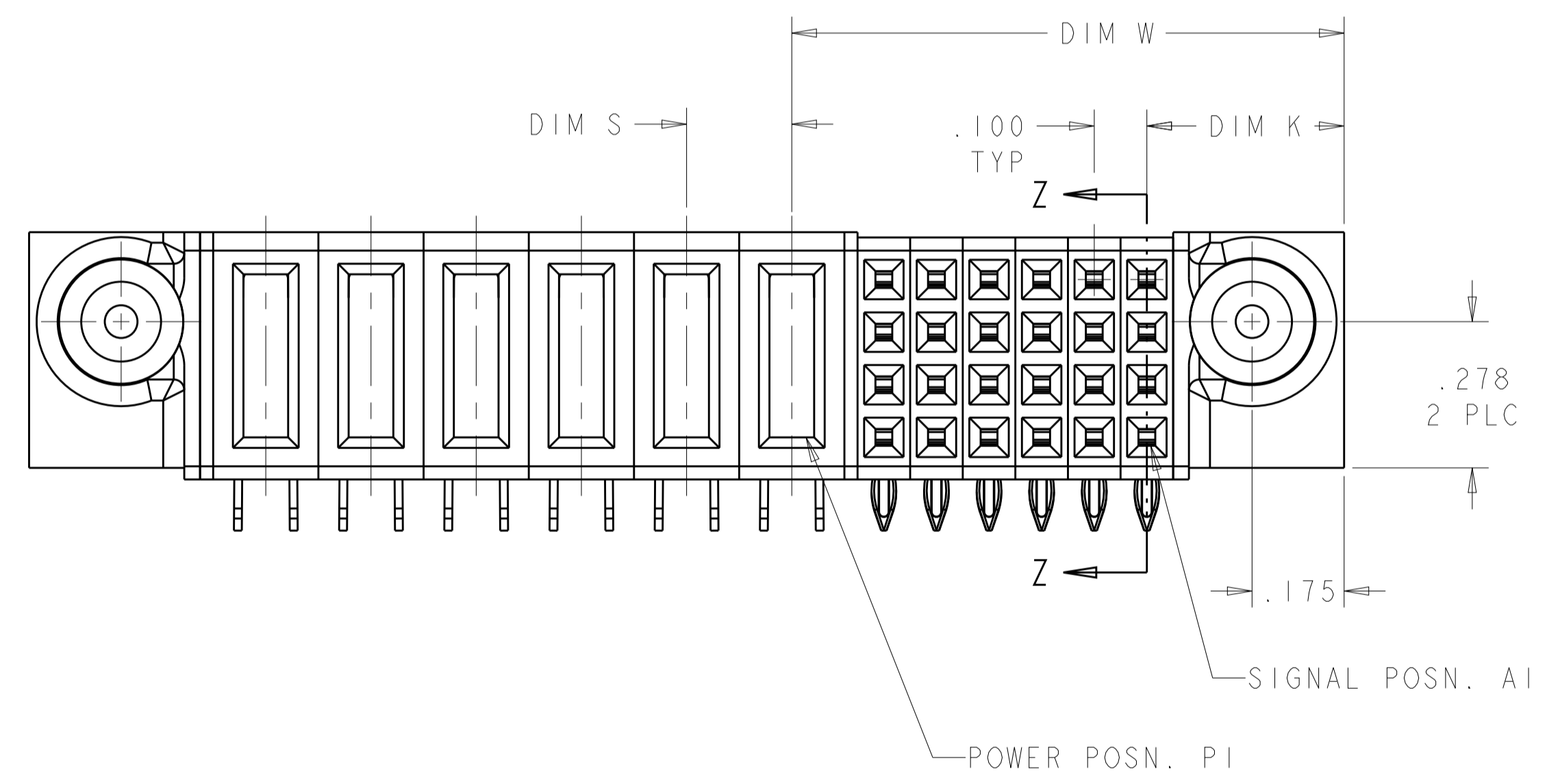

B4	.250	2.45	2.100	2.150	.750	.375	12S + 6P	6450571-5
	.250	2.750	3.400	2.450	1.050	.375	24S + 6P	6450571-4
B5	.200	3.675	3.325	3.375	1.050	.375	24S + 12HDP	6450571-3
	.200	2.950	2.600	2.650	1.075	.400	24S + 8P	6450571-2
	.200	2.500	2.150	2.200	1.050	.375	24S + 6P	6450571-1
	DIM S	DIM L	DIM U	DIM D	DIM W	DIM K	DESCRIPTION	PART NUMBER

THIS DRAWING IS A CONTROLLED DOCUMENT. DWN: R.GRZYBOWSKI 28DEC04
 CHK: M.PERCHEKKE 28DEC04
 APVD: M.PERCHEKKE

DIMENSIONS: INCHES. TOLERANCES UNLESS OTHERWISE SPECIFIED:
 0 PLC ±.01
 1 PLC ±.01
 2 PLC ±.01
 3 PLC ±.005
 4 PLC ±.0020
 ANGLES ±.2

MATERIAL: FINISH: 2 3

THIS DRAWING IS A CONTROLLED DOCUMENT. DWN: R.GRZYBOWSKI 28DEC04
 CHK: M.PERCHEKKE 28DEC04
 APVD: M.PERCHEKKE

NAME: RIGHT ANGLE RECEPTACLE ASSEMBLY PRESS FIT W/GUIDES MULTI-BEAM XL
 PRODUCT SPEC: 108-1973
 APPLICATION SPEC: 114-13038
 WEIGHT: -
 CUSTOMER DRAWING

SCALE: 4:1 SHEET 1 OF 4 REV: B7

LOC	DIST	REV	DATE	BY	APPD
GP	00				
REVISIONS					

PART NUMBER	ROWS	POWER						SIGNAL					
		P6	P5	P4	P3	P2	P1	6	5	4	3	2	1
6450571-1	DCBA	RP	RP	RP	RP	RP	RP	D	D	D	D	D	D
		C	C	C	C	C	C	C	C	C	C	C	C
		B	B	B	B	B	B	B	B	B	B	B	B
		A	A	A	A	A	A	A	A	A	A	A	A
24S + 6P													

PART NUMBER	ROWS	POWER												SIGNAL					
		PI2	PI1	PI0	P9	P8	P7	P6	P5	P4	P3	P2	P1	6	5	4	3	2	1
6450571-3	DCBA	RS	RS	RS	RS	RS	RS	RP	RP	RP	RP	RP	RP	D	D	D	D	D	D
		C	C	C	C	C	C	C	C	C	C	C	C	C	C	C	C	C	C
		B	B	B	B	B	B	B	B	B	B	B	B	B	B	B	B	B	B
		A	A	A	A	A	A	A	A	A	A	A	A	A	A	A	A	A	A
24S + 12HDP																			

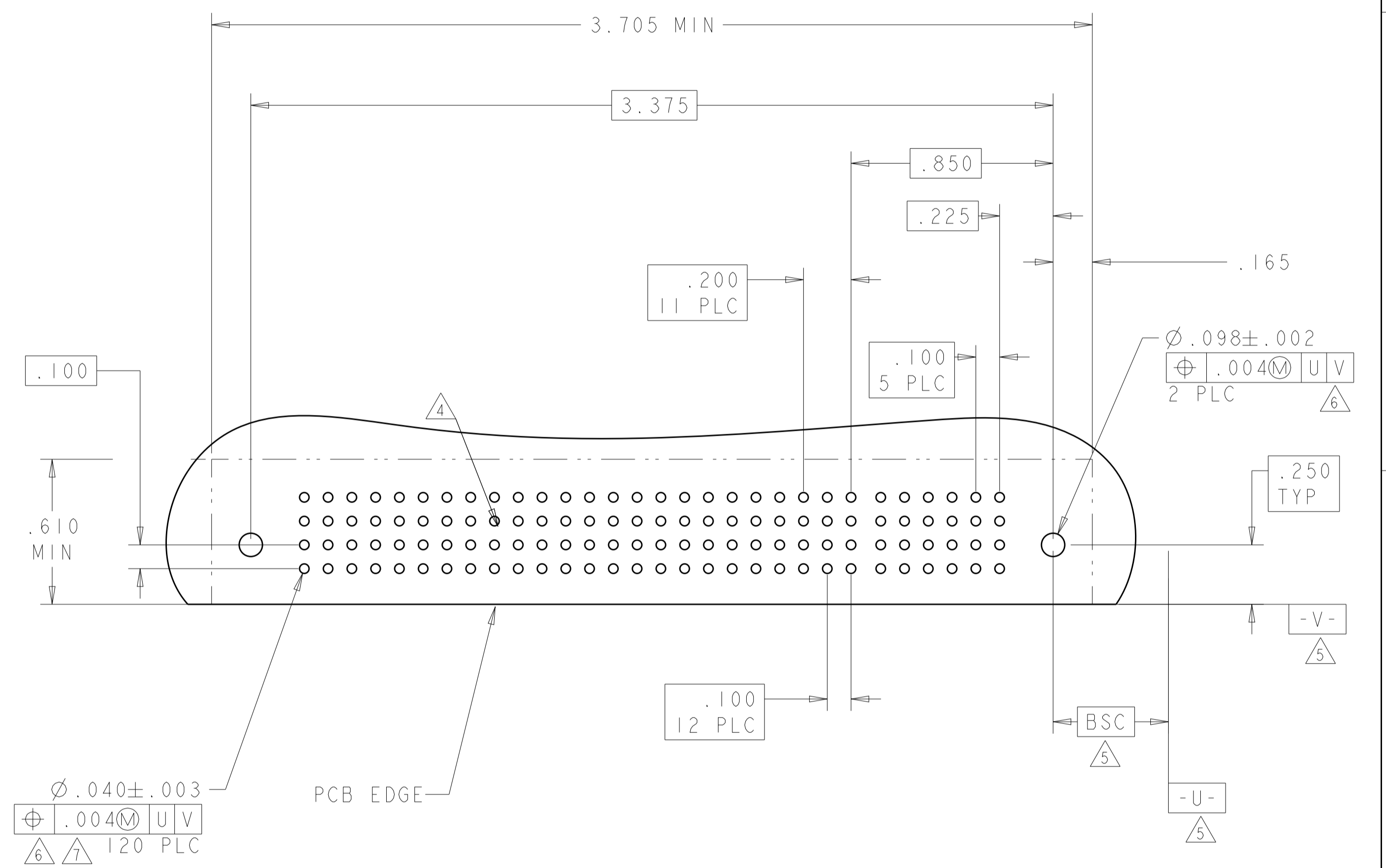
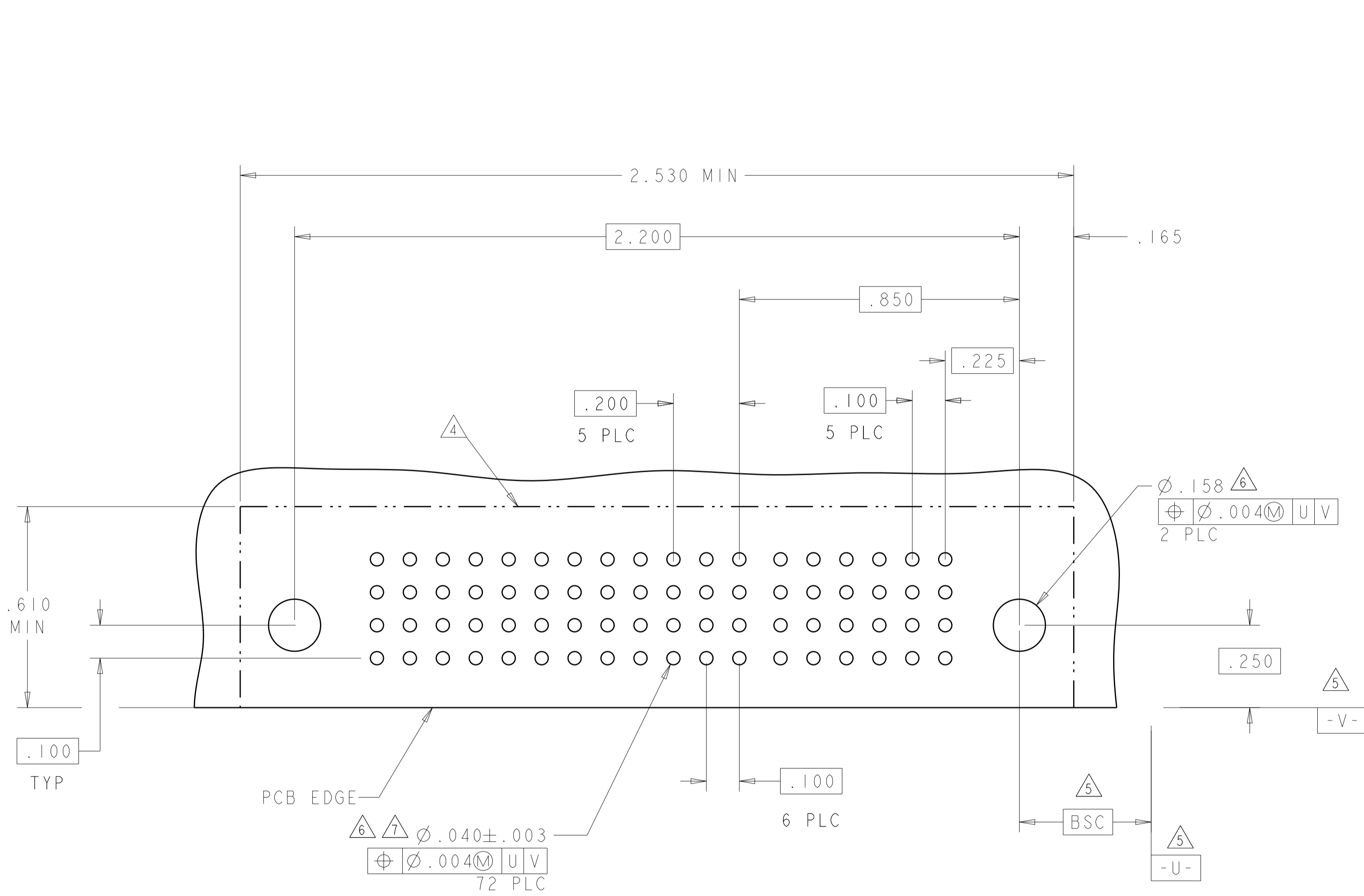

TAIL LENGTH	CODE	DESCRIPTION	ROW
-	HD	HOLD DOWN	-
.165	DD	SIGNAL CONTACT, PRESS-FIT	D
.165	CC	SIGNAL CONTACT, PRESS-FIT	C
.165	BB	SIGNAL CONTACT, PRESS-FIT	B
.165	AA	SIGNAL CONTACT, PRESS-FIT	A
.119	D	SIGNAL CONTACT, PRESS-FIT	D
.119	C	SIGNAL CONTACT, PRESS-FIT	C
.119	B	SIGNAL CONTACT, PRESS-FIT	B
.119	A	SIGNAL CONTACT, PRESS-FIT	A
.165	RL	POWER CONTACT, STD, PRESS FIT	-
.119	RS	POWER CONTACT, STD, PRESS FIT	-
.119	RP	POWER CONTACT, MFBL, PRESS FIT	-

THIS DRAWING IS A CONTROLLED DOCUMENT. DWG: R.GRZYBOWSKI 28DEC04
 CHK: M.PERCHEKKE 28DEC04
 NAME: RIGHT ANGLE RECEPTACLE ASSEMBLY PRESS FIT W/GUIDES MULTI-BEAM XL
 DIMENSIONS: INCHES
 TOLERANCES UNLESS OTHERWISE SPECIFIED:
 0 PLC ±.01
 1 PLC ±.01
 2 PLC ±.01
 3 PLC ±.005
 4 PLC ±.005
 5 PLC ±.0020
 ANGLES ±.020
 FINISH #2
 MATERIAL: -
 WEIGHT: -
 CUSTOMER DRAWING
 SCALE: 4:1
 SHEET: 2 OF 4
 REV: B7

LOC	DIST	REV	DATE	BY	APPV
GP	00				
REVISIONS			DESCRIPTION	DATE	BY
			SEE SHEET 1		

PART NUMBER	ROWS	POWER						SIGNAL					
		P6	P5	P4	P3	P2	P1	6	5	4	3	2	1
6450571-4	D C B A	RL	RL	RL	RL	RL	RL	DD	DD	DD	DD	DD	DD
		RL	RL	RL	RL	RL	RL	CC	CC	CC	CC	CC	CC
		RL	RL	RL	RL	RL	RL	BB	BB	BB	BB	BB	BB
24S + 6P								AA	AA	AA	AA	AA	AA

PART NUMBER	ROWS	POWER						SIGNAL		
		P6	P5	P4	P3	P2	P1	3	2	1
6450571-5	D C B A	RS	RS	RS	RS	RS	RS	D	D	D
		RS	RS	RS	RS	RS	RS	C	C	C
		RS	RS	RS	RS	RS	RS	B	B	B
		RS	RS	RS	RS	RS	RS	A	A	A
12S + 6P										

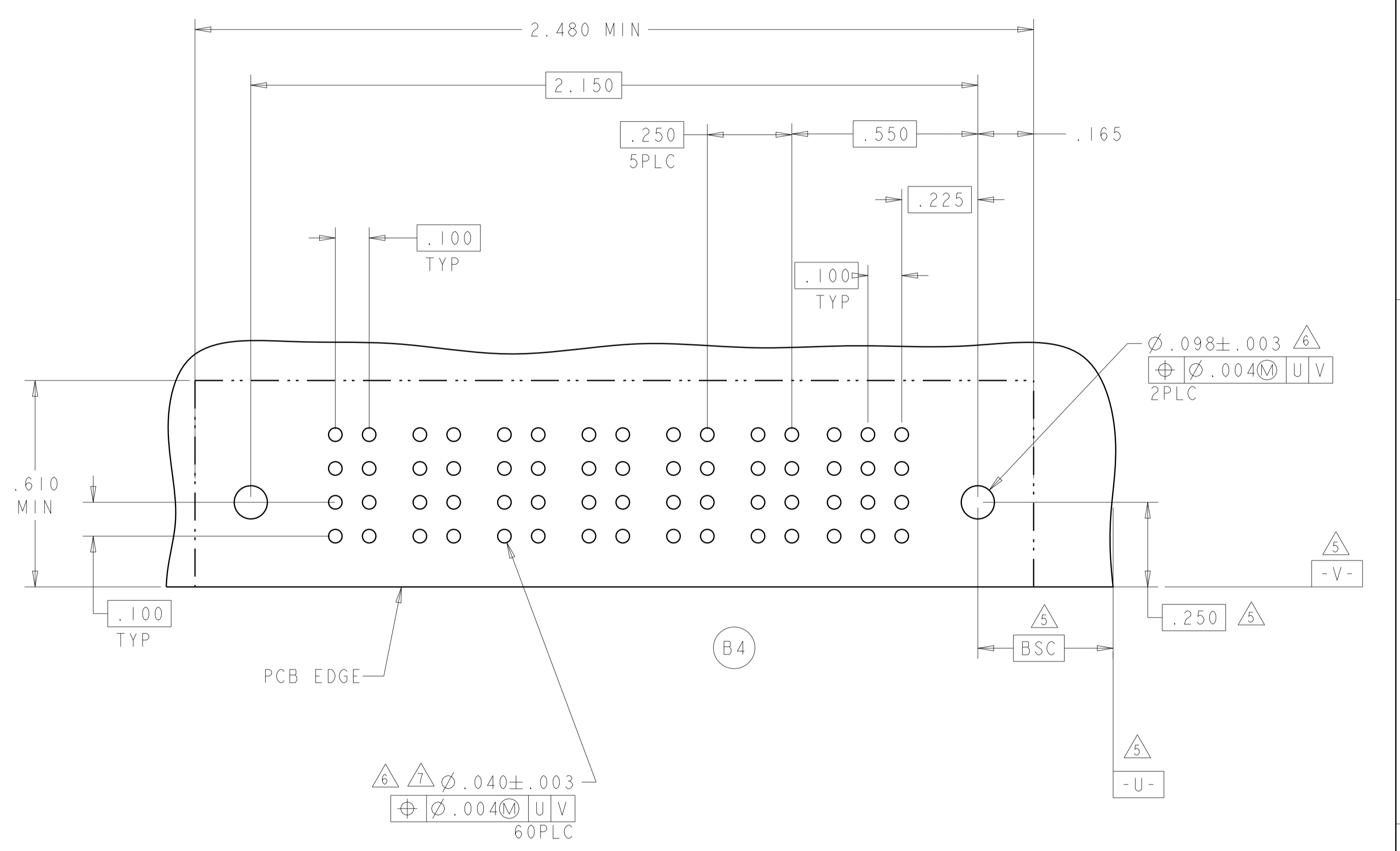
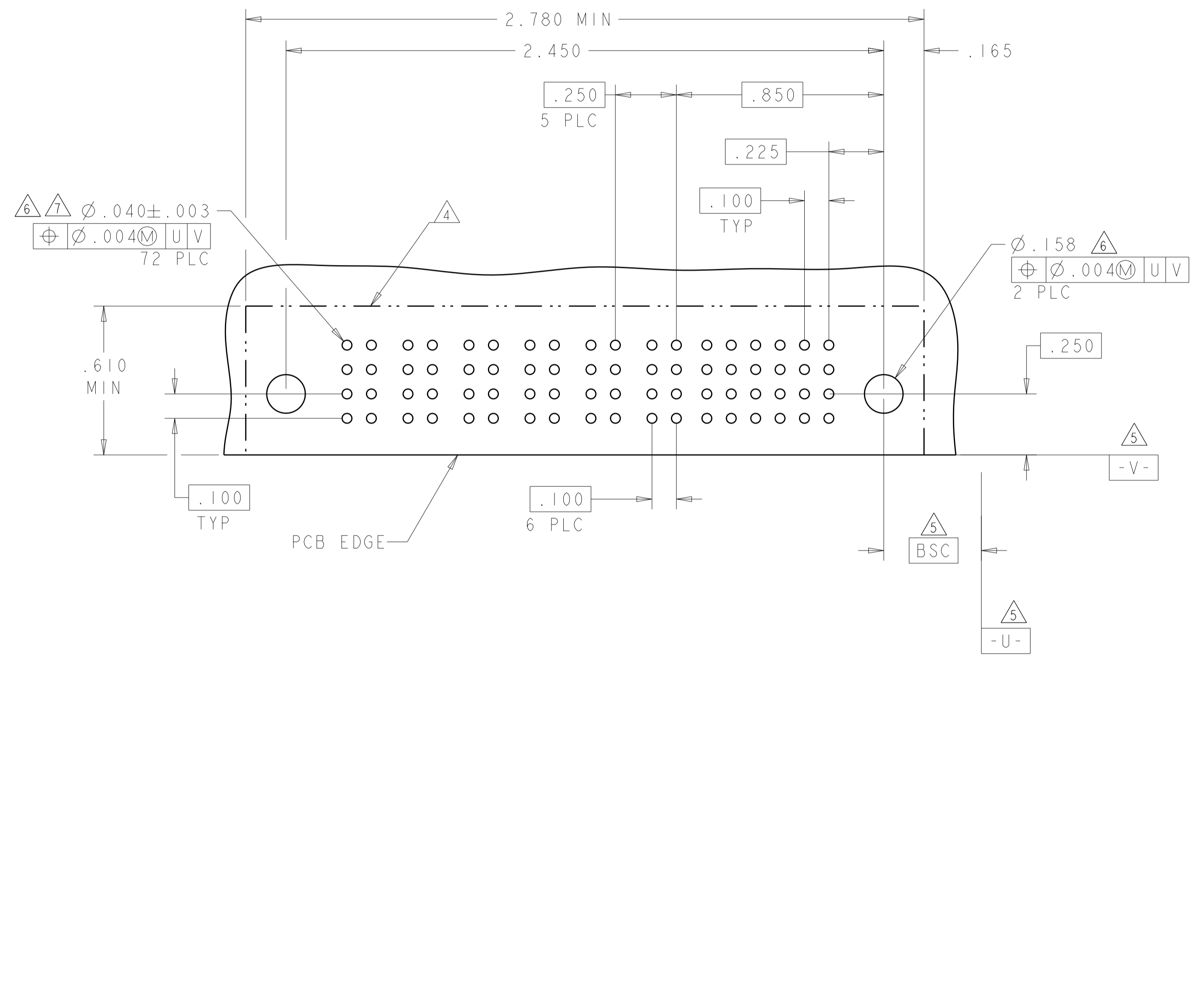

THIS DRAWING IS A CONTROLLED DOCUMENT.

DIMENSIONS:	TOLERANCES UNLESS OTHERWISE SPECIFIED:	OWN: R. GRZYBOWSKI 28DEC04	CHK: M. PERCHERKE 28DEC04
INCHES	0 PLC ± .01 1 PLC ± .01 2 PLC ± .01 3 PLC ± .01 4 PLC ± .005 ANGLES ± .0020	APVD: M. PERCHERKE	NAME: RIGHT ANGLE RECEPTACLE ASSEMBLY PRESS FIT W/GUIDES MULTI-BEAM XL
MATERIAL:	FINISH:	PRODUCT SPEC: 108-1973	APPLICATION SPEC: 114-13038
		WEIGHT:	SIZE: A100779 C=6450571
		CUSTOMER DRAWING	SCALE: 4:1 SHEET 3 OF 4 REV: B7

RESTRICTED TO

LOC	DIST	REVISIONS			
P	LTH	DESCRIPTION	DATE	DWN	APVD
-	-	SEE SHEET 1	-	-	-

PART NUMBER	ROWS	POWER								SIGNAL					
		P8	P7	P6	P5	P4	P3	P2	P1	6	5	4	3	2	1
6450571-2	D C B A	RS	RS	RS	RS	RP	RP	RP	RP	D	D	D	D	D	D
		C	C	C	C	C	C	C	C	C	C	C	C	C	C
		B	B	B	B	B	B	B	B	B	B	B	B	B	B
		A	A	A	A	A	A	A	A	A	A	A	A	A	

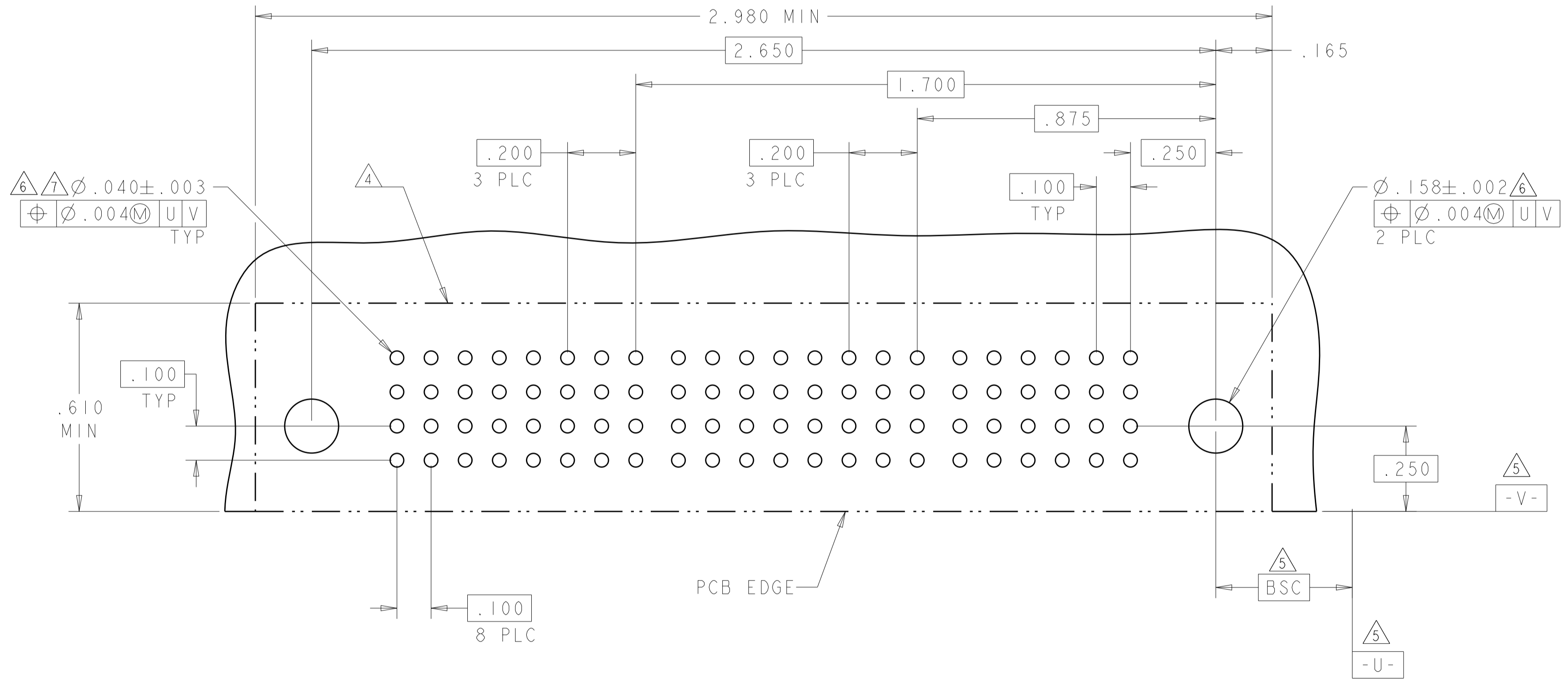
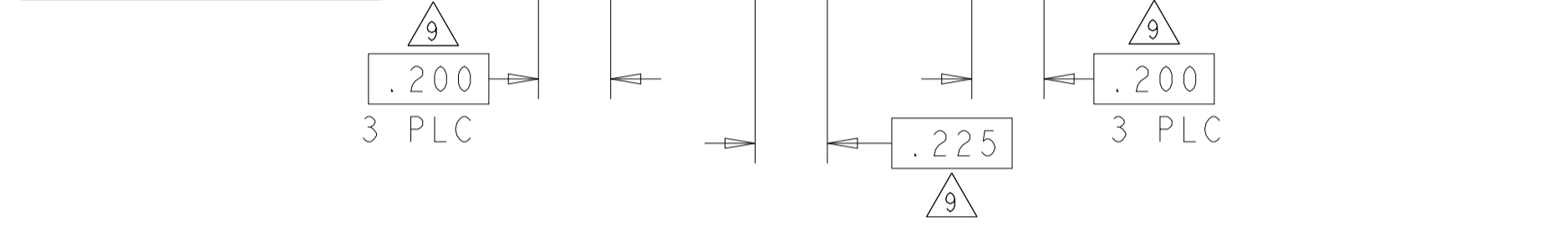

THIS DRAWING IS A CONTROLLED DOCUMENT. DWN: R. GRZYBOWSKI, 28DEC04
 CHK: M. PERCHERKE, 28DEC04

STE TE Connectivity

NAME: RIGHT ANGLE RECEPTACLE ASSEMBLY
 PRESS FIT W/GUIDES
 MULTI-BEAM XL

PRODUCT SPEC: 108-1973
 APPLICATION SPEC: 114-13038

SIZE: A100779 C=6450571
 CAGE CODE: 114-13038

MATERIAL: - FINISH: - WEIGHT: -
 CUSTOMER DRAWING

SCALE: 4:1 SHEET 4 OF 4 REV: B7