

May 1992

Low Voltage Step-Up Converters

Features

- +5V at 40mA From a 1.5V Source
- +5V at 150mA From a 3V Source (See Table 1)
- Guaranteed Start-up at 1.15V
- Standby Mode 80 μ A Quiescent Current
- Low Battery Indication
- Power Ready Function
- Shutdown Feature 5 μ A Max Quiescent
- Pin to Pin Compatible to MAX65X Series
- Efficiency 75% at 1.2V Input

Applications

- Battery Powered Devices
- Single Cell Instruments
- Solar Powered Systems
- Pagers and Radio Controlled Receivers
- Portable Instruments
- 4-20mA Loop Powered Instruments

Ordering Information

PART NUMBER	TEMPERATURE RANGE	PACKAGE
ICL764XCPD	0°C to +70°C	14 Pin Plastic DIP
ICL764XCBD	0°C to +70°C	14 Pin SOIC
ICL764XIPD	-40°C to +85°C	14 Pin Plastic DIP
ICL764XIBD	-40°C to +85°C	14 Pin SOIC

Description

The ICL7644, ICL7645 and ICL7646 are low power fixed +5V output step-up DC-DC converters designed for operation from very low input voltages. All control functions and a power FET are contained in the ICL7644, ICL7645 and ICL7647, minimizing external components. The ICL7646 contains an output pin to drive an external FET when higher output currents are required. A control pin changes between high power and low power standby modes. Standby mode allows operating for extended periods with minimum battery drain, and a power ready function is available for controlling external devices when the device is switched between standby and high power. In high power mode, the output current is approximately 40mA; in standby mode, it is about 500 μ A.

Minimum startup voltage is 1.15V, but once started the device will operate to lower voltages as the battery discharges. A separate low battery monitor is available; it can be used at its default value of 1.17V or may be adjusted by the designer to any higher voltage.

The ICL7644, ICL7646 and ICL7647 are optimized for single cell (1.15V to 1.6V) battery operation and can also be used with input voltages up to 4.0V. The ICL7645 is designed for two cell (or single lithium cell) operation with typical battery voltages of 2.0V to 3.6V. The ICL7647 is identical to the ICL7644 except its output voltage is preset to +3V. The ICL764X series of products also offer a shutdown feature. In the shutdown mode the quiescent current is less than 5 μ A.

Pinouts

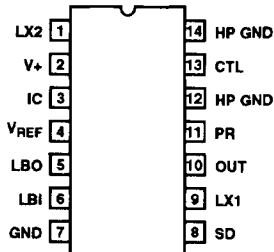
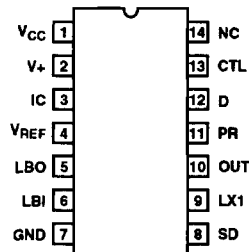
 ICL7644, ICL7645 & ICL7647
 TOP VIEW

 ICL7646
 TOP VIEW

Specifications ICL7644, ICL7645, ICL7646, ICL7647

Absolute Maximum Ratings

Peak Voltage at LX1 Pin	+16V	Storage Temperature	-65°C to +160°C
Peak Voltage at LX2 or V _{CC} Pin	+6.6V	Lead Temperature (Soldering, 10 Sec)	+300°C
Supply Voltage to L1	+15V	Power Dissipation:	
Supply Voltage to L2, V _{CC}	+5.6V	Plastic DIP (Derate 10mW/°C above +70°C)	800mW
Peak Current, LX150mA	SOIC (Derate 8.7mW/°C above +70°C)	695mW
Peak Current, LX2	1.6A	NOTE: V* is generated at LX1. In low current mode, it is 4.5V to 5.6V	
LBO Output Current50mA	(2.6V to 3.6V on ICL7646); in high current mode, it is 10V to	
Input Voltage, CTL, LBI (See Note)	-0.3V to (V* +0.3V)	15V.	

CAUTION: Stresses above those listed in "Absolute Maximum Ratings" may cause permanent damage to the device. This is a stress only rating and operation of the device at these or any other conditions above those indicated in the operational sections of this specification is not implied.

Operating Conditions

Operating Temperature Range:	
ICL764XCXX	0°C to +70°C
ICL764XIXX	-40°C to +85°C

Electrical Specifications ICL7644, ICL7646, ICL7647 (GND = 0V, V_{BATT} = 1.2V, T_A = 25°C, Unless Otherwise Specified.)

PARAMETERS	SYMBOL	TEST CONDITIONS	LIMITS			UNITS
			MIN	TYP	MAX	
Output Voltage	V _{OUT}	ICL7644, ICL7646 T _A = Over Temp.*	4.5	5.0	5.5	V
		ICL7647 T _A = Over Temp.*	2.7	3.0	3.3	V
Minimum Input Voltage to LX1	V _{LX1}	I _L = 0μA (Note 1)	-	0.9	1.0	V
Minimum Startup Voltage to LX1	V _{LX1}	I _L = 0μA	-	0.9	1.15	V
Input Voltage to LX2	V _{LX2}		0.5	-	5.6	V
Peak LX2 Switch Current	I _{LX2}	ICL7644, ICL7647 (Note 1)	-	-	1.5	A
Standby Current	I _O	I _L = 0μA, CTL = Open	-	80	-	μA
Switching Frequency	f _O	V _{BATT} = 1.0 to 1.6V	15.5	18	24	kHz
LX2, D Switch Duty Cycle	%ON	ICL7644, ICL7646	66	75	80	%
		ICL7647	50	66	75	%
LX2, D Switch On Time	t _{ON}	ICL7644, ICL7646	27	42	49	μs
		ICL7647	20	37	47	μs
LX2 On Resistance	R _{DSON}	ICL7646, ICL7647 (Note 1)	0.40	-	0.67	Ω
D Output Saturation Current		ICL7646, Source Sink (Short Circuit Current)	-	-25	-	mA
			-	100	-	mA
Low Battery Input Threshold Voltage	V _{LBI}		1.12	-	1.18	V
Low Battery Input Threshold Tempco			-	-0.5	-	mV/°C
Low Battery Input Bias Current	I _{LBI}		-	0.01	10	nA
Low Battery Output	V _{LBO}	V _{LBI} < 1.12V, I _{LBO} = 1.6mA	-	-	0.4	V
		V _{LBI} > 1.18V, I _{LBO} = -1μA	V*-1	-	-	V
Power Ready	V _{PR}	PR High, I _{PR} = -1μA	-	V _{OUT} -0.2	-	V
		PR Low, I _{PR} = 1μA	-	0.3	-	V
CTL Input Threshold	V _{CTL}		-	0.07	-	V
Efficiency		5mA ≤ I _{LOAD} ≤ 40mA	-	75	-	%

NOTE:

1. Not tested, guaranteed by design and characterization.

* Commercial Temperature Range = 0°C to +70°C

Industrial Temperature Range = -40°C to +85°C

Specifications ICL7644, ICL7645, ICL7646, ICL7647

Electrical Specifications ICL7645 (GND = 0V, $V_{BATT} = 2.4V$, $T_A = +25^\circ C$, Unless Otherwise Specified.)

PARAMETERS	SYMBOL	TEST CONDITIONS	LIMITS			UNITS
			MIN	TYP	MAX	
Output Voltage	V_{OUT}	$T_A = \text{Over Temperature}^*$	4.5	5.0	5.5	V
Minimum Input Voltage to LX1	V_{LX1}	$I_L = 0\mu A$	-	0.9	1.0	V
Minimum Startup Voltage to LX1	V_{LX1}	$I_L = 0\mu A$ (Note 1)	-	0.8	1.15	V
Input Voltage to LX2	V_{LX2}		-	-	5.6	V
Peak LX2 Switch Current	I_{LX2}	(Note 1)	-	-	1.5	A
Standby Current	I_Q	$I_L = 0\mu A$, CTL = Open	-	40	-	μA
Switching Frequency	f_O	$V_{BATT} = 2.0$ to $3.2V$	15.5	18	24	kHz
Switch Duty Cycle	%ON		40	50	60	%
Switch On Time	t_{ON}		15	28	38	μs
LX2 On Resistance	R_{DSON}	(Note 1)	0.40	-	0.67	Ω
Low Battery Input Threshold Voltage	V_{LBI}		1.12	-	1.18	V
Low Battery Input Threshold Tempco			-	-0.5	-	mV/ $^\circ C$
Low Battery Input Bias Current	I_{LBI}		-	0.01	10	nA
Low Battery Output	V_{LBO}	$V_{LBI} < 1.12V$, $I_{LBO} = 1.6mA$	-	-	0.4	V
		$V_{LBI} > 1.18V$, $I_{LBO} = -1\mu A$	V^*-1	-	-	V
Power Ready	V_{PR}	PR High, $I_{PR} = -1\mu A$	-	$V_{OUT} - 0.2$	-	V
		PR Low, $I_{PR} = 1mA$	-	0.3	-	V
Input Threshold	V_{CTL}		-	0.7	-	V
Efficiency		$5mA \leq I_{LOAD} \leq 150mA$	-	75	-	%

NOTE:

1. Not tested, guaranteed by design and characterization.

* Commercial Temperature Range = $0^\circ C$ to $+70^\circ C$

Industrial Temperature Range = $-40^\circ C$ to $+85^\circ C$

Functional Block Diagram

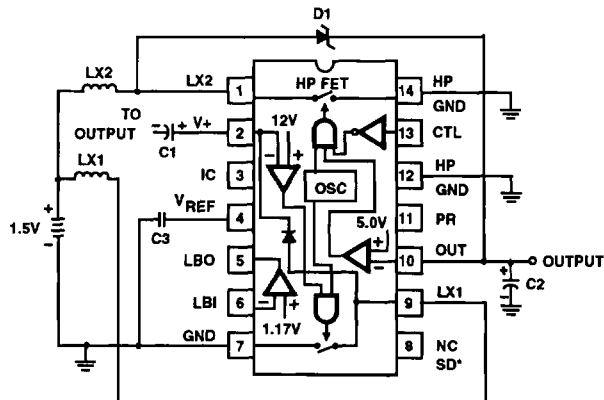

ICL7644, ICL7645, ICL7646, ICL7647

Pin Description

PIN NUMBER		SYMBOL	FUNCTION
ICL7646	ICL7644, ICL7645, ICL7647		
-	1	LX2	Output drain of high power N-channel MOSFET.
1	-	V _{CC}	Connect to battery positive terminal.
-	2	V+	Output of low power up converter; 10 to 15V in high power mode. 4.5V to 5.5V in standby mode.
2	-	V+	Output of low power up converter. 10 to 15V in high power mode. 2.8 to 3.6V in standby mode.
3	3	I/C	Internal Connection. Leave this pin unconnected. "Do not ground."
-	7	GND	Low power ground.
4	4	V _{REF}	1.295V bandgap reference output; should be decoupled with a capacitor to pin 7. This terminal is high impedance and cannot source or sink current.
5	5	LBO	Low battery monitor output. Sinks 1.6mA when LBI is less than 1.17V, otherwise sources 1µA from V+.
6	6	LBI	Low battery monitor input. Very high input impedance.
8*, 14	8*	NC *SD	*Shutdown pin. Allows user to turn part off by grounding pin 8.
9	9	LX1	Output (drain) of low power N-channel power driver.
10	10	OUT	+5V (+3V on ICL7647). Feedback (input) pin for high power operation; output pin in standby mode.
11	11	PR	Power ready output; high (+5V on ICL7644, 7645, 7646; +3V on ICL7647) when high power converter is ready to supply power.
7	12, 14	HP, GND	High power ground.
13	13	CTL	Control mode switch input; open circuit or high for standby mode, ground for high power mode.
12	-	D	Driver output to external FET. Output voltage swings from GND to V _{OUT} .

Low Voltage Step-Up Converters

Operating Principle

The ICL7644, ICL7645, ICL7646 and ICL7647 are flyback, or boost converters: energy from the battery is first stored in a coil and then discharged to the load. Essentially, the circuit consists of a battery in series with a coil, a high power FET, rectifier, and filter, as shown in Figure 1. When the switch is closed, current builds up in the coil, creating a magnetic field. During the second half, or flyback part of the cycle, the power FET opens, the magnetic field collapses and the voltage across the inductor reverses polarity, adding to the voltage of the battery and discharging through the rectifier into the load.

The switch is controlled by a constant frequency oscillator whose output is gated on and off by a comparator that moni-

tors the output voltage. When the output voltage is above the comparator threshold, the power FET skips an entire cycle of the oscillator. This pulse skipping technique varies the average duty cycle to achieve regulation, rather than varying the period or duty cycle of each cycle of the power FET; it eliminates a number of linear circuits that would otherwise add both circuit complexity and quiescent operating current. The key to operating CMOS circuitry from a 1V supply depends on a technique called bootstrapping. A specially designed oscillator starts itself up on a very low voltage and builds up (or bootstraps) a higher voltage that in turn is used as the supply for further operation. This supply yields higher efficiency because the bootstrapped voltage drives the gate of the internal power FET transistor to lower on resistance.

ICL7644, ICL7645, ICL7646, ICL7647

When power is first applied, the circuit is very inefficient (for the first cycle) until a higher voltage is generated on the fly-back half of the first cycle. This higher voltage is rectified and filtered, and powers the whole IC (and thus the oscillator) for the next cycle. Since each cycle generates a higher voltage for the next cycle, the voltage builds up very rapidly. An internal regulator limits the voltage to about 12V. The load for this supply is only the CMOS chip itself, so the requirements for the components, particularly the external inductor L1, are very broad. This voltage is brought out to the V+ pin and is connected to a tantalum capacitor for filtering.

This bootstrapped 12V drives an internal N-channel power FET that furnishes the switching power for the load. Since the gate of this FET is driven from a 12V supply, it has a very low on resistance and can efficiently switch high currents through a second inductor, L2. It is the power stored in this second inductor that is delivered to the 5V load via an external Schottky diode. The rectified and filtered 5V output is connected back to the OUT pin to provide feedback. The ICL7644/7645/7646/7647 thus has two separate switching circuits and uses two separate inductors.

Circuit Details

A typical application circuit is shown in Figure 2. The higher value inductor, L1, is typically 4.7mH, and may have fairly high losses. It is used for the low power section of the circuit and is rectified by an internal diode and routed to pin 2, V+, where it is filtered by an external capacitor, C1. The second inductor, L2, varies from 39 μ H to 500 μ H, depending on input voltage and load current. It must have low series resistance and sufficient core material to handle the load power without saturating. The inductor is connected to pin 1 (LX2), the drain of the Low Power FET, and is rectified by an external Schottky diode, D1, and filtered by an external capacitor, C2. This is the main +5V output (+3V on the ICL7647), and it is connected to OUT, pin 10, which is the feedback input in high power mode. Figure 3 shows a similar circuit for the ICL7646 using an external FET for higher power output.

Low Power Standby Mode

A control pin (CTL) is available for putting the device into standby mode to conserve power. When this pin is held low, the IC operates in the high power mode, if it is driven high or left open the following occurs: the POWER READY (PR) pin is driven low, the high power FET is gated off, the 12V (V+) switching supply is reduced to 5V (+3V on the ICL7647) and is connected to the V_{OUT} pin.

By lowering the internal 12V supply to 5V, the leakage currents of the CMOS circuits and the losses associated with its voltage reference and oscillator are reduced to a minimum. The internal low power 5V supply can furnish up to 500 μ A, and it is connected to the normal 5V output pin (OUT) to supply current to the load, keeping alive standby circuits.

Power Ready Output Pin

During initial start up (and when placed in standby mode), the ICL7644/7645/7646/7647 internal voltages are too low to drive the power FET efficiently. A separate comparator determines when this voltage has reached a high enough value to drive the FET. The output of this comparator gates the FET drive voltage. This scheme extends battery life in standby mode and prevents the power FET from stalling when switching to high power mode. The comparator output is also brought out to the POWER READY (PR) pin and can be used to control external circuits, further reducing battery drain.

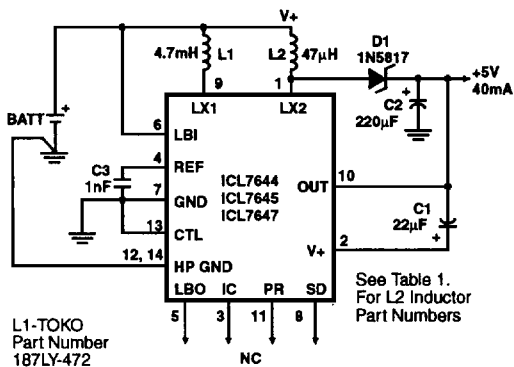

FIGURE 2. ICL764X TYPICAL APPLICATION

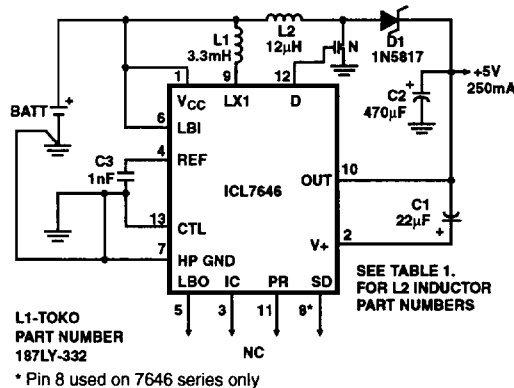

FIGURE 3. ICL7646 TYPICAL APPLICATION

Start Up and Mode Considerations

The ICL7644/7645/7646/7647 may be started up in either the low power (standby) or high power mode. When starting in the high power mode, both the low power switch and the high power switch start immediately. Whether or not the load is connected, the output voltage will rise to 5V in the first few cycles. The OUT pin becomes an input for feedback to control regulation.

If the high power load (greater than about 500µA) is connected to the OUT pin and the device is placed in the low power mode (CTL pin driven high or left open), the low power oscillator will have to furnish all of the 5V power via the OUT pin, and the low power oscillator will stall. **It is, therefore, important to disconnect any load currents (greater than 500µA) whenever the low power or standby mode is selected.** The POWER READY (PR) pin may be used to disconnect the load via an external transistor. This way the mode and connection of the high power load are both controlled through the CTL input.

Input Filtering

It is important to limit the rate of rise of the battery voltage when the circuit is first turned on with a mechanical switch or the installation of the battery(ies). A simple R-C network made up of the battery internal resistance and a 10µF tantalum capacitor placed at the battery side of L2 input is sufficient for this purpose. This capacitor also helps to absorb the (relatively) high peak currents that are drawn from the battery in the high power mode.

Output Filtering

It is also important to limit the speed at which V+ decreases to 5V when the mode is switched from high power to standby. This is accomplished by putting a 22µF capacitor between the V+ and OUT pins. Also, a 220µF capacitor placed on the OUT pin provides both filtering and serves to hold up the 5V during the switchover period. Without these capacitors, the 5V may spike negatively during the switchover.

Low Battery Function

A completely independent low battery monitor is built into the ICL764X series. Its input (LBI) is the + input of a CMOS comparator whose - input is connected to the internal 1.17V band-gap reference. This input can be connected directly to the battery in single cell circuits or connected to a high resistance voltage divider for higher voltage monitoring. The output (LBO) can sink 1.6mA or source several microamperes from V+.

Shutdown Function

The ICL764X series is equipped with a shutdown feature. Pin 8 is used to power the part down. During shutdown the part draws less than 5µA quiescent current. The part can be shutdown by grounding pin 8.

Inductor Selection

Low Power Coil

The choice of the low power inductor, L1, is not critical. A 4.7mH coil with a DC resistance of less than 40Ω is adequate for most applications. In general, higher inductance values allow lower start up voltages, while lower resistances yield lower quiescent

current in standby mode. If the inductance is made too high, the low power (V+) output voltage and current are reduced. This in turn reduces the efficiency of the power section, so the +5V output (in standby mode) supplied less current. Lower values of inductance raise the minimum start up voltage.

High Power Coil

The high power coil, L2, must store most of the energy that flows into the load. Accordingly, it should have a powdered iron or ferrite core and should have low resistance to minimize losses. It also must have an adequate current rating to prevent saturation.

Calculating the worst case inductor for the high power section (LX2) of the ICL7644/7645/7646/7647 is a two step process:

1. Determine the smallest inductor value that will not cause the circuit to exceed the peak current rating of the ICL7644/7645/7647 with the highest expected input voltage (VINMAX), the longest on time (tONMAX), and the lowest total resistance (R(MIN)). R(MIN) is the sum of the minimum coil and FET resistances. Note that this peak current relates to the inductor and the FET switch and is several times the load current.

The following example assumes the minimum frequency fO(MIN) and the maximum % ON(MAX) for the calculation of tON(MAX). Although the calculated value for tON(MAX) is above that specified in the electrical characteristics table (49µs), the illustration is still a valid one that yields a worst case minimum inductor value.

NOTE: Units with both fO(MIN) and %ON(MAX) values near the ends of the allowed distributions will be rejected for tON(MAX).

From the Electrical Characteristics table:

- IPK LX2 = 1.5A
- RDSON(MIN) = 0.4Ω
- fO(MIN) = 15.500Hz
- Duty Cycle Maximum, %ON(MAX) = 0.8

then:

$$t_{ON(MAX)} = \%ON_{(MAX)} / f_{O(MIN)} = 0.8 / 15500 = 51.6\mu s$$

Assume that the minimum coil resistance, RCOIL(MIN) is:

$$R_{COIL(MIN)} = 0.1\Omega$$

The minimum total resistance, R(MIN) is:

$$R_{(MIN)} = R_{DSON(MIN)} + R_{COIL(MIN)} = 0.4 + 0.1 = 0.5\Omega$$

then:

$$I_{PK} = 1.5A = \frac{V_{IN(MAX)}}{R_{(MIN)}} \times \left[\frac{-R_{(MIN)} \times t_{ON(MAX)} / L_{(MIN)}}{1 - e^{-R_{(MIN)} \times t_{ON(MAX)} / L_{(MIN)}}} \right]$$

or:

$$L_{(MIN)} (\mu H) = \frac{-R_{(MIN)} t_{ON(MAX)}}{\ln \left[(1 - R_{(MIN)} \times I_{PK} / V_{IN(MAX)}) \right]}$$

For a maximum input voltage of 1.56V (single alkaline cell), and a minimum coil resistance of 0.1Ω, the minimum permissible inductance for the ICL7644/7645/7647 is 39.37µH.

2. Having determined the minimum inductance ($L_{(MIN)}$) that keeps the peak current below the individual component ratings, we next calculate a new peak current (I'_{PK}) using the highest resistance ($R_{(MAX)}$), the lowest input voltage ($V_{IN(MIN)}$) and the shortest on time ($t_{ON(MIN)}$). Using these parameters, we will calculate the minimum available output (DC) current.

From the Electrical Characteristics table:

$$R_{DSON(MAX)} = 0.67\Omega$$

$$f_{O(MAX)} = 24\text{kHz}$$

$$\text{Duty Cycle Minimum, } \%ON_{(MIN)} = 0.66$$

then:

$$t_{ON(MIN)} = \%ON_{(MIN)} / f_{O(MAX)} = 0.66 / 24000 = 27.5\mu\text{s}$$

Assume that the maximum coil resistance, $R_{COIL(MAX)}$ is:

$$R_{COIL(MAX)} = 0.15\Omega$$

The maximum total charging resistance, $R_{(MAX)}$ is:

$$R_{(MAX)} = R_{DSON(MAX)} + R_{COIL(MAX)} = 0.82\Omega$$

At the end of the ON period:

$$I'_{PK} = \frac{V_{IN(MAX)}}{R_{(MAX)}} \times 1 - e^{-R_{(MAX)} \times t_{ON(MIN)} / L_{(MIN)}}$$

The energy stored in the coil is:

$$E_{COIL} = \frac{L_{(MIN)} \times I'_{PK}{}^2}{2}$$

And the power put into the coil is:

$$P_{COIL} = f_{O(MAX)} \times E_{COIL} \\ = \frac{L_{(MIN)} \times I'_{PK}{}^2 \times f_{O(MAX)}}{2}$$

The minimum DC output current, I_{OUT} , is:

$$I_{OUT(MIN)} = \frac{P_{LOAD}}{V_{LOAD}} = \frac{P_{COIL} - P_{LOSS}}{V_{OUT(MAX)} + V_{DIODE} - V_{IN(MIN)}} = \frac{P_{COIL} - I'_{PK}{}^2 \times (R_{COIL(MAX)} / 3) \times (1 - \%ON_{(MIN)})}{V_{OUT(MAX)} + V_{DIODE} - V_{IN(MIN)}}$$

Using a $47 \pm 10\%$ μH coil with a resistance of 0.15Ω , an input voltage of 1.1V , and the worst case highest output voltage of 5.5V . The calculated minimum DC output current is 32mA . This assumes a 0.3V forward drop in the 1N5818 diode.

When selecting a coil, care should be exercised to insure that the minimum inductance value, including all the manufacturing tolerances, is never lower than the calculated inductance, or the peak current rating of LX2 may be exceeded. In addition, the current rating of the coil should be greater than the peak current used in the calculation (1.5A , normally), to avoid saturating the core.

If the worst case output current is too small, then either the minimum input voltage must be increased or the maximum input voltage should be decreased. It is always desirable to decrease the ratio between maximum and minimum input voltages. The coil resistance also has a significant effect on the output current, so selecting a lower coil resistance will increase the output current and increase the overall efficiency.

If no satisfactory value of inductance can be found for the desired current, the ICL7646 may be used with an external FET whose peak current exceeds 1.5A . The calculations are similar for the ICL7644 except the external FETs R_{DSON} and current rating should be substituted in the above equations.

If the worst case output current is significantly higher than the required load current, a higher inductance value may be used. This will tend to reduce the peak current and the ripple voltage. Be sure to adjust the coil resistance and recalculate all the values.

When the maximum battery voltage exceeds 1.65V , the ICL7645 should be used. Calculations for the ICL7645 are identical to the ICL7644 calculations, except that different values must be used for the maximum and minimum duty cycles.

In general, if a choice of batteries is available, higher input voltages are preferred for two reasons. First, as the input voltage approaches 1V , the load on the battery increases while the losses increase. The losses become so dominant that efficiency suffers and little output current can be maintained. Second, certain losses, such as the coil resistance and the FET on resistance are less significant with higher input voltages. This means not only higher efficiency, but a greater range of input voltages are tolerable; this in turn means that more of the chemical energy can be converted into electricity. For example, three NiCd cells, with a fully charged voltage of 4.05V , may still be used down to 1.1V (with about 5mA of 5V output current), far beyond the normal life expectancy.

The inductance values for commonly encountered battery operated power supplies are tabulated in Table 1.

ICL7644, ICL7645, ICL7646, ICL7647

TABLE 1. MINIMUM INDUCTANCE FOR COMMON BATTERIES

BATTERY TYPE	BATTERY VOLTAGE		OUTPUT		COIL SPECIFICATIONS (L2) TOKO 8RBS 262LYF SERIES		
	MIN	MAX			μH*	OHMS	PART NO.
1 NiCads (ICL7644)	1.15V	1.35V	5V	43mA	39	0.09	-0087K
1 Alkaline (ICL7644)	1.20V	1.55V	5V	43mA	47	0.10	-0088K
2 Alkaline (ICL7644)	2.5V	3.5V	5V	150mA	33	0.80	-0086K
2 NiCads (ICL7645)	2.30V	2.70V	5V	64mA	68	0.16	-0090K
2 Alkalines (ICL7645)	2.40V	3.10V	5V	62mA	82	0.17	-0091K
1 Lithium (ICL7645)	2.60V	3.60V	5V	64mA	100	0.22	-0092K
1 NiCad (ICL7646)**	1.15V	1.35V	5V	250mA	12	0.049	-0081K
1 Alkaline (ICL7646)**	1.20V	1.55V	5V	275mA	6.8	0.037	-0079M
1 Alkaline (ICL7647)	1.20V	1.55V	3V	60mA	39	0.09	-0087K

* Coils are from Toko. Inductance (μH) is the MINIMUM allowed for the listed battery voltage range (Battery Voltage: MIN, MAX). Lower values are not recommended, except when using the 7646 converters since they use an external MOSFET. If less current than listed in the Output column is needed, a higher inductance coil will reduce losses. The optimum inductance varies inversely with required output current if all other conditions are unchanged.

** These ICL7646 circuits use an external current switch. Peak switch current is typically 3.5A.

Capacitor Selection

The high current fast rise-time pulses associated with switching power supplies demand good grounding and bypassing techniques. The ICL7644/7645/7647 have 3 ground pins to improve grounding. In addition, the internal voltage reference is brought out for connection to an external 1nF capacitor, minimizing noise and modulation on the reference.

The two output voltages, V+ and +5V should be filtered with tantalum capacitors, or other capacitors with low effective series resistance, to minimize transients. If aluminum electrolytic capacitors are used, they should be paralleled with 0.1μF disc ceramics.

Selecting Low Power Switching Diodes

The ICL7644/7645/7646/7647 use one external diode, and this diode must be a Schottky. A common Schottky type that performs well is the 1N5818.

In applications where standby current must be minimized, the diode's reverse leakage characteristics are especially important. The ICL7644/7646/7647 (40μA for the ICL7645) standby current is typically 80μA, while the reverse current of some Schottky rectifiers can exceed this value, particularly at high temperature. If necessary, diode leakage can be reduced with higher voltage Schottky types such as 1N5817. If standby mode is not used or is used only for short periods, then diode leakage is not a significant additional loss compared to the normal load current and need not be considered.

Rectifier Selection

The ICL7644-7647 use one external rectifier. To achieve specified performance at low voltage, a Schottky type, such as the 1N5818, is recommended because it combines low forward voltage drop with fast switching speed. This maximizes power conversion efficiency and output current when the DC-DC converter is in high power mode. One drawback of Schottky rectifiers is relatively high reverse leakage current (at 5V reverse, 1N5818 leakage is typically 60μA at +25°C and 450μA at +75°C), which is quite large with respect to the circuit's quiescent current in standby mode (typical standby current ICL7644/7646/7647 and ICL7644/7646/7647: 80μA, ICL7645: 40μA). If standby mode is not used or used only for short periods, reverse leakage is not a significant additional loss compared to the normal load current, and need not be considered.

If quiescent operating current is a primary concern, or if the ICL7644-7647 spends most of its time in standby mode, a silicon rectifier such as the 1N4933 or Unitrode UES1001 may be preferred. Silicon rectifiers have less reverse leakage current than do Schottky rectifiers (1N4933 leakage current is typically 1μA at +25°C and 50μA at +100°C). In circuits where the standby mode is the predominant mode of operation, battery life may be extended by trading conversion efficiency for lower standby quiescent current.

Output Current vs. Input Voltage

Figures 4 through 7 show output current versus input voltage using typical inductor values for each part in the ICL7644-7647 series. Where curves end in the middle of the graphs, the peak current limit of the internal LX2 switch has been reached. A higher input voltage than indicated by that line (for the given inductor) may damage the device. Figure 6 assumes that an IRF541 MOSFET is used (0.085V maximum on resistance).

Dashed lines indicate regions where the LX2 current limit hasn't been exceeded, but the current rating of the selected coil has. The actual voltages where lines end or become dashed are indicated by arrows on the graphs. The output currents indicated by dashed lines can be achieved only with inductors of higher current rating than the indicated coil. The coils used in Figures 4, 5 and 7 are as follows:

INDUCTOR	TOKO PART NUMBER
33 μ H	-0086K
47 μ H	-0088K
100 μ H	-0092K
150 μ H	-0094K
220 μ H	-0096K

The coils used in Figure 6 are the Toko series inductors.

The graphs in Figures 4-7 were calculated using worst case data, so individual circuits may supply more current than indicated. If the coils' current ratings are not exceeded, smaller, lower-cost coils than those indicated may be used in low-current applications. Use the equations in the text to calculate worst case peak coil/switch current to be sure that a particular coil's current rating is sufficient.

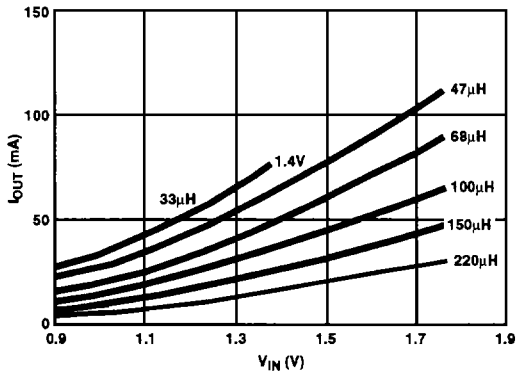

FIGURE 4. ICL7644, I_{OUT} vs. V_{IN} ($V_{OUT} = 5V$)

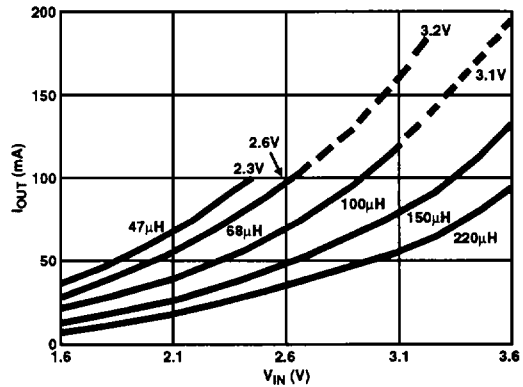

FIGURE 5. ICL7645, I_{OUT} vs. V_{IN} ($V_{OUT} = 5V$)

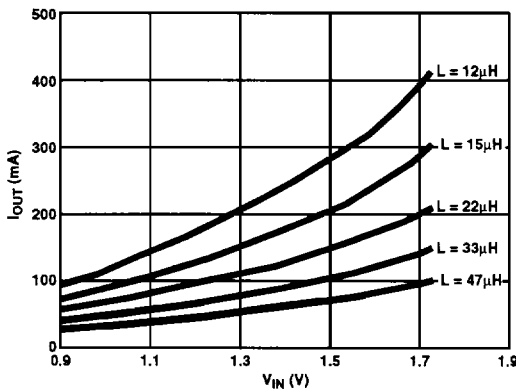

FIGURE 6. ICL7646, I_{OUT} vs. V_{IN} ($V_{OUT} = 5V$)

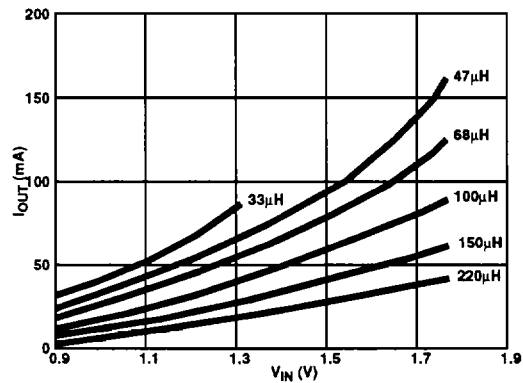

FIGURE 7. ICL7647, I_{OUT} vs. V_{IN} ($V_{OUT} = 3V$)