

THIS DOCUMENT IS THE PROPERTY OF KEYSTONE ELECTRONICS CORP. AND SHALL NOT BE REPRODUCED, DISTRIBUTED OR USED AS A BASIS FOR MANUFACTURE WITHOUT PRIOR WRITTEN PERMISSION FROM KEYSTONE ELECTRONICS CORP.

ACTUAL SIZE

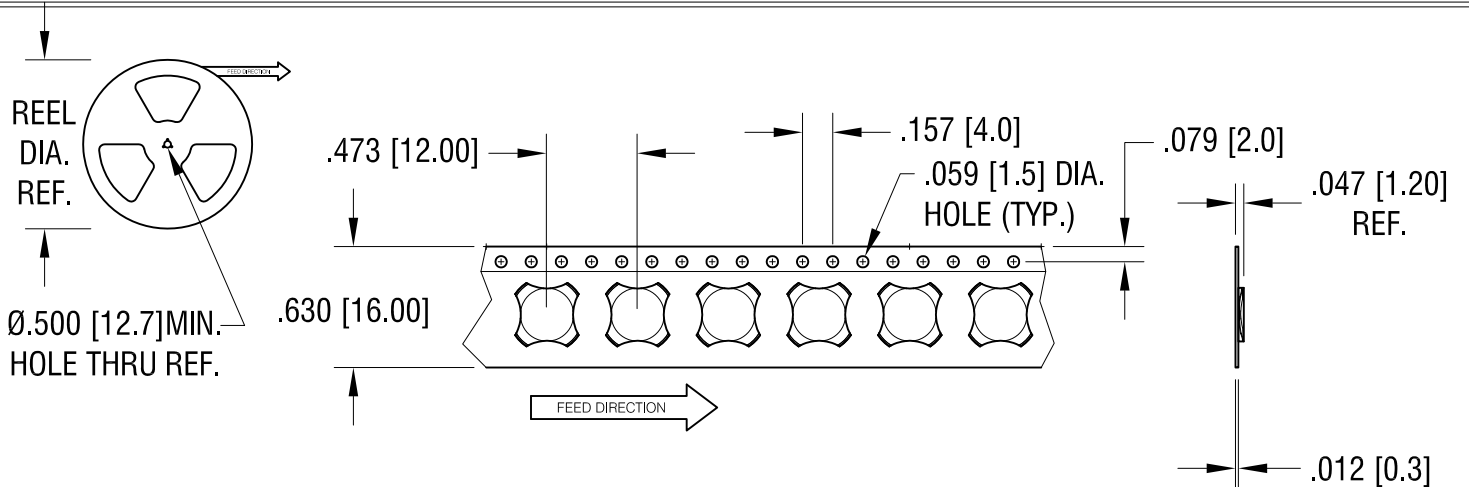
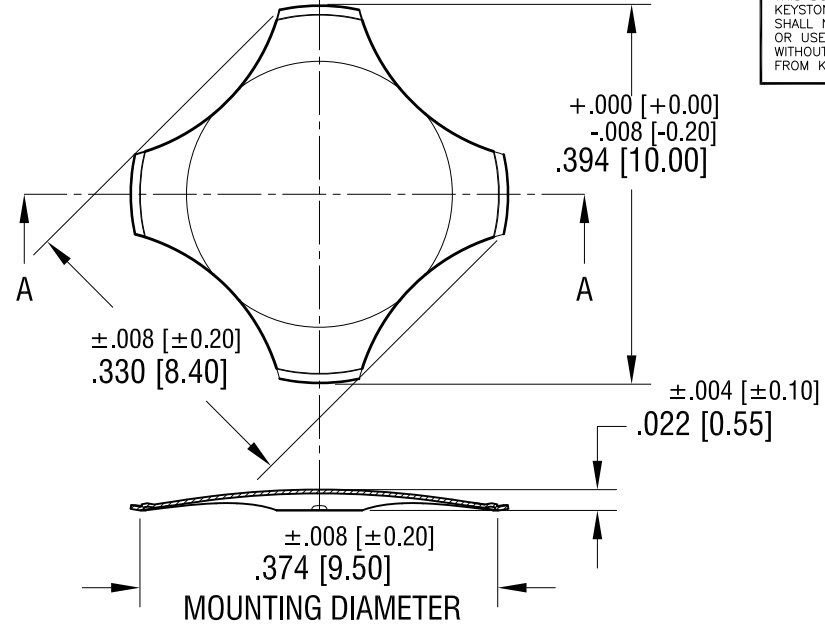
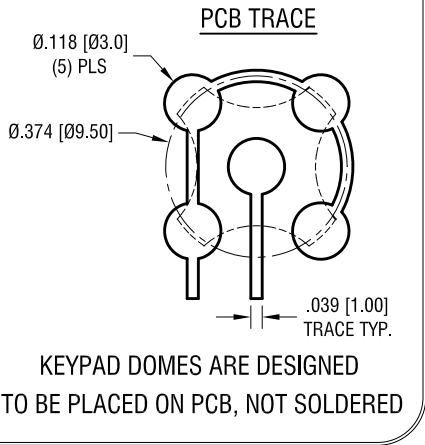

DOMES SPECIFICATIONS:

1. VOLTAGE/CURRENT MAXIMUM: 12mA@ 24 Volts DC
2. OPERATING TEMPERATURE: -40°C TO 105°C
3. STORAGE TEMPERATURE: -55°C TO 125°C
4. MAT'L: .004 [0.10] STAINLESS STEEL
5. FINISH: NICKEL PLATE
6. TRIP FORCE: 280g

NOTES: SUPPLIED ON TAPE AND REEL ONLY REF.

TAPE AND REEL SPECIFICATIONS:

1. TAPE:
MAT'L - ALL CONDUCTIVE POLYSTYRENE CARRIER
ANSI/EIA-481 STANDARD
2. REEL:
13.0 [330.2] DIA. 4000 PIECES PER REEL

9.03.21	DIMPLES REMOVED CARRIER TAPE WAS 24mm WIDE CHANGE AS PER ECN 21-102	A
DATE	DESCRIPTION	REV.

KEYSTONE ELECTRONICS CORP.			
www.keyelco.com • NEW HYDE PARK, NY 11040 • Tel (516) 328-7500			
PART NAME		COMPACT 4 LEGS DOME	
MATERIAL		AS NOTED	
FINISH	AS NOTED	DRN BY	NT
		DATE	2.15.17
		APP'D	RH
		SCALE	5X, 1X
TOLERANCES	INCH [MM]	CODE	DWG NO.
DECIMAL	± .005 [± 0.13]	C	
ANGULAR	± 1°		
UNLESS OTHERWISE SPECIFIED			
			5154TR