

Aavid Confidential

THE INFORMATION CONTAINED IN THIS DRAWING IS THE SOLE PROPERTY OF AAVID THERMALLOY. ANY REPRODUCTION IN PART OR AS A WHOLE WITHOUT THE WRITTEN PERMISSION OF AAVID THERMALLOY IS PROHIBITED.

THIS DRAWING IS CONTROLLED BY A CAD MODEL. IF IN DOUBT, PLEASE ASK.

REVISION HISTORY

REV	ZONE	REASON FOR CHANGE	REVISED BY	REV DATE	APPROVED BY	DATE APPROVED
C	-	BOM CHANGE PER ECN 1931	-	-	GL	4/13/04
D	-	RELEASE PER ECN 2634	-	-	WJB	12/1/06
E	-	UPDATED PER ECO #35207F4	-	11/18/2015	TNT	1/29/16

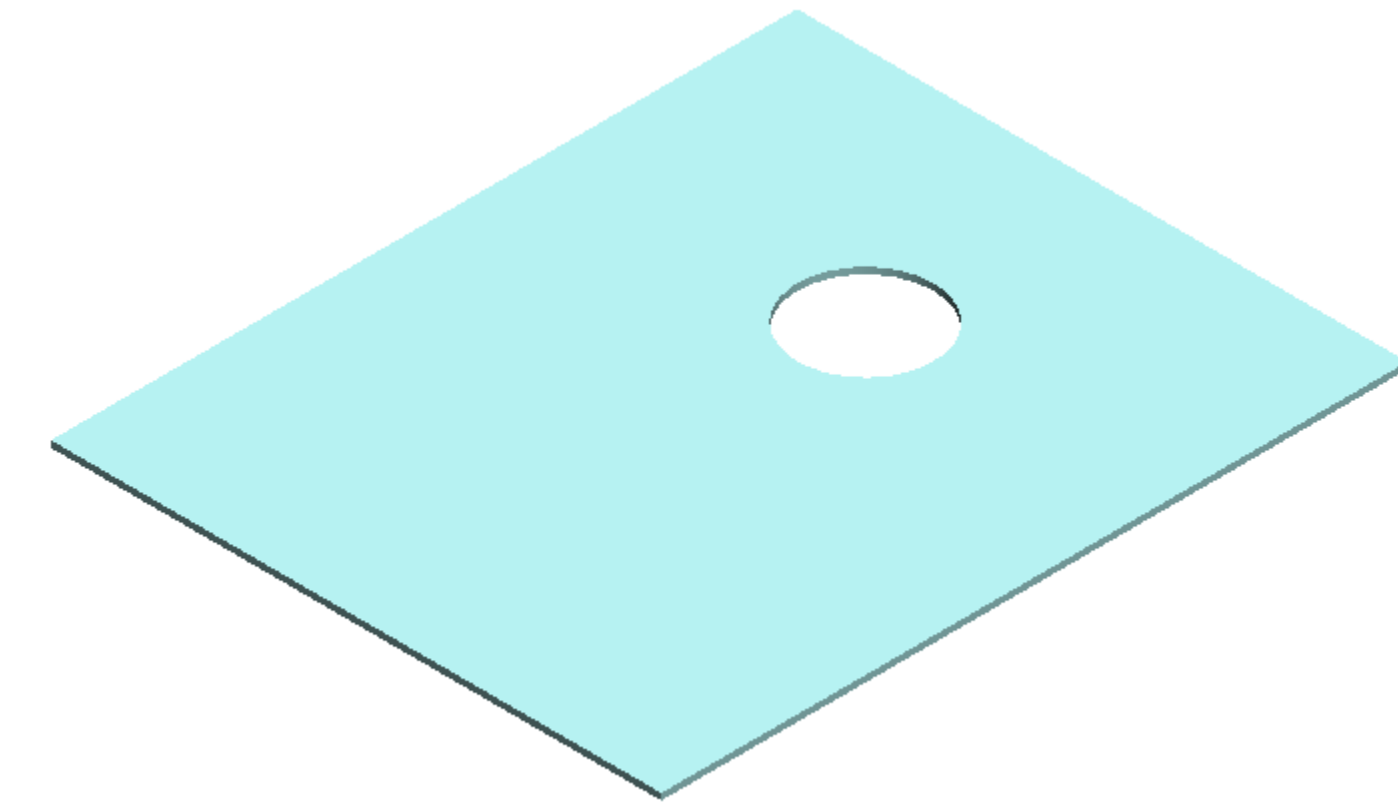
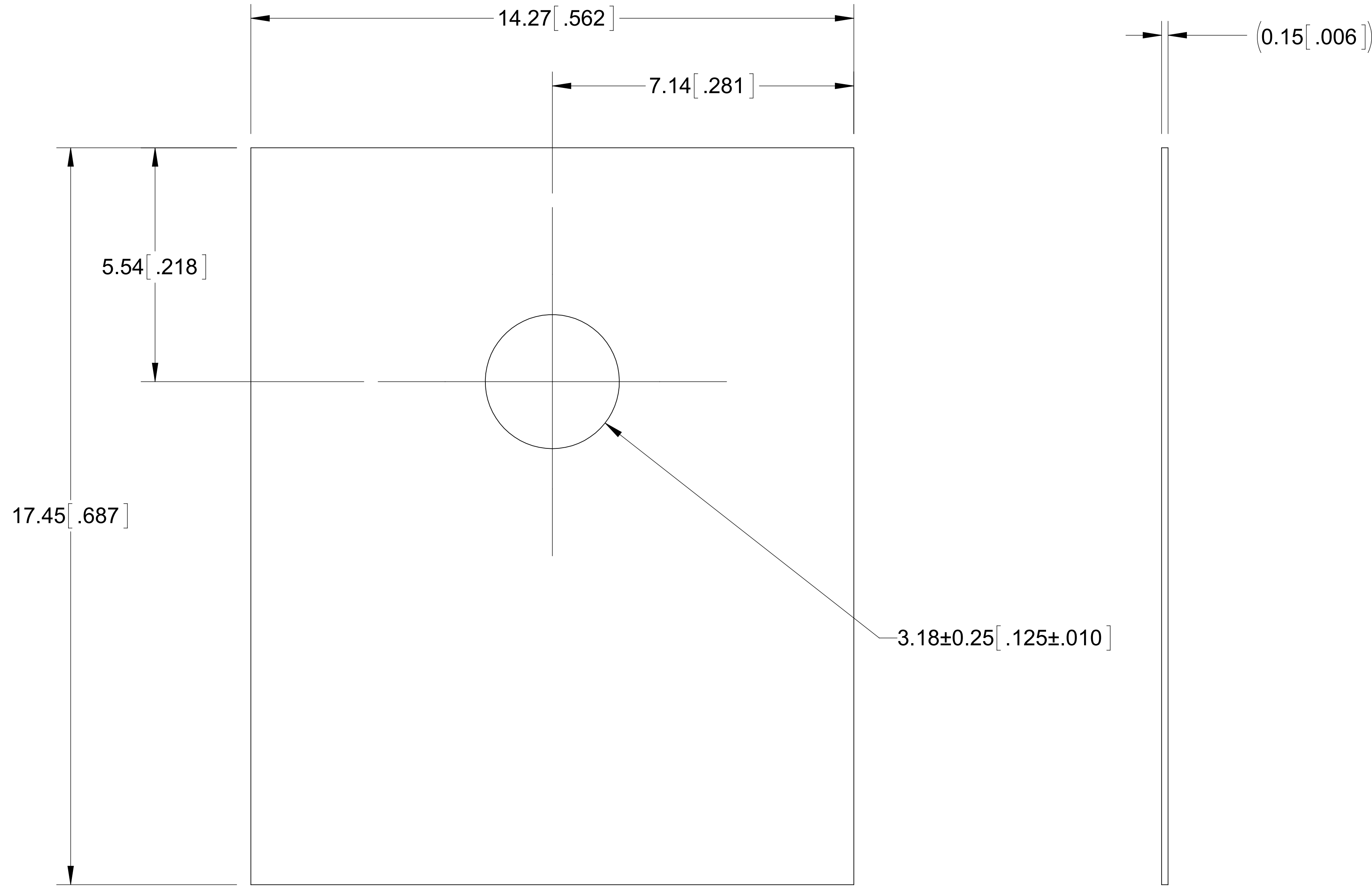

NOTES:

1. MAKE FROM 035444
2. REF P/N: THM,53-77-2G

<p>THIRD ANGLE PROJECTION</p>		<p>Aavid Thermalloy, LLC 67 Primrose Drive, Laconia, NH 03246, USA www.aavidthermalloy.com</p>			<p>DIVISION MFG-LC</p>	
<p>PART TYPE IS STAMPING DIMENSIONS ARE IN mm [INCH] TOLERANCES UNLESS OTHERWISE SPECIFIED X± 1.520 [X± 0.06] .X± 0.760 [.XX± 0.03] .XX± 0.125 [XXX 0.015] Angle 1° REMOVE ALL BURRS BREAK SHARP EDGES .13 - .38 [.005 - .015] PART TO BE FREE OF DIRT, OIL, OR DEBRIS 0.8/MACHINED SURFACES</p>		<p>DESCRIPTION PAD, GTR, .006X.562X00.687MOD1G</p>				<p>SIZE D</p>
<p>DRAWN BY M.BAILEY</p>		<p>DATE 11/18/2015</p>	<p>MATERIAL SEE NOTES</p>			
<p>CHECKED BY</p>		<p>DATE</p>	<p>FINISH</p>			
<p>APPROVED BY T. TONDREAU</p>		<p>DATE 1/29/2016</p>	<p>SHEET 1 of 1</p>	<p>SCALE NONE</p>	<p>PART NUMBER 034744</p>	<p>REV --E</p>

RoHS COMPLIANT
PER AAVID SPEC ROHS - 9000