

DRAWING FOR REFERENCE: This is subject to change without notice

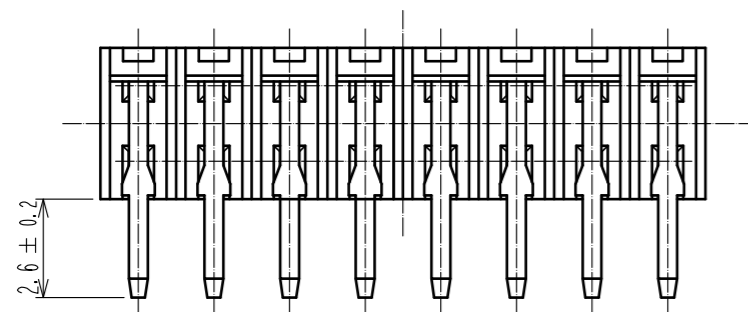
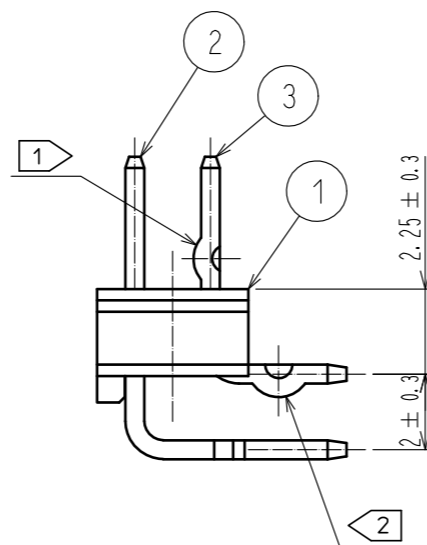
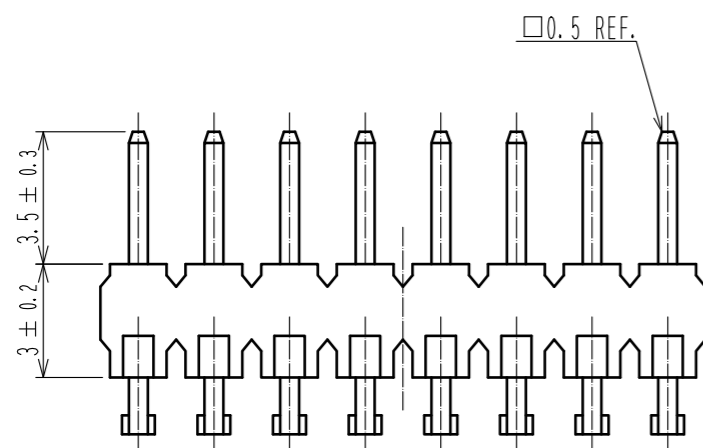
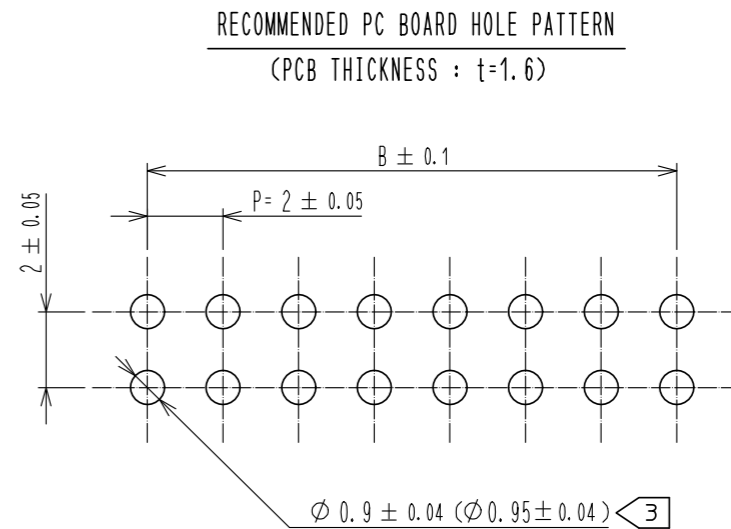
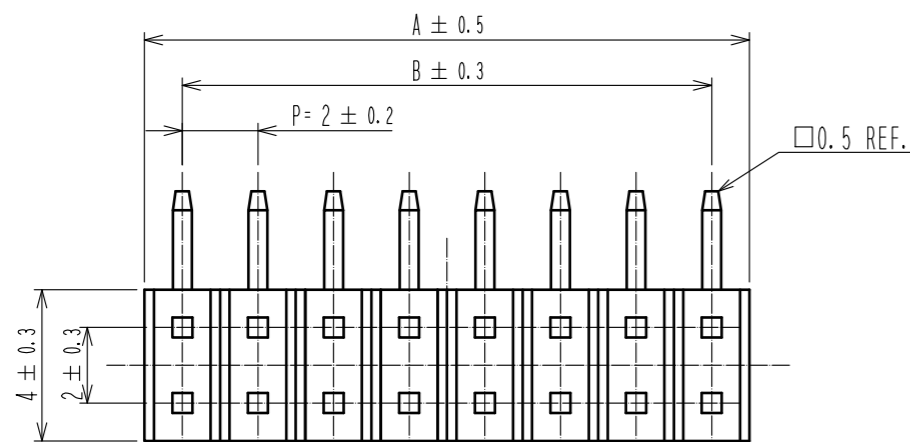

PART NO.	CODE NO.	PIN	A	B	KINKED POSITION 1 ◁ 1	KINKED POSITION 2 ◁ 2
MA35- 6P-2DS(51)	CL588-0299-7-51	6	6	4	1 OR 2 PINS ON EVERY OTHER PINS	1 OR 2 PINS ON EVERY OTHER PINS
MA35- 8P-2DS(51)	CL588-0331-8-51	8	8	6	2 PINS ON EVERY OTHER PINS	2 PINS ON EVERY OTHER PINS
MA35-10P-2DS(51)	CL588-0321-4-51	10	10	8	2 OR 3 PINS ON EVERY OTHER PINS	2 OR 3 PINS ON EVERY OTHER PINS
MA35-12P-2DS(51)	CL588-0363-4-51	12	12	10	3 PINS ON EVERY OTHER PINS	3 PINS ON EVERY OTHER PINS
MA35-14P-2DS(51)	CL588-0318-0-51	14	14	12	3 OR 4 PINS ON EVERY OTHER PINS	3 OR 4 PINS ON EVERY OTHER PINS
MA35-16P-2DS(51)	CL588-0359-7-51	16	16	14	4 PINS ON EVERY OTHER PINS	4 PINS ON EVERY OTHER PINS
MA35-18P-2DS(51)	CL588-0317-7-51	18	18	16	4 OR 5 PINS ON EVERY OTHER PINS	4 OR 5 PINS ON EVERY OTHER PINS
MA35-20P-2DS(51)	CL588-0312-3-51	20	20	18	5 PINS ON EVERY OTHER PINS	5 PINS ON EVERY OTHER PINS
MA35-22P-2DS(51)	CL588-0360-6-51	22	22	20	5 OR 6 PINS ON EVERY OTHER PINS	5 OR 6 PINS ON EVERY OTHER PINS
MA35-24P-2DS(51)	CL588-0369-0-51	24	24	22	6 PINS ON EVERY OTHER PINS	6 PINS ON EVERY OTHER PINS
MA35-26P-2DS(51)	CL588-0379-4-51	26	26	24	6 OR 7 PINS ON EVERY OTHER PINS	6 OR 7 PINS ON EVERY OTHER PINS
MA35-28P-2DS(51)	CL588-0366-2-51	28	28	26	7 PINS ON EVERY OTHER PINS	7 PINS ON EVERY OTHER PINS
MA35-30P-2DS(51)	CL588-0364-7-51	30	30	28	7 OR 8 PINS ON EVERY OTHER PINS	7 OR 8 PINS ON EVERY OTHER PINS
MA35-32P-2DS(51)	CL588-0319-2-51	32	32	30	8 PINS ON EVERY OTHER PINS	8 PINS ON EVERY OTHER PINS
MA35-40P-2DS(51)	CL588-0365-0-51	40	40	38	10 PINS ON EVERY OTHER PINS	10 PINS ON EVERY OTHER PINS
MA35-44P-2DS(51)	CL588-0371-2-51	44	44	42	11 PINS ON EVERY OTHER PINS	11 PINS ON EVERY OTHER PINS
MA35-50P-2DS(51)	CL588-0320-1-51	50	50	48	12 OR 13 PINS ON EVERY OTHER PINS	12 OR 13 PINS ON EVERY OTHER PINS
MA35-52P-2DS(51)	CL588-0368-8-51	52	52	50	13 PINS ON EVERY OTHER PINS	13 PINS ON EVERY OTHER PINS
MA35-62P-2DS(51)	CL588-0403-7-51	62	62	60	15 OR 16 PINS ON EVERY OTHER PINS	15 OR 16 PINS ON EVERY OTHER PINS

NOTE
 1 KINKED POSITION 1 IS SHOWN IN THE TABLE.
 2 KINKED POSITION 2 IS SHOWN IN THE TABLE.
 3 THROUGH HOLE DIMENSION SHALL BE 0.95 ± 0.04 WHEN NUMBER OF POSITIONS IS MORE THAN 26.

1	POLYAMIDE	BLACK	UL94V-0	2, 3	BRASS	SURFACE : TIN-PLATING 3μm
NO.	MATERIAL	FINISH	REMARKS	NO.	MATERIAL	UNDER PLATING : NICKEL 1μm
UNITS mm	⊙	SCALE 5 : 1	COUNT	DESCRIPTION OF REVISIONS		DESIGNED
APPROVED : NH. NAKATA		17. 04. 10		DRAWING NO.		EDC-375933-00-00
CHECKED : HT. YAMAGUCHI		17. 04. 10		PART NO.		MA35- * P-2DS(51)
DESIGNED : HR. NAGAYASU		17. 04. 10		CODE NO.		CL588
DRAWN : HR. NAGAYASU		17. 04. 10				1/1