

# PRODUCT SPECIFICATION

<b>Part Number</b>	FFC3XXX	<b>Rev</b>	B	<b>Date</b>	16/06/10		
<b>Product Description</b>	1.0mm Pitch ZIF FPC				<b>Page</b>	1	
<b>Doc Number</b>	1.0mm FFC Spec	<b>Prepared</b>	<b>PN</b>	<b>Checked</b>	<b>SA</b>	<b>Approved</b>	<b>LH</b>

Top Entry

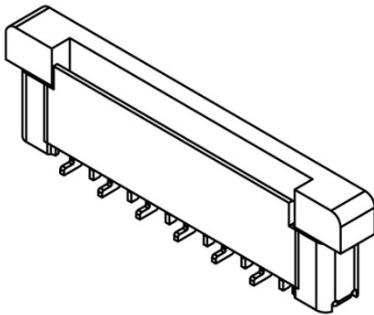

Side Entry

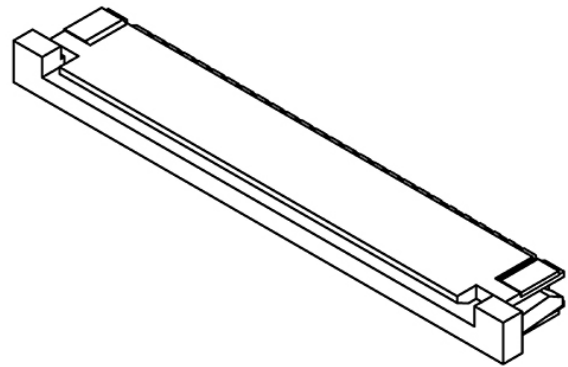

# PRODUCT SPECIFICATION

<b>Part Number</b>	FFC3XXX	<b>Rev</b>	B	<b>Date</b>	16/06/10		
<b>Product Description</b>	1.0mm Pitch ZIF FPC			<b>Page</b>	2		
<b>Doc Number</b>	1.0mm FFC Spec	<b>Prepared</b>	<b>PN</b>	<b>Checked</b>	<b>SA</b>	<b>Approved</b>	<b>LH</b>

## 1.0 SCOPE.

This specification covers performance, tests and quality requirements for 1.0mm Pitch ZIF FPC Connector

## 2.0 APPLICABLE DOCUMENTS.

EIA-364 Electronics Industries Association

## 3.0 REQUIREMENTS.

### 3.1 Design and Construction

Product shall be of design, construction and physical dimensions specified on applicable product drawing.

### 3.2 Materials and Finish

- 3.2.1 Housing: High-Temp Plastic LCP (UL94V-0), White
- 3.2.2 Actuator: LCP (UL94V-0), Black
- 3.2.3 Contact: High performance copper alloy (phosphor bronze)
  - Finish: (a) Finish: see ordering information
  - (b) Under-plate: Nickel-plated all over
- 3.2.4 Fitting Nail: Brass, Tin-plated overall

### 3.3 Ratings

- 3.3.1 Voltage rating: 50V AC
- 3.3.2 Current rating: 0.4A
- 3.3.3 Operating Temperature Range: -25°C to +85°C

# PRODUCT SPECIFICATION

<b>Part Number</b>	FFC3XXX	<b>Rev</b>	B	<b>Date</b>	16/06/10
<b>Product Description</b>	1.0mm Pitch ZIF FPC			<b>Page</b>	3
<b>Doc Number</b>	1.0mm FFC Spec	<b>Prepared</b>	<b>PN</b>	<b>Checked</b>	<b>SA</b>
				<b>Approved</b>	<b>LH</b>

## 4.0 PERFORMANCE.

Item	Test Condition	Requirement
Examination of Product	Visual, dimensional and functional per applicable quality inspection plan.	Product shall meet requirements of applicable product drawing and specification.

## 4.1 Electrical Performance.

Item	Test Condition	Requirement
Low-signal Level Contact Resistance	Mate connectors, measure by dry circuit, 20mV Max., 100mA Max., in accordance with EIA-364-23.	20 m $\Omega$ Max.(initial)per contact 40 m $\Omega$ Max. Change allowed
Insulation Resistance	Unmated connectors, apply 250 V DC between adjacent terminals, in accordance with EIA-364-21.	100 M $\Omega$ Min.
Dielectric Withstanding Voltage	Test between adjacent contacts of unmated connectors, in accordance with EIA-364-20.	250 VAC Min. at sea level for 1 minute. No discharge, flashover or breakdown. Current leakage: 0.5 mA max.
Temperature Rise	Mate connector: measure the temperature rise at rated current after: 0.5 A/Power contact. The temperature rise above ambient shall not exceed 30°C The ambient condition is still air at 25°C, in accordance with EIA-364-70, METHOD 2.	30°C Max. Change allowed

## 4.2 Mechanical Performance.

Item	Test Condition	Requirement
Durability	The sample should be mounted in the tester and fully mated and unmated the number of cycles specified at the rate of 10 $\pm$ 3mm/min, in accordance with EIA-364-09.	20 cycles
FPC Retention Force	Insert the actuator, pull the FPC at the speed rate of 10 $\pm$ 3 mm/min.	Refer to FPC withdrawal force Refer to GROUP 8.

# PRODUCT SPECIFICATION

<b>Part Number</b>	FFC3XXX	<b>Rev</b>	B	<b>Date</b>	16/06/10
<b>Product Description</b>	1.0mm Pitch ZIF FPC			<b>Page</b>	4
<b>Doc Number</b>	1.0mm FFC Spec	<b>Prepared</b>	<b>PN</b>	<b>Checked</b>	<b>SA</b>
				<b>Approved</b>	<b>LH</b>

Item	Test Condition	Requirement
Repeated Actuator Insertion/Withdrawal	Insert and withdraw actuator up to 20 cycles at the speed rate of less than 10 cycles/minute.	60 mΩ Max.
Terminal/Housing Retention Force	Apply axial pull out force at the speed rate of 10 ±3 mm/minute. On the terminal assembled in the housing.	0.15kgf MIN.
Fitting Nail/Housing Retention Force	Apply axial pull out force at the speed rate of 10 ±3 mm/minute. On the fitting nail assembled in the housing.	0.01kgf MIN.
Vibration	The electrical load condition shall be 100 mA maximum for all contacts. Subject to a simple harmonic motion having amplitude of 0.76mm (1.52mm maximum total excursion) in frequency between the limits of 10 and 55 Hz. The entire frequency range, from 10 to 55 Hz and return to 10 Hz, shall be traversed in approximately 1 minute. This motion shall be applied for 2 hours in each of three mutually perpendicular directions. In accordance with EIA-364-28, Condition I	No Damage 60mΩ MAX 1 u sec Max.
Shock (Mechanical)	Subject mated connectors to 50 G's (peak value) half-sine shock pulses of 11 milliseconds duration. Three shocks in each direction shall be applied along the three mutually perpendicular axes of the test specimen (18 shocks). The electrical load condition shall be 100mA maximum for all contacts. In accordance with EIA-364-27, test condition A	No Damage 60mΩ MAX 1 u sec Max.

# PRODUCT SPECIFICATION

<b>Part Number</b>	FFC3XXX	<b>Rev</b>	B	<b>Date</b>	16/06/10
<b>Product Description</b>	1.0mm Pitch ZIF FPC			<b>Page</b>	5
<b>Doc Number</b>	1.0mm FFC Spec	<b>Prepared</b>	<b>PN</b>	<b>Checked</b>	<b>SA</b>
				<b>Approved</b>	<b>LH</b>

## 4.3 Environmental Performance.

Item	Test Condition	Requirement
Resistance to Reflow Soldering Heat	Pre Heat: 150°C~180°C, 60~90sec. Heat: 230°C Min., 40sec Min. Peak Temp.: 260°C Max, 10sec Max.	See Product Qualification and Test Sequence Group 9
Resistance to Hand Soldering Heat	Soldering iron: 350±10°C Duration: 3~4 sec.	Excessive pressure shall not be applied to the terminals. See Product Qualification and Test Sequence Group 10
Thermal Shock	Mate module and subject to follow condition for 5 cycles. 1 cycles: -40 +0/-3°C, 30 minutes +85 +3/-0°C, 30 minutes In accordance with EIA-364-32, test condition A	No Damage 60mΩ MAX 1 u sec Max
Humidity	Mated Connector 40°C, 90~95% RH, Refer to Method II. In accordance with EIA-364-31, test condition A	No Damage 60mΩ MAX 20MΩ Min.
Temperature Life	Subject mated connectors to temperature life at 85°C for 96 hours. Measure Signal. In accordance with EIA-364-17, test condition A	No Damage 60mΩ MAX
SO2 Gas	Mate applicable FPC and expose them to the following SO2 gas atmosphere. Temperature: 40±2°C Gas Density: 50±5 ppm Duration: 24 hours	No Damage 60mΩ MAX
Salt Spray	Subject mated/unmated connectors to 5% salt-solution concentration, 35°C for 48 hours. In accordance with EIA-364-26, test condition B	No Damage 60mΩ MAX
Solderability	Subject the test area of contacts into the flux for 5-10 sec. And then into solder bath, Temperature at 245 ±5°C, for 4-5 sec. In accordance with EIA-364-52	Solderable area shall have minimum of 95% solder coverage.
<div style="display: inline-block; border: 1px solid black; padding: 2px;">Halogen Free</div> 	Test report available on request	-

Note. Flowing Mixed Gas shall be conducted by customer request.

# PRODUCT SPECIFICATION

<b>Part Number</b>	FFC3XXX	<b>Rev</b>	B	<b>Date</b>	16/06/10		
<b>Product Description</b>	1.0mm Pitch ZIF FPC				<b>Page</b>	6	
<b>Doc Number</b>	1.0mm FFC Spec	<b>Prepared</b>	<b>PN</b>	<b>Checked</b>	<b>SA</b>	<b>Approved</b>	<b>LH</b>

## 5.0 INFRA RED REFLOW CONDITION.

### 5.1 Lead-Free Process: Duration = 2 times

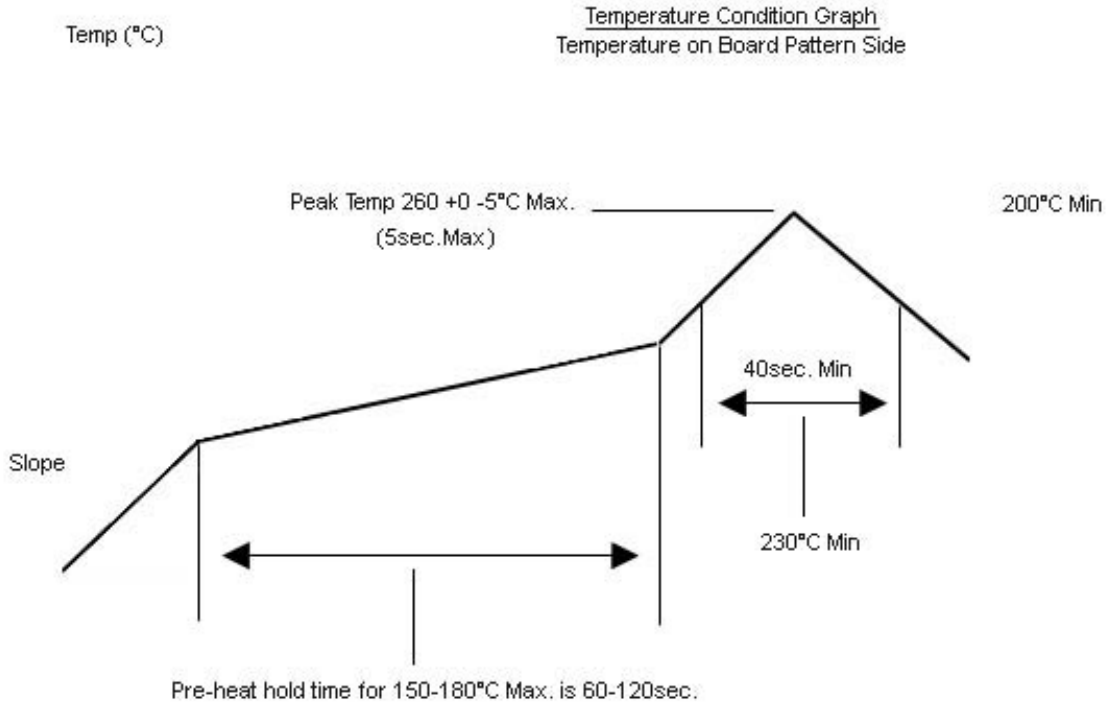

# PRODUCT SPECIFICATION

<b>Part Number</b>	FFC3XXX	<b>Rev</b>	B	<b>Date</b>	16/06/10		
<b>Product Description</b>	1.0mm Pitch ZIF FPC			<b>Page</b>	7		
<b>Doc Number</b>	1.0mm FFC Spec	<b>Prepared</b>	<b>PN</b>	<b>Checked</b>	<b>SA</b>	<b>Approved</b>	<b>LH</b>

## 6.0 PRODUCT QUALIFICATION AND TEST SEQUENCE.

Test or Examination	Test Group									
	1	2	3	4	5	6	7	8	9	10
	Test Sequence									
Examination of Product				1,7	1,6	1,4			1	
Low-signal Level Contact Resistance		1,5	1,4	2,10	2,9	2,5			3	
Insulation Resistance				3,9	3,8					
Dielectric Withstanding Voltage				4,8	4,7					
Temperature Rise	1									
Mating / Unmating Forces		2,4								
Durability		3								
Vibration			2							
Shock (Mechanical)			3							
Thermal Shock				5						
Humidity				6						
Temperature Life					5					
Salt Spray						3				
Solderability							1			
Repeated Actuator Insertion/Withdrawal								1		
FPC Retention Force								2		
Terminal / Housing Retention Force								3		
Fitting Nail / Housing Retention Force								4		
Resistance to Soldering Heat									2	
Resistance to Hand Soldering Heat										1
Sample Size	2	4	4	4	4	4	2	4	4	4

# PRODUCT SPECIFICATION

<b>Part Number</b>	FFC3XXX	<b>Rev</b>	B	<b>Date</b>	16/06/10
<b>Product Description</b>	1.0mm Pitch ZIF FPC			<b>Page</b>	8
<b>Doc Number</b>	1.0mm FFC Spec	<b>Prepared</b>	<b>PN</b>	<b>Checked</b>	<b>SA</b>
				<b>Approved</b>	<b>LH</b>

## 7.0 FPC WITHDRAWAL FORCE.

No. Of Ckt.	Withdrawal Force (Min)	No. Of Ckt.	Withdrawal Force (Min)
4	0.3Kgf	29	1.0Kgf
5			
6			
7			
8			
9			
10			
11	0.5Kgf	30	1.5Kgf
12			
13			
14			
15			
16			
17			
18			
19			
20			
21	1.0Kgf	31	1.5Kgf
22			
23			
24			
25			
26			
27			
28			
		32	
		33	
		34	
		35	
		36	
		37	
		38	
		39	
		40	
		41	
		42	
		43	
		44	
		45	
		46	
		47	
		48	
		49	
		50	
		51	
		52	
		53	

Revision Details:



# PRODUCT SPECIFICATION

<b>Part Number</b>	FFC3XXX	<b>Rev</b>	B	<b>Date</b>	16/06/10		
<b>Product Description</b>	1.0mm Pitch ZIF FPC				<b>Page</b>	9	
<b>Doc Number</b>	1.0mm FFC Spec	<b>Prepared</b>	<b>PN</b>	<b>Checked</b>	<b>SA</b>	<b>Approved</b>	<b>LH</b>

Revision	Information	Page	Release Date
A	Specification Released	-	16/06/2010
B	Leaded temperature profile removed	5 & 6	26/11/2015