

REVISIONS				
P	LTR	DESCRIPTION	DATE	APVD
N3		REVISED PER ECN-22-150900	28APR2022	RK CSD

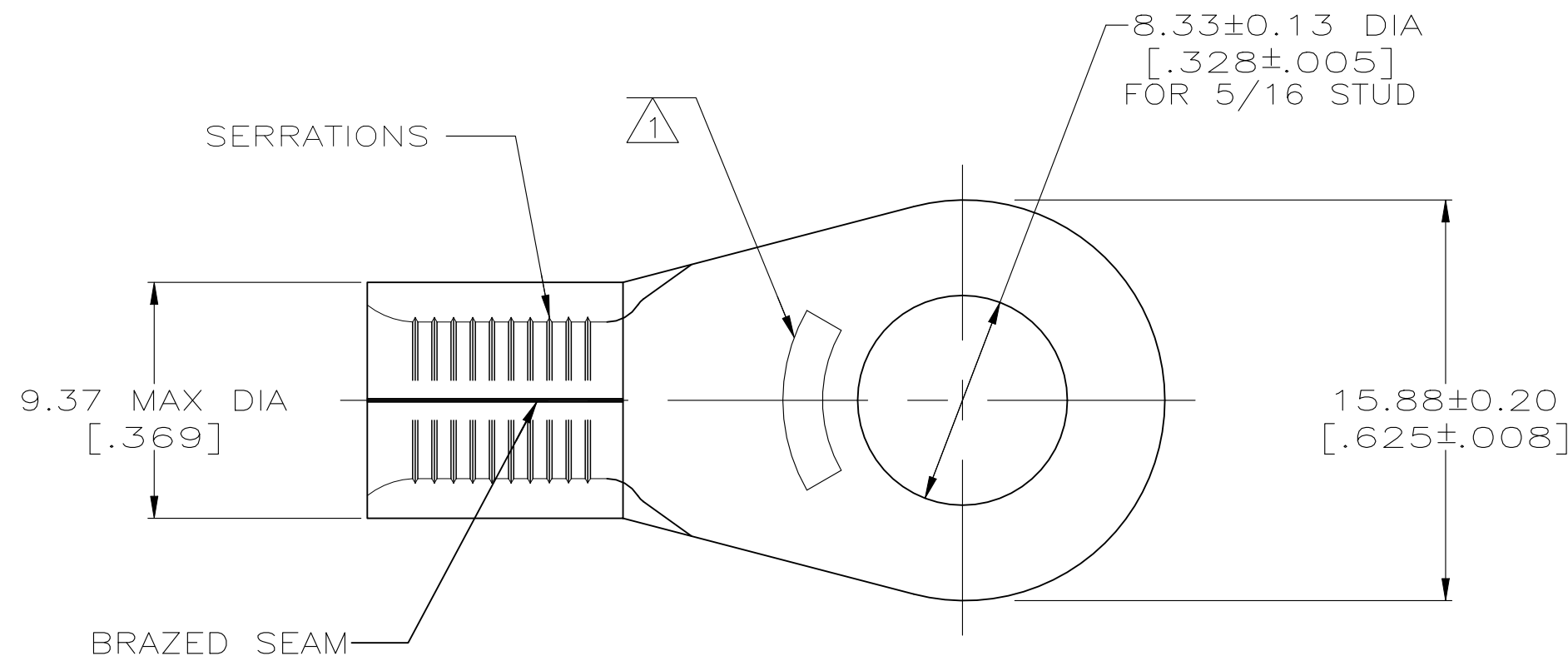

<b>AMP</b> WIRE RANGE	Listed FILE E13288
6 AWG SOLID OR STRANDED	6 AWG STRANDED
LR7189 Certified	
6 AWG SOLID OR STRANDED	

- ① STAMP AMP 6\* APPROX AS SHOWN
- ② 0.00254 [.000100] MIN TIN PLATE PER ASTM B-545.
- ③ GOLD PLATE 0.00127 [.000050] MIN THK PER ASTM B-488, TYPE 2, GRADE C OVER NICKEL PLATE 0.00076 [.000030] MIN THK PER QQ-N-290.
- ④ SUPERSEDED BY 8-33466-3
- ⑤ COPPER PER ASTM B-152, ANNEALED

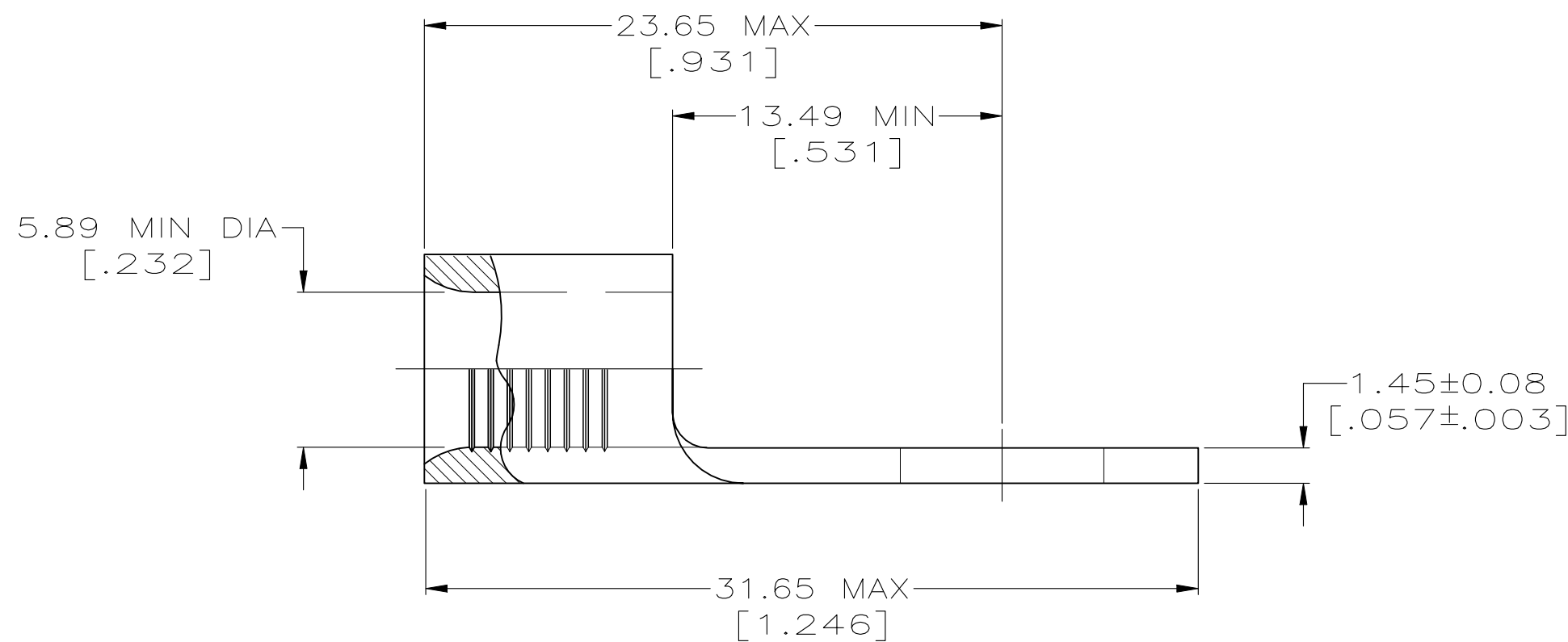

FINISH	QTY	PACKAGE TYPE	PART NO
②	25	LOOSE PIECE, BAG	8-33466-5 ④
②	25	LOOSE PIECE, BOX	8-33466-3
②	500	LOOSE PIECE, BOX	<del>2-33466-4</del>
②	750	33466 ON TAPE	2-33466-3
③	----	LOOSE PIECE	2-33466-1
②	----	LOOSE PIECE	33466

<b>AMP INCORPORATED CUSTOMER SERVICE SYSTEMS</b>		MAX RECOMMENDED OPERATING TEMPERATURE: 170°C
FOR ADDITIONAL PRODUCT INFORMATION OR COPIES OF DRAWINGS AND TECHNICAL DOCUMENTS	PRODUCT INFORMATION CENTER 1-800-522-6752	VOLTAGE RATING: N/A
FOR APPLICATION TOOLING INFORMATION	TOOLING ASSISTANCE CENTER 1-800-722-1111	CIRCULAR MIL AREA: 10.5-16.8mm <sup>2</sup> [20,800-33,100] SOLID OR STRANDED
FOR ORDER ENTRY	1-800-526-5142	THIS DRAWING IS A CONTROLLED DOCUMENT FOR AMP INCORPORATED. IT IS SUBJECT TO CHANGE AND THE CONTROLLING ENGINEERING ORGANIZATION SHOULD BE CONTACTED FOR THE LATEST REVISION.

THIS DRAWING IS A CONTROLLED DOCUMENT.		DWN TA BRINKMAN 3-24-93	TE Connectivity	
DIMENSIONS: mm[INCHES]		CHK DA PATTERSON 3-24-93	NAME JL MECKLEY 3-24-93	
TOLERANCES UNLESS OTHERWISE SPECIFIED: 0 PLC ± - 1 PLC ± - 2 PLC ± - 3 PLC ± - 4 PLC ± - ANGLES ± -		APVD JL MECKLEY 3-24-93	PRODUCT SPEC APPLICATION SPEC	
MATERIAL - ⑤	FINISH SEE TABLE	WEIGHT -	SIZE A2	CAGE CODE 00779
CUSTOMER DRAWING		DRAWING NO C=33466	RESTRICTED TO -	SCALE 4:1
		SHEET 1 OF 1	REV N3	