

10 9 8 7 6 5 4 3 2 1

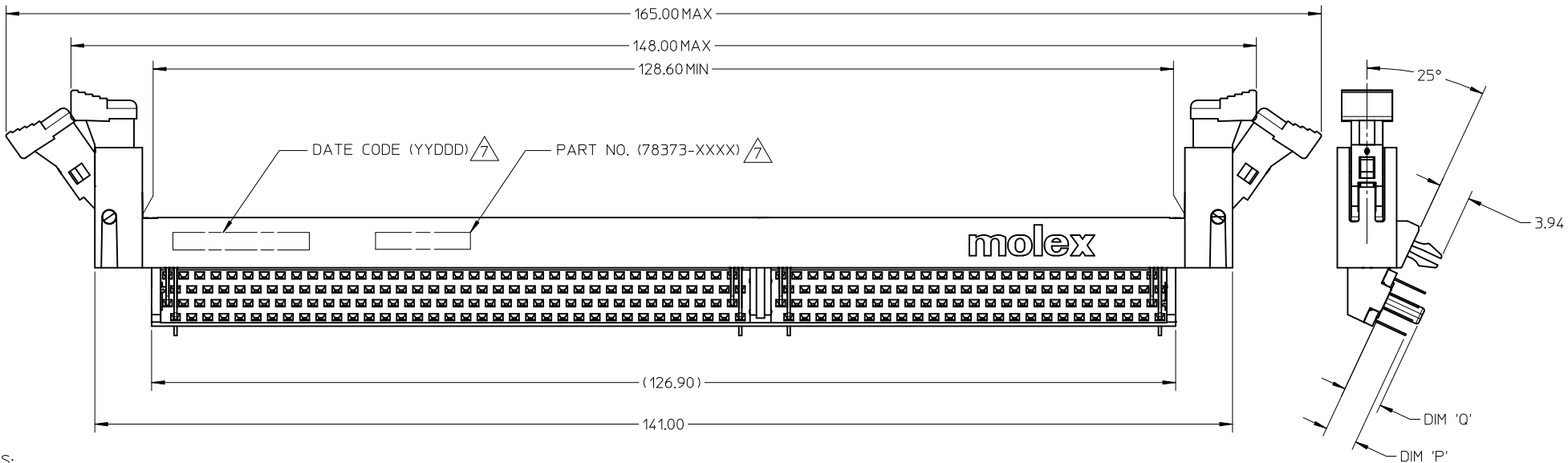
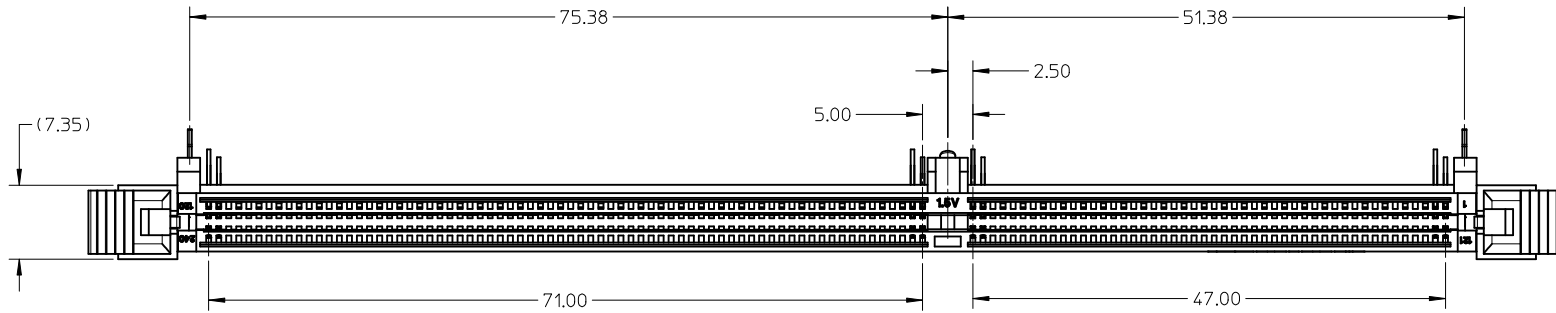

NOTES:

- MATERIALS:
HOUSING & BASEPLATE - LCP, GLASS-FILLED, UL94V-0, BLACK
LATCH - HIGH TEMPERATURE NYLON, GLASS-FILLED, UL94V-0, BLACK
TERMINALS & FORKLICK - COPPER ALLOY
 - PLATING : CONTACT AREA - SEE TABLE IN SHEET 5
SOLDERTAIL - SEE TABLE IN SHEET 5
 - CARD SLOT ACCEPTS 1.27±0.10MM MODULE THICKNESS (MEASURE OVER PC PAD)
 - REFER TO PRODUCT SPECIFICATION PS-78373-001 FOR PERFORMANCE SPECIFICATION
 - RECOMMENDED MODULE CARD LAYOUT SHELL BE AS PER JEDEC MO-269
 - PRODUCT SHALL BE PACKED IN TRAY
- MOLEX LOGO , DATE CODE PART NUMBER INDICATED ON HOUSING

ADDED CORING EC NO: S2010-0787 DRW:CCTEH 2010/03/22 CHKD:CGTAN 2011/01/24 APPR:SHLENI 2011/01/24	QUALITY SYMBOLS $F_A=0$ $F_B=0$ $F_P=0$	GENERAL TOLERANCES (UNLESS SPECIFIED)		DIMENSION STYLE MM ONLY		SCALE NTS	DESIGN UNITS METRIC	THIRD ANGLE PROJECTION	
			mm	INCH	DRAWN BY CCTEH	DATE 2008/01/30	TITLE DDR3 DIMM, 100MM PITCH 240 CKTS, 25 DEG, T/H		
		4 PLACES	± ---	± ---	CHECKED BY CGTAN	DATE 2008/04/07	MOLEX INCORPORATED DOCUMENT NO. SD-78373-001		
		3 PLACES	± ---	± ---	APPROVED BY SHLENI	DATE 2008/04/08			
	2 PLACES	± 0.25	± ---	MATERIAL NO.		SHEET NO.			
	1 PLACE	± ---	± ---	SEE TABLE		1 OF 5			
DRAFT WHERE APPLICABLE MUST REMAIN WITHIN DIMENSIONS		ANGULAR ± 3 °		THIS DRAWING CONTAINS INFORMATION THAT IS PROPRIETARY TO MOLEX INCORPORATED AND SHOULD NOT BE USED WITHOUT WRITTEN PERMISSION					

9 8 7 6 5 4 3 2 1

10 9 8 7 6 5 4 3 2 1

F

E

D

C

B

A

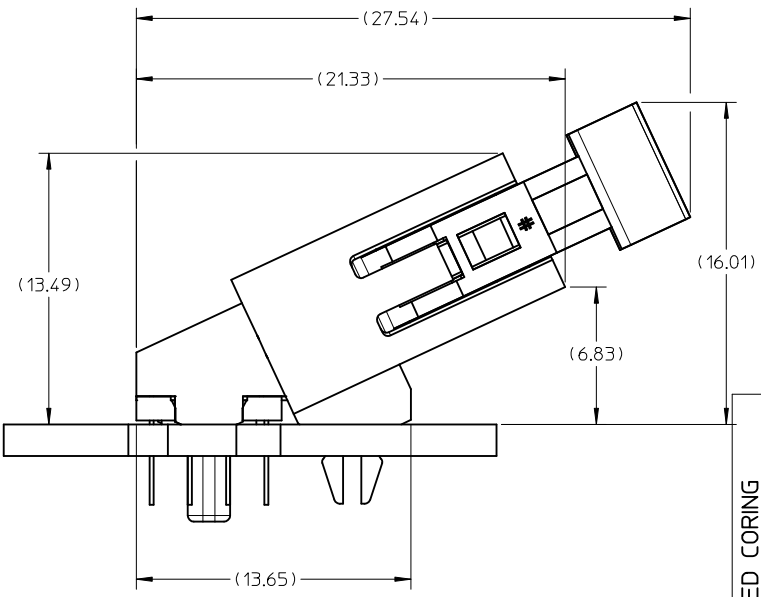
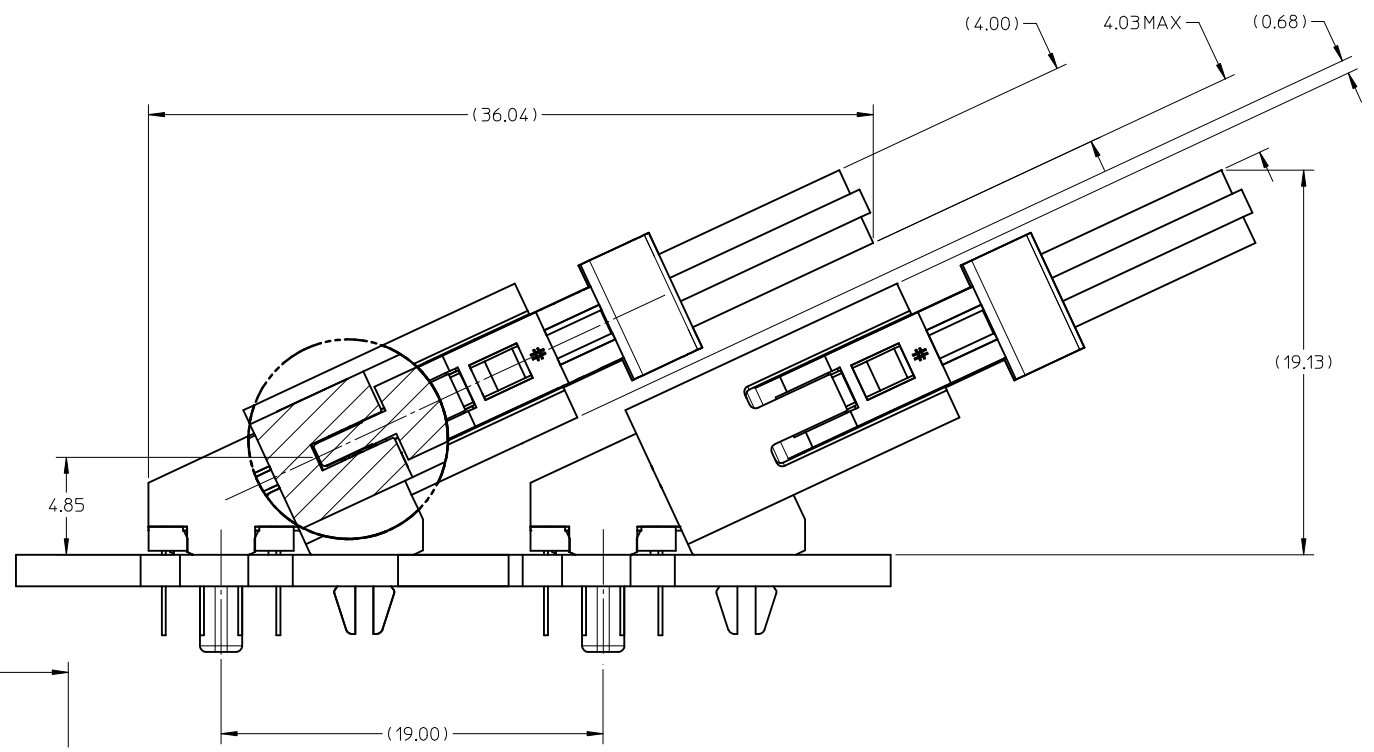

MINIMUM RECOMMENDED ROW TO ROW SPACING WHEN USING 4.00MM THICK MODULE (TYPICAL TSOP PACKAGING)

ADDED CORING	DESCRIPTION
EC NO: S2010-0787	2010/03/22
DRWN:CTEH	2011/01/24
CHKD:CGTAN	2011/01/24
APPR:SHLENI	2011/01/24
REV	
A	

QUALITY SYMBOLS
$\nabla_A = 0$
$\nabla_C = 0$
$\nabla_F = 0$

GENERAL TOLERANCES (UNLESS SPECIFIED)	
	mm INCH
4 PLACES	\pm --- \pm ---
3 PLACES	\pm --- \pm ---
2 PLACES	\pm 0.25 \pm ---
1 PLACE	\pm --- \pm ---
ANGULAR \pm 3 °	
DRAFT WHERE APPLICABLE MUST REMAIN WITHIN DIMENSIONS	

DIMENSION STYLE	
MM ONLY	
DRAWN BY	DATE
CTEH	2008/01/30
CHECKED BY	DATE
CGTAN	2008/04/07
APPROVED BY	DATE
SHLENI	2008/04/08
MATERIAL NO.	
SEE TABLE	
SIZE	
A3	

SCALE	DESIGN UNITS	THIRD ANGLE PROJECTION
NTS	METRIC	
TITLE		
DDR3 DIMM, 100MM PITCH 240 CKTS, 25 DEG, T/H		
MOLEX INCORPORATED		
DOCUMENT NO.	SHEET NO.	
SD-78373-001	2 OF 5	
THIS DRAWING CONTAINS INFORMATION THAT IS PROPRIETARY TO MOLEX INCORPORATED AND SHOULD NOT BE USED WITHOUT WRITTEN PERMISSION		

9 8 7 6 5 4 3 2 1

MODULE CARD
DDR3 DUAL IN-LINE MEMORY MODULE FAMILY 1.00MM CONTACT CENTERS
(JEDEC MO-269, ISSUE A, 12/05)

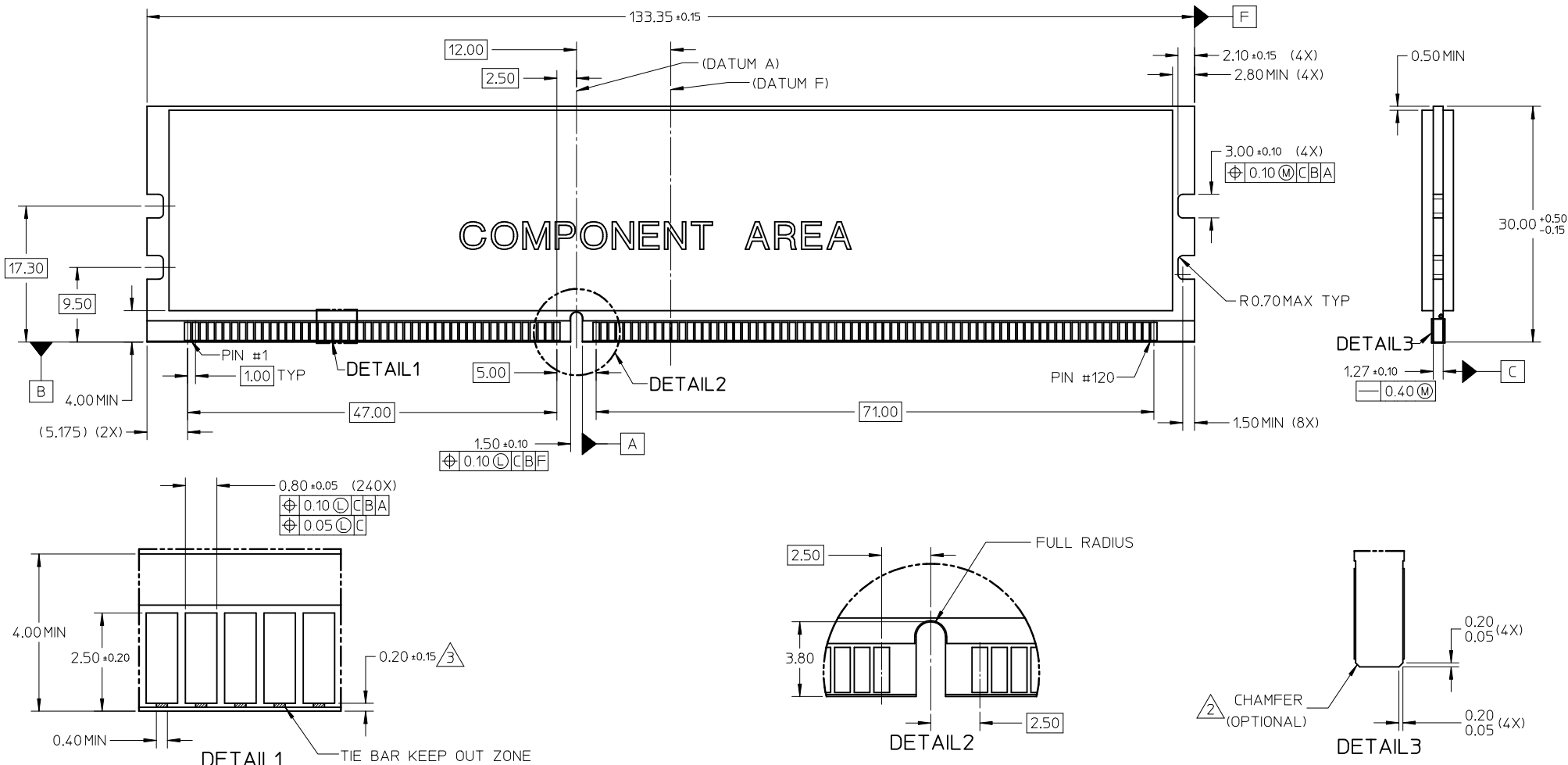

- NOTES:
- RECOMMENDED PLATING FOR CONTACT PADS:
 PREFERRED: 0.76 μM GOLD PLATING MIN
 OVER 2.00 μM NICKEL
 ALTERNATIVE: 0.05-0.75 μM GOLD PLATING
 OVER 2.00 μM NICKEL MUST
 USE AN ELECTRONIC CONTACT GRADE
 CORROSIVE BARRIER LUBRICANT
 - CHAMFER IS OPTIONAL AND IS NOT TO HIT THE GOLD PADS
 - LEADING EDGE OF GOLD PADS SPECIFIED BY KEEP OUT ZONE
 SHALL BE FREE OF BURRS AND EXTERNAL TIE BARS

ADDED CORING EC NO: S2010-0787 DRW: CCTEH 2010/03/22 CHKD: CGTAN 2011/01/24 APPR: SHLENI 2011/01/24	QUALITY SYMBOLS $\nabla_A = 0$ $\nabla_C = 0$ $\nabla_B = 0$	GENERAL TOLERANCES (UNLESS SPECIFIED) <table border="1"> <tr> <th></th> <th>mm</th> <th>INCH</th> </tr> <tr> <td>4 PLACES</td> <td>± ---</td> <td>± ---</td> </tr> <tr> <td>3 PLACES</td> <td>± ---</td> <td>± ---</td> </tr> <tr> <td>2 PLACES</td> <td>± 0.25</td> <td>± ---</td> </tr> <tr> <td>1 PLACE</td> <td>± ---</td> <td>± ---</td> </tr> </table>		mm	INCH	4 PLACES	± ---	± ---	3 PLACES	± ---	± ---	2 PLACES	± 0.25	± ---	1 PLACE	± ---	± ---	DIMENSION STYLE MM ONLY	SCALE NTS	DESIGN UNITS METRIC	THIRD ANGLE PROJECTION
		mm	INCH																		
	4 PLACES	± ---	± ---																		
	3 PLACES	± ---	± ---																		
2 PLACES	± 0.25	± ---																			
1 PLACE	± ---	± ---																			
		DRAWN BY: CCTEH CHECKED BY: CGTAN APPROVED BY: SHLENI	DATE: 2008/01/30 DATE: 2008/04/07 DATE: 2008/04/08	TITLE DDR3 DIMM, 100MM PITCH 240 CKTS, 25 DEG, T/H																	
		MATERIAL NO. SEE TABLE	MOLEX INCORPORATED																		
		DRAFT WHERE APPLICABLE MUST REMAIN WITHIN DIMENSIONS	DOCUMENT NO. SD-78373-001		SHEET NO. 3 OF 5																

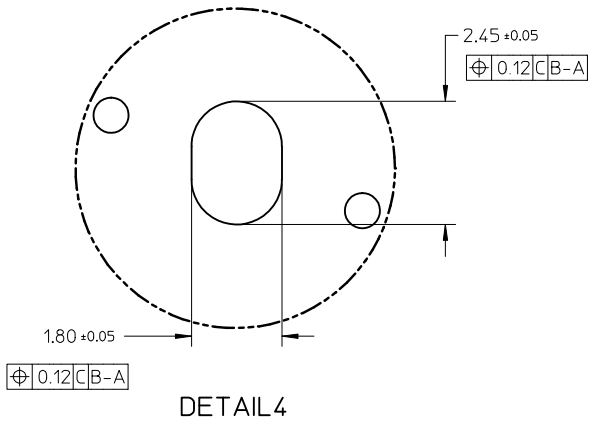
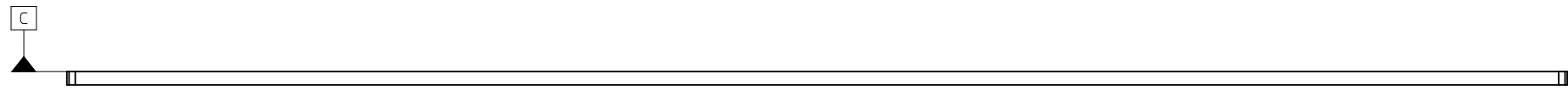
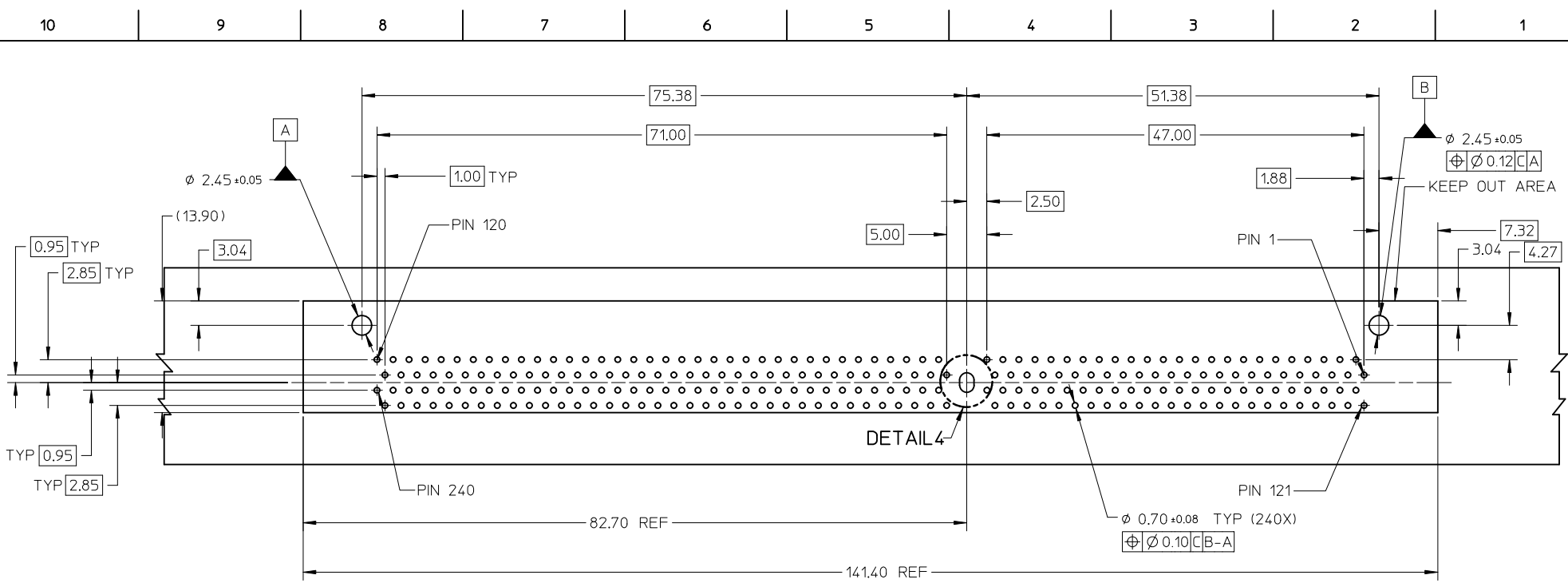

ADDED CORING EC NO: S2010-0787 DRWN: CCTEH 2010/03/22 CHKD: CGTAN 2011/01/24 APPR: SHLENI 2011/01/24	QUALITY SYMBOLS $F_A=0$ $F_G=0$ $F_P=0$	GENERAL TOLERANCES (UNLESS SPECIFIED) <table border="1"> <thead> <tr> <th></th> <th>mm</th> <th>INCH</th> </tr> </thead> <tbody> <tr> <td>4 PLACES</td> <td>± ---</td> <td>± ---</td> </tr> <tr> <td>3 PLACES</td> <td>± ---</td> <td>± ---</td> </tr> <tr> <td>2 PLACES</td> <td>± 0.25</td> <td>± ---</td> </tr> <tr> <td>1 PLACE</td> <td>± ---</td> <td>± ---</td> </tr> </tbody> </table>		mm	INCH	4 PLACES	± ---	± ---	3 PLACES	± ---	± ---	2 PLACES	± 0.25	± ---	1 PLACE	± ---	± ---	DIMENSION STYLE MM ONLY	SCALE NTS	DESIGN UNITS METRIC	THIRD ANGLE PROJECTION
		mm	INCH																		
	4 PLACES	± ---	± ---																		
	3 PLACES	± ---	± ---																		
2 PLACES	± 0.25	± ---																			
1 PLACE	± ---	± ---																			
DESCRIPTION DDR3 DIMM, 100MM PITCH 240 CKTS, 25 DEG, T/H	DRAWN BY CCTEH	DATE 2008/01/30	TITLE DDR3 DIMM, 100MM PITCH 240 CKTS, 25 DEG, T/H	MOLEX INCORPORATED																	
MATERIAL NO.	APPROVED BY SHLENI	DATE 2008/04/08	DOCUMENT NO. SD-78373-001	SHEET NO. 4 OF 5																	
DRAFT WHERE APPLICABLE MUST REMAIN WITHIN DIMENSIONS	SIZE A3	THIS DRAWING CONTAINS INFORMATION THAT IS PROPRIETARY TO MOLEX INCORPORATED AND SHOULD NOT BE USED WITHOUT WRITTEN PERMISSION																			

PART NO.	VOLTAGE KEY	DIM 'P'	DIM 'Q'	RECOMMENDED PCB THICKNESS	PLATING OPTION
78373-0001	CENTER (1.5V)	2.79	3.18	1.57	0.76µM / 30 Mmch MIN GOLD ON CONTACT 2.54µM / 100 Mmch MIN PURE TIN ON SOLDER TAILS 1.27µM / 50 Mmch MIN NICKEL UNDERPLATE
78373-0011		3.18	4.83	2.36	
78373-0111		4.00	4.83	2.59	

ADDED CORING EC NO: S2010-0787 DRW: CCTEH 2010/03/22 CHK: CGTAN 2011/01/24 APPR: SHLENI 2011/01/24	DESCRIPTION REV	QUALITY SYMBOLS	GENERAL TOLERANCES (UNLESS SPECIFIED)	DIMENSION STYLE MM ONLY	SCALE NTS	DESIGN UNITS METRIC	THIRD ANGLE PROJECTION																																
		$\nabla_A = 0$ $\nabla_C = 0$ $\nabla_P = 0$	<table border="1"> <tr> <th></th> <th>mm</th> <th>INCH</th> </tr> <tr> <td>4 PLACES</td> <td>± ---</td> <td>± ---</td> </tr> <tr> <td>3 PLACES</td> <td>± ---</td> <td>± ---</td> </tr> <tr> <td>2 PLACES</td> <td>± 0.25</td> <td>± ---</td> </tr> <tr> <td>1 PLACE</td> <td>± ---</td> <td>± ---</td> </tr> </table>		mm	INCH	4 PLACES	± ---	± ---	3 PLACES	± ---	± ---	2 PLACES	± 0.25	± ---	1 PLACE	± ---	± ---	<table border="1"> <tr> <th>DRAWN BY</th> <th>DATE</th> <th>TITLE</th> </tr> <tr> <td>CCTEH</td> <td>2008/01/30</td> <td rowspan="2">DDR3 DIMM, 100MM PITCH 240 CKTS, 25 DEG, T/H</td> </tr> <tr> <th>CHECKED BY</th> <th>DATE</th> </tr> <tr> <td>CGTAN</td> <td>2008/04/07</td> <td></td> </tr> <tr> <th>APPROVED BY</th> <th>DATE</th> <td></td> </tr> <tr> <td>SHLENI</td> <td>2008/04/08</td> <td></td> </tr> </table>	DRAWN BY	DATE	TITLE	CCTEH	2008/01/30	DDR3 DIMM, 100MM PITCH 240 CKTS, 25 DEG, T/H	CHECKED BY	DATE	CGTAN	2008/04/07		APPROVED BY	DATE		SHLENI	2008/04/08				MOLEX INCORPORATED
			mm	INCH																																			
		4 PLACES	± ---	± ---																																			
3 PLACES	± ---	± ---																																					
2 PLACES	± 0.25	± ---																																					
1 PLACE	± ---	± ---																																					
DRAWN BY	DATE	TITLE																																					
CCTEH	2008/01/30	DDR3 DIMM, 100MM PITCH 240 CKTS, 25 DEG, T/H																																					
CHECKED BY	DATE																																						
CGTAN	2008/04/07																																						
APPROVED BY	DATE																																						
SHLENI	2008/04/08																																						
		DRAFT WHERE APPLICABLE MUST REMAIN WITHIN DIMENSIONS	MATERIAL NO. SEE TABLE	DOCUMENT NO. SD-78373-001	SHEET NO. 5 OF 5																																		
			SIZE A3	THIS DRAWING CONTAINS INFORMATION THAT IS PROPRIETARY TO MOLEX INCORPORATED AND SHOULD NOT BE USED WITHOUT WRITTEN PERMISSION																																			