

THIS DRAWING IS UNPUBLISHED. RELEASED FOR PUBLICATION
 © COPYRIGHT 2010 BY TYCO ELECTRONICS CORPORATION. ALL RIGHTS RESERVED.

LOC	DIST	REVISIONS					
DW	-	P	LTR	DESCRIPTION	DATE	DWN	APVD
		HI		OBsolete PARTS	08JAN16	H.X	W.H

NOTES:

- MATERIAL:
 HOUSING: LCP WITH 30% GF, UL94 V-0, NATURAL COLOR.
 ACTUATOR: LCP WITH 40% GF, UL94 V-0, BLACK COLOR.
 CONTACTS: PHOSPHOR BRONZE.
 PEGS: BRASS.
- FINISH:
 CONTACTS: 0.0762µm [3µ"] MIN. GOLD PLATED ON CONTACT AREA, GOLD FLASH ON SOLDER TAIL, WITH ENTIRE CONTACT UNDERPLATED 1.27µm [50µ"] MIN. NICKEL.
 PEGS: 2.54µm [100µ"] MIN. MATTE-TIN OVER 1.27µm [50µ"] MIN. NICKEL
- REFLOW SOLDER CAPABLE TO 260°C PER TEC-109-201, CONDITION B.
- SUBSTANCE RESTRICTIONS FOR LOW HALOGEN (BY WEIGHT):
 - BROMINE (Br) ≤ 900 PPM (0.09%)
 - CHLORINE (Cl) ≤ 900 PPM (0.09%)
 - TOTAL CONCENTRATION OF CHLORINE (Cl) + BROMINE (Br) ≤ 1500 PPM (0.15%)

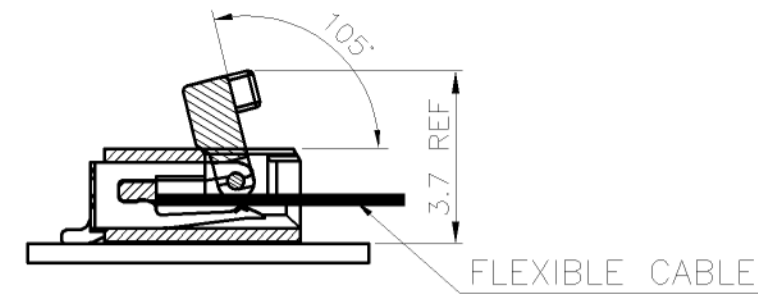
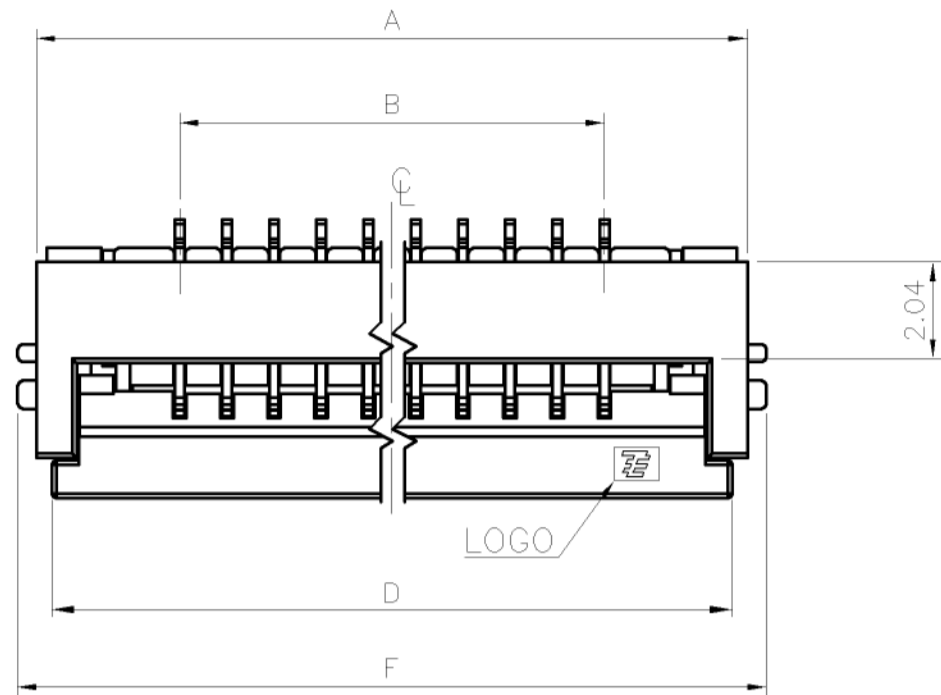

OPEN STATUS

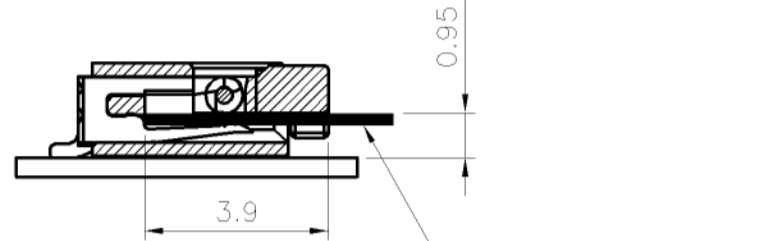

CLOSE STATUS

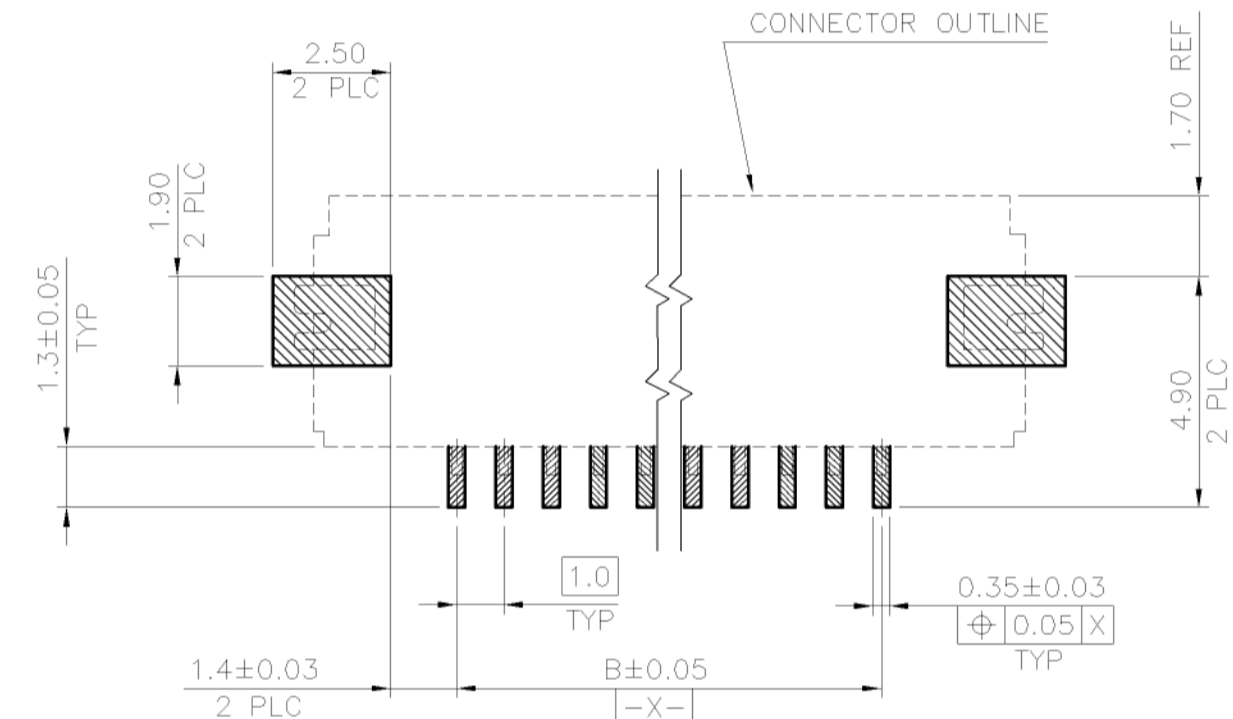
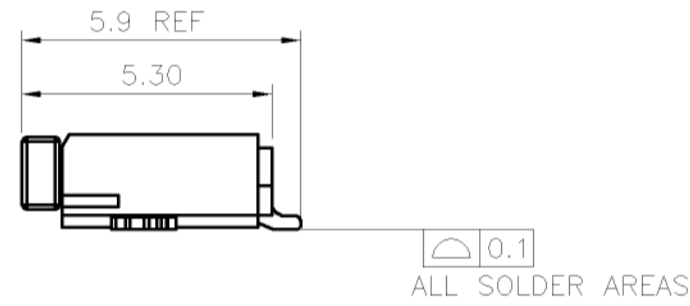
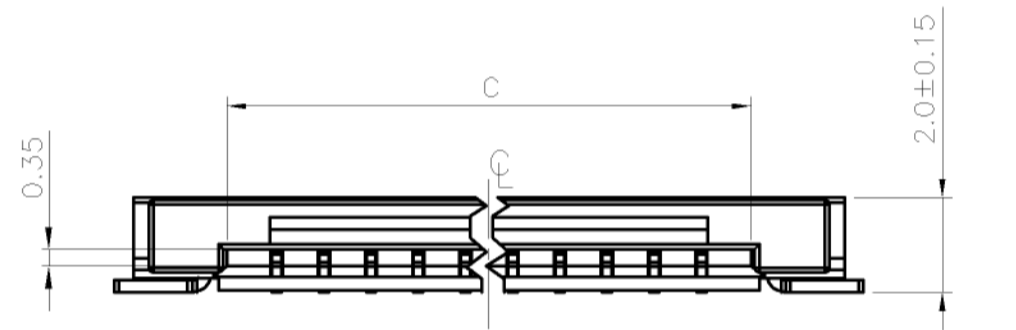

TOLERANCE: ±0.08
RECOMMENDED P.C.B. LAYOUT (TOP VIEW)

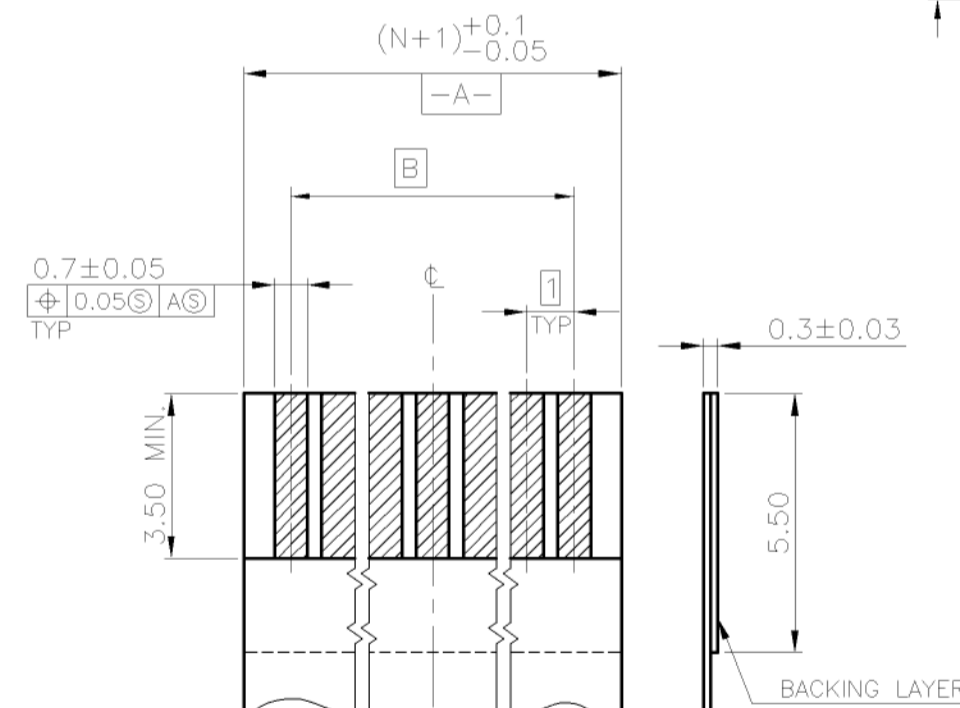
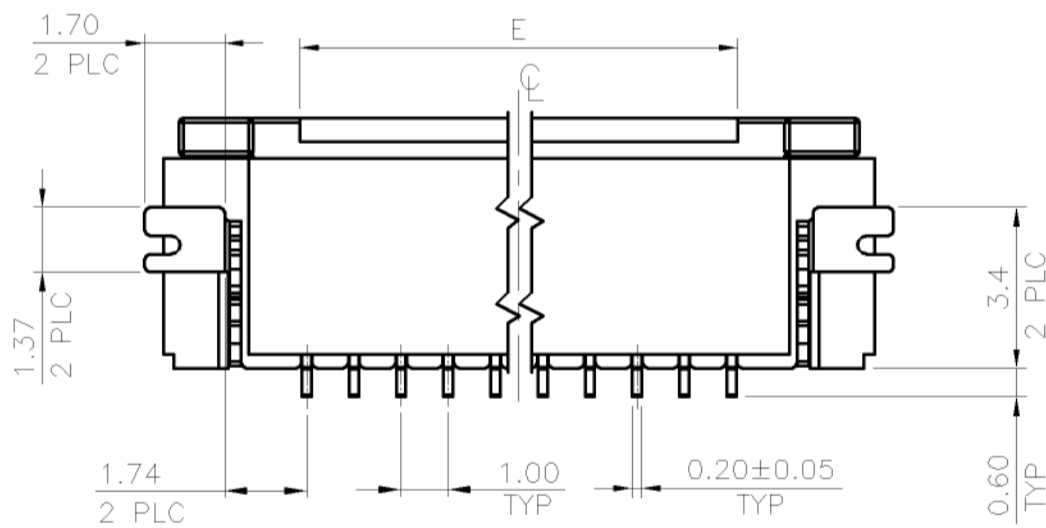

(N = NO. OF CONTACTS)
RECOMMENDED FPC/FFC LAYOUT

OBsolete

35.87	7.0	34.41	31.10	29.0	35.07	30	3-2041084-0
30.87	7.0	29.41	26.10	24.0	30.07	25	2-2041084-5
21.87	7.0	20.41	17.10	15.0	21.07	16	1-2041084-6
17.87	11.28	16.41	13.10	11.0	17.07	12	1-2041084-2
15.87	9.28	14.41	11.10	9.0	15.07	10	1-2041084-0
13.87	7.28	12.41	9.10	7.0	13.07	8	2041084-8
11.87	5.28	10.41	7.10	5.0	11.07	6	2041084-6
9.87	3.28	8.41	5.10	3.0	9.07	4	2041084-4
F	E	D	C	B	A	NO. OF CONTACTS	PART NUMBER

THIS DRAWING IS A CONTROLLED DOCUMENT.		DWN A. WU 07AUG2008	Tyco Electronics Corporation Taipei, Taiwan	
DIMENSIONS: MM		CHK S. HOU 07AUG2008	NAME	
TOLERANCES UNLESS OTHERWISE SPECIFIED:		APVD W. KODAMA 07AUG2008	PRODUCT SPEC	
0 PLC ± -		108-57365		
1 PLC ± 0.3		APPLICATION SPEC		
2 PLC ± 0.2		WEIGHT -		
3 PLC ± -		SIZE A2		
4 PLC ± -		CAGE CODE 00779		
ANGLES ± 3'		DRAWING NO C=2041084		
MATERIAL SEE NOTE		RESTRICTED TO -		
FINISH SEE NOTE		SCALE -		
CUSTOMER DRAWING		SHEET 1 of 2		
		REV HI		

THIS DRAWING IS UNPUBLISHED. RELEASED FOR PUBLICATION
 © COPYRIGHT 2010 BY TYCO ELECTRONICS CORPORATION. ALL RIGHTS RESERVED.

LOC	DIST	REVISIONS			
P	LTR	DESCRIPTION	DATE	DWN	APVD
DW	-	SEE SHEET 1.			

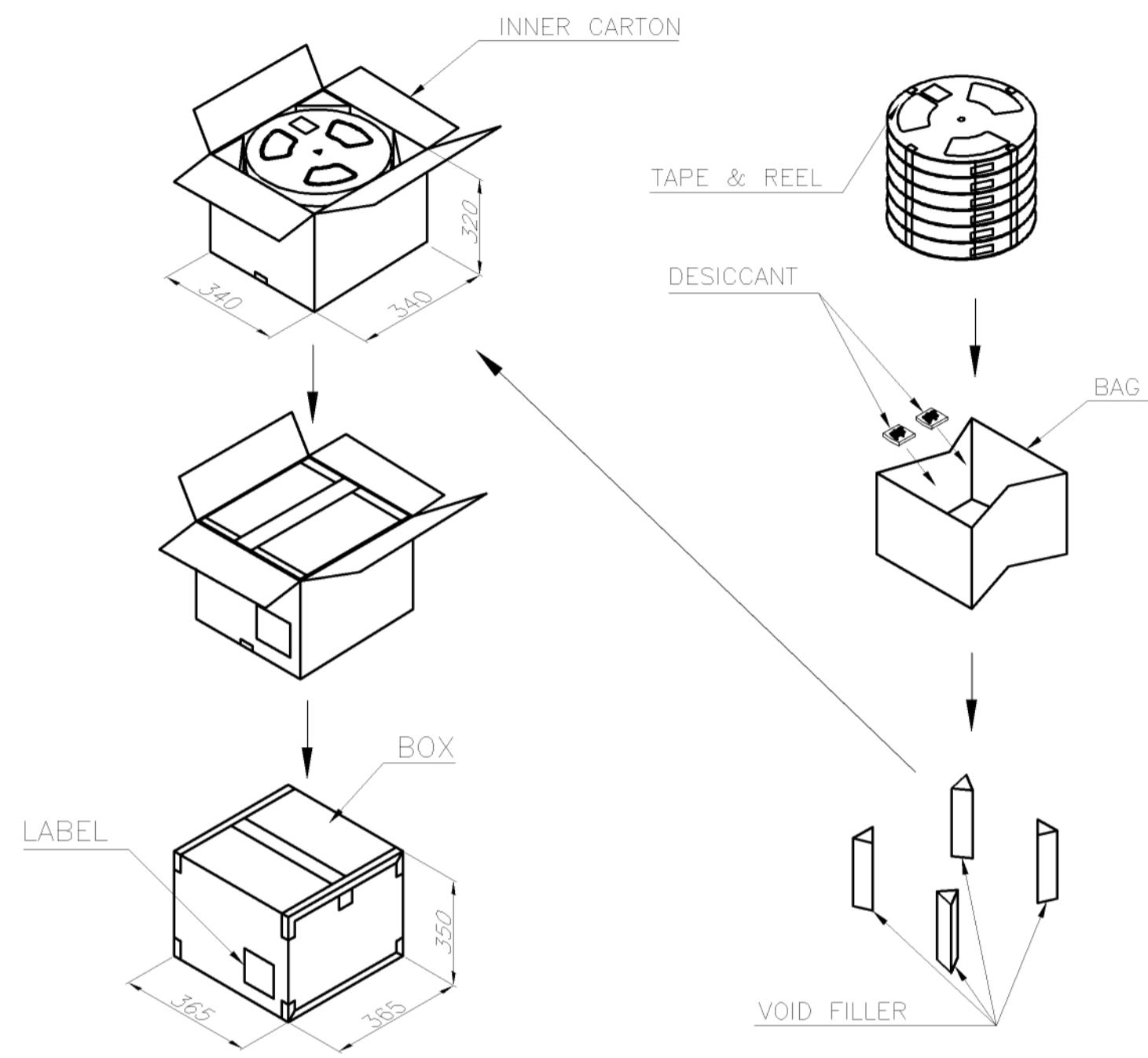
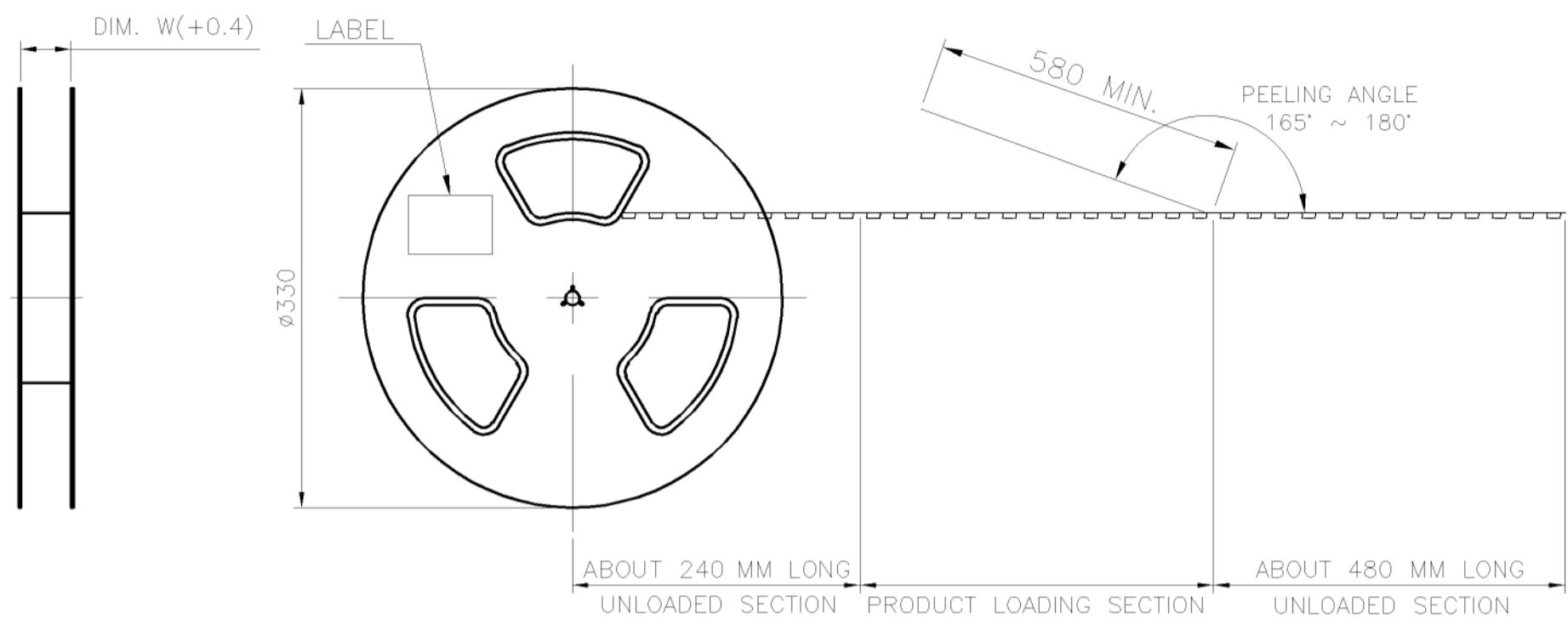

USER DIRECTION OF UNREELING →

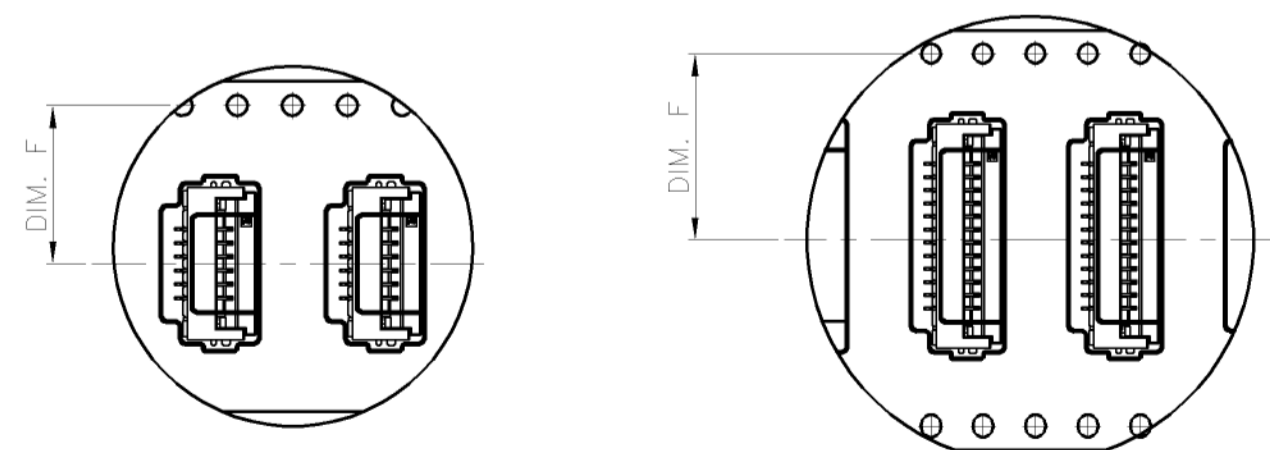
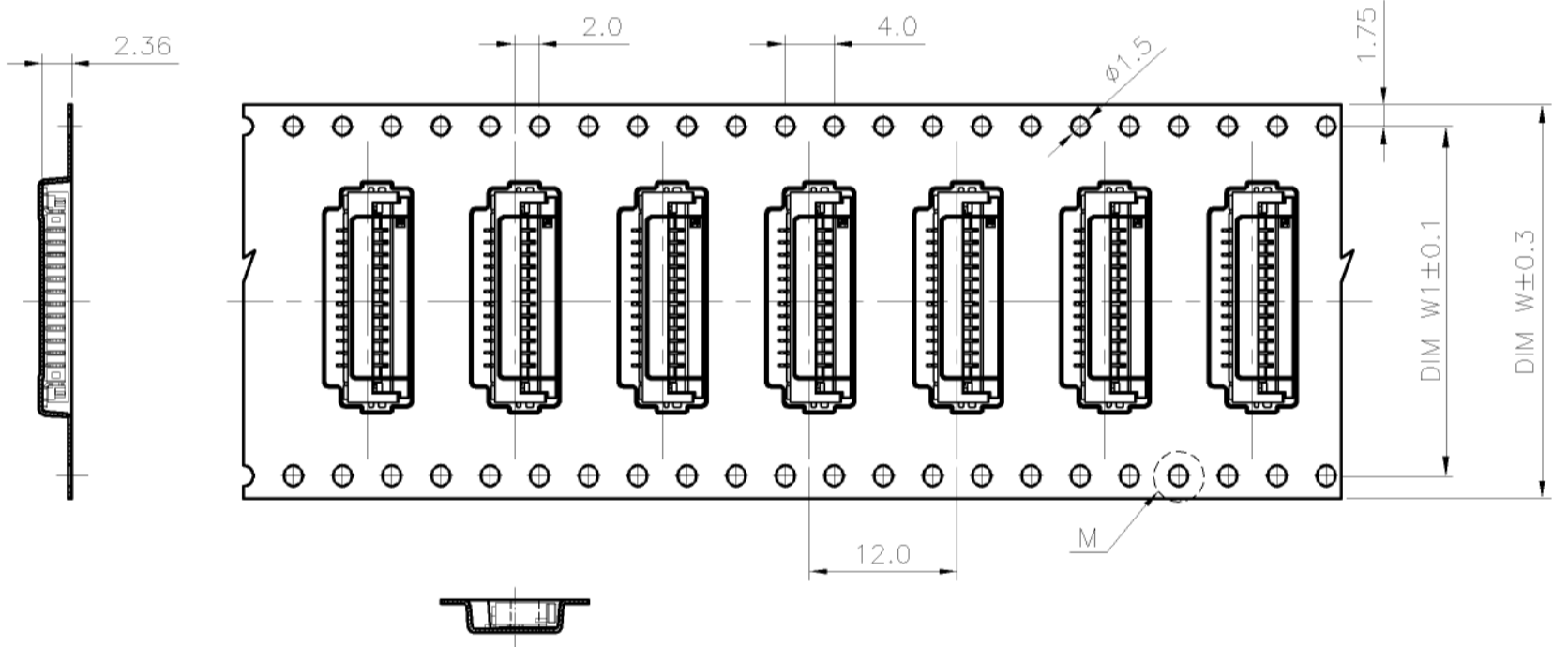

DETAIL M
SCALE 2:1

PCS/BOX	PCS/TAPE	REELS/BOX	DIM W1	DIM F	DIM W	G/W (Kg)	N/W (Kg)	NO. OF CONTACT
10000	2000	5	52.4	36.2	56	12.25	5.3	30
12000	2000	6	40.4	20.2	44	13.61	6.3	25
16000	2000	8	28.4	14.2	32	11.62	5.02	16
						10.8	4.2	12
						10.35	4.3	10
20000	2000	10	-	11.5	24	10.21	3.86	8
						10.1	3.15	6
						9.9	2.75	4

THIS DRAWING IS A CONTROLLED DOCUMENT.		DWN A. WU 07AUG2008	Tyco Electronics Corporation Taipei, Taiwan	
DIMENSIONS: MM		CHK S. HOU 07AUG2008	NAME	
TOLERANCES UNLESS OTHERWISE SPECIFIED:		APVD W. KODAMA 07AUG2008	FPC CONNECTOR, 1.0 PITCH, 105° ZIF, BOTTOM CONTACT	
0 PLC ± -		PRODUCT SPEC	SIZE	RESTRICTED TO
1 PLC ± -		APPLICATION SPEC	CAGE CODE	
2 PLC ± -		WEIGHT	DRAWING NO	
3 PLC ± -		CUSTOMER DRAWING	A2 00779	
4 PLC ± -		SCALE	C=2041084	
ANGLES ± -		SHEET	2 of 2	
FINISH		REV	H1	