

REVISIONS					
P	LTR	DESCRIPTION	DATE	DWN	APVD
A		ECO-18-017212	30NOV2018	FL	HL

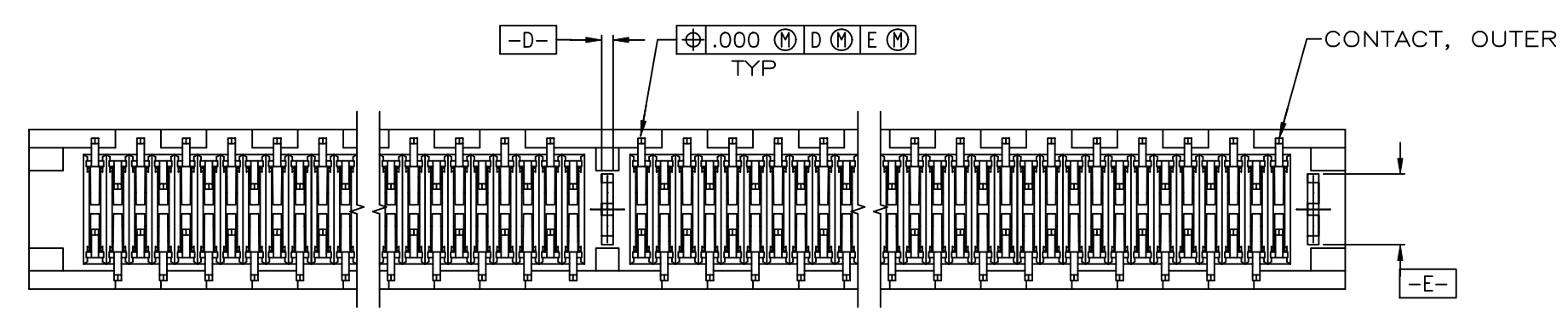

SEE SHEET 2 FOR HOLE PATTERN

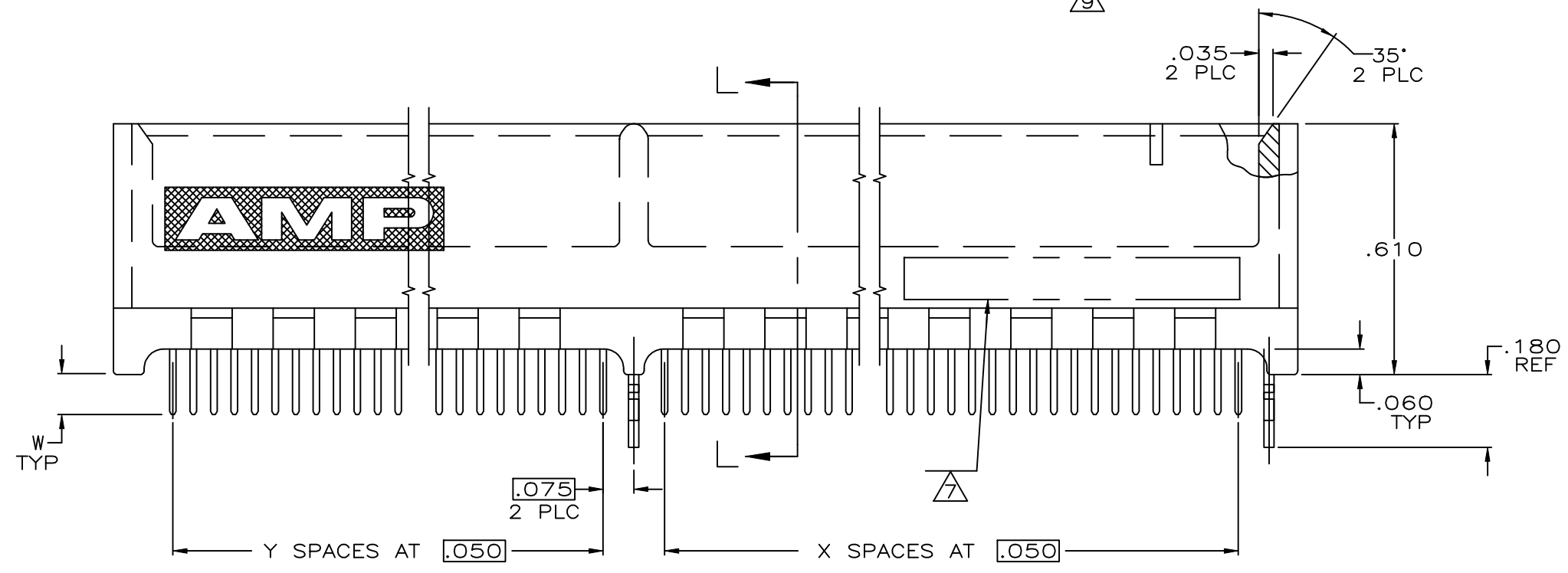
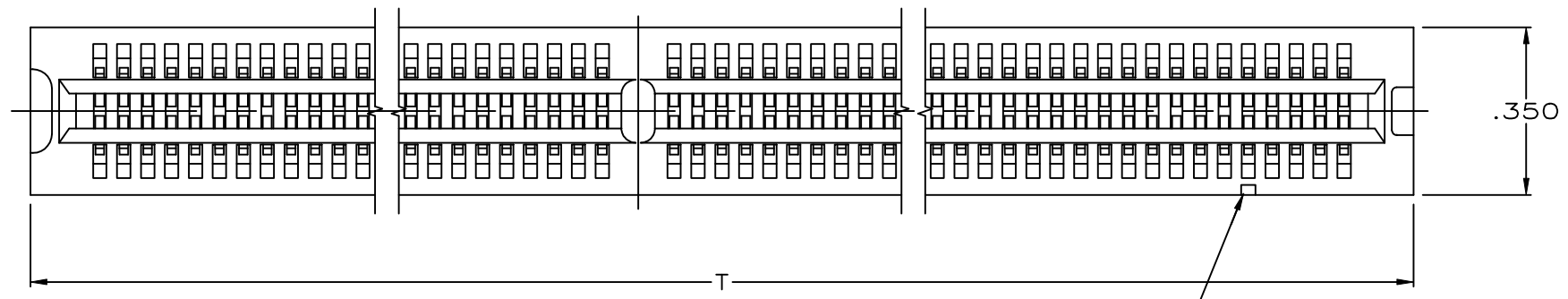
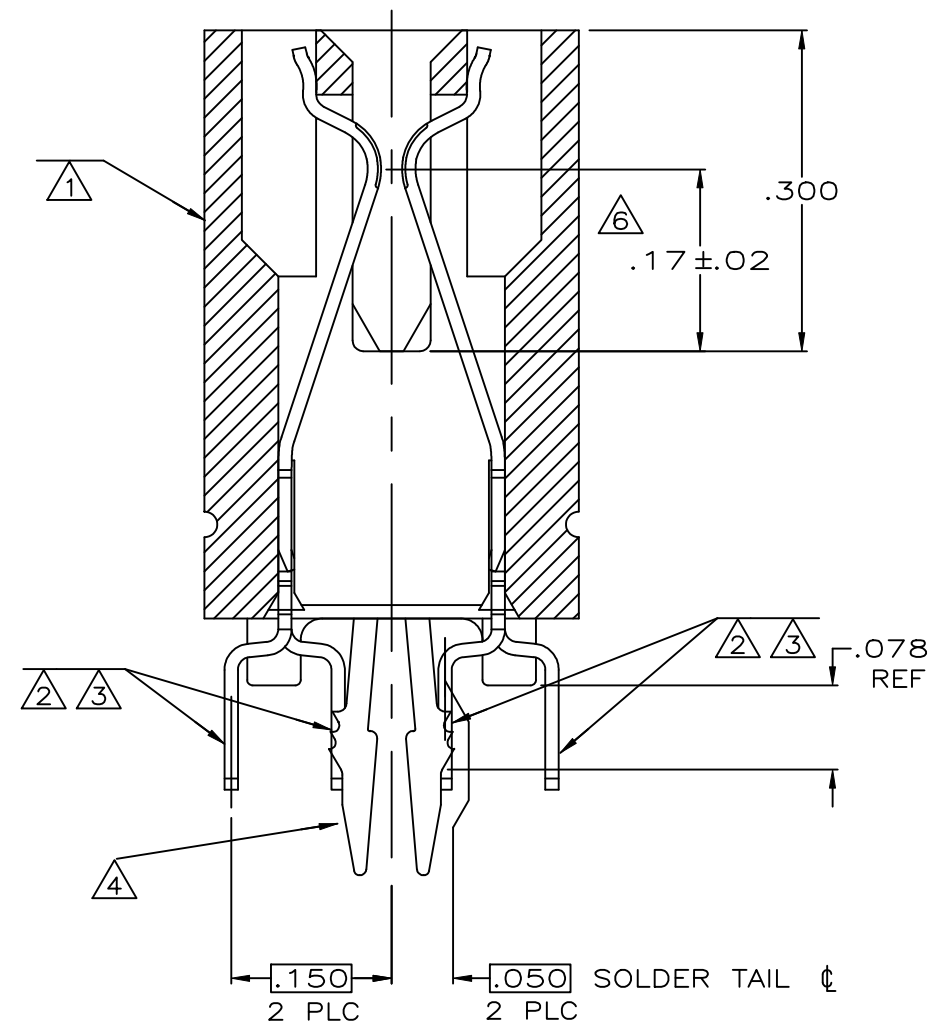

- 1 HOUSING: HIGH TEMPERATURE THERMOPLASTIC. COLOR: BROWN.
- 2 CONTACT: PHOSPHOR BRONZE.
- 3 CONTACT FINISH: .000050 MIN NICKEL ALL OVER. .000030 MIN GOLD OVER NICKEL IN CONTACT AREA. .000100 MIN MATTE TIN OVER NICKEL ON SOLDER TAILS.
- 4 METAL HOLD DOWN: BRASS
- 5 METAL HOLD DOWN FINISH: .000050 MIN NICKEL ALL OVER, .000150 MIN MATTE TIN ALL OVER
- 6 DISTANCE FROM CONTACT POINT TO BOTTOM OF CARD SLOT.
- 7 AMP PART NUMBER, DATE CODE AND CSA LOGO MARKED IN APPROXIMATE AREA SHOWN.
- 8 DISTANCE FROM CONTACT POINT TO BOTTOM OF CARD SLOT.
- 9 PIN ONE IDENTIFIER NOTCH ONLY ON PART NUMBERS INDICATED.
- 10 OBSOLETE PARTS: OBSOLETE CIS STREAMLINING PER D.RENAUD/D.SINISI

10 OBSOLETE	.125	YES	B	2.350	2.310	3.14	.610	10	44	56	5145020-8
	.140	YES	A	2.550	2.510	4.89	2.160	41	48	91	5145020-7
	.125	YES	A	2.550	2.510	4.89	2.160	41	48	91	5145020-6
	.125	NO	D	1.800	1.760	2.59	.610	10	33	45	5145020-5

THIS DRAWING IS A CONTROLLED DOCUMENT.		DWN AL FRANTUM 02 AUG 05		APVD AL FRANTUM 02 AUG 05		NAME		TE Connectivity Ltd.	
DIMENSIONS: INCHES		TOLERANCES UNLESS OTHERWISE SPECIFIED:		PRODUCT SPEC 108-14034		APPLICATION SPEC 114-26012		SIZE CAGE CODE DRAWING NO. A1 00779 C=5145020	
MATERIAL		FINISH		WEIGHT		CUSTOMER DRAWING		SCALE 4:1 SHEET 1 OF 2 REV A	

THIS DRAWING IS UNPUBLISHED. RELEASED FOR PUBLICATION
 © COPYRIGHT - TE Connectivity Ltd. ALL RIGHTS RESERVED.

REVISIONS				
P	LTR	DESCRIPTION	DATE	OWN APVD
-	-	SEE SHEET 1	-	-

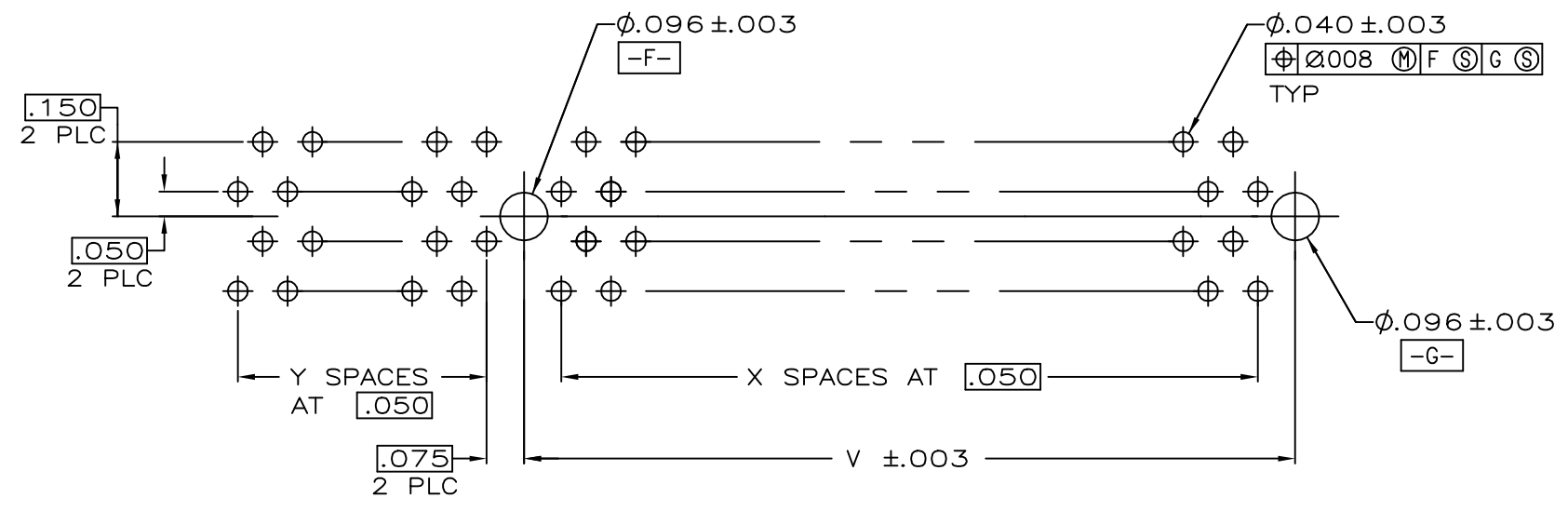

RECOMMENDED CONNECTOR MOUNTING HOLE PATTERN A
 (CONNECTOR SIDE SHOWN)

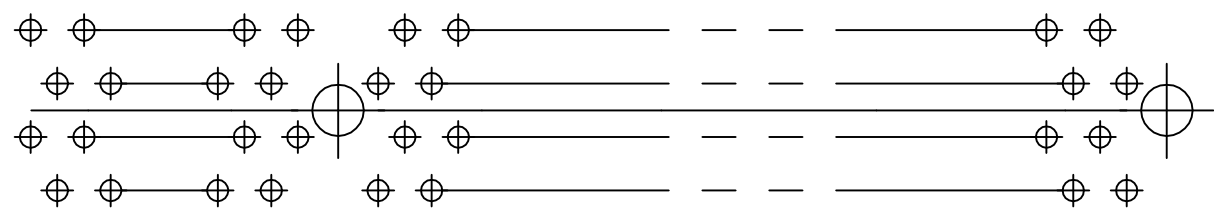

RECOMMENDED CONNECTOR MOUNTING HOLE PATTERN B
 (CONNECTOR SIDE SHOWN)

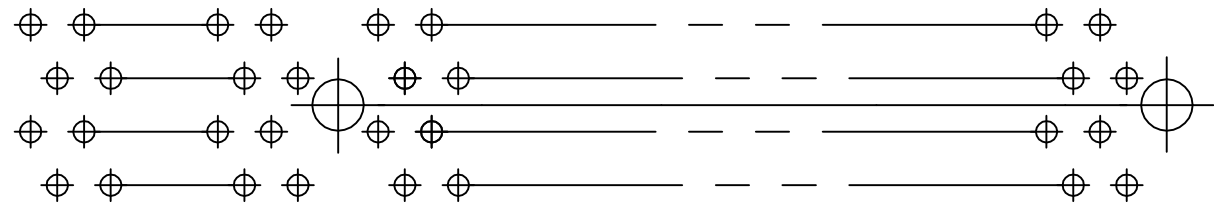

RECOMMENDED CONNECTOR MOUNTING HOLE PATTERN C
 (CONNECTOR SIDE SHOWN)

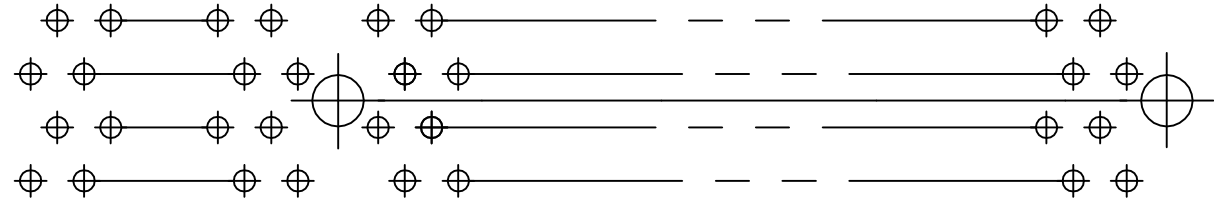

RECOMMENDED CONNECTOR MOUNTING HOLE PATTERN D
 (CONNECTOR SIDE SHOWN)

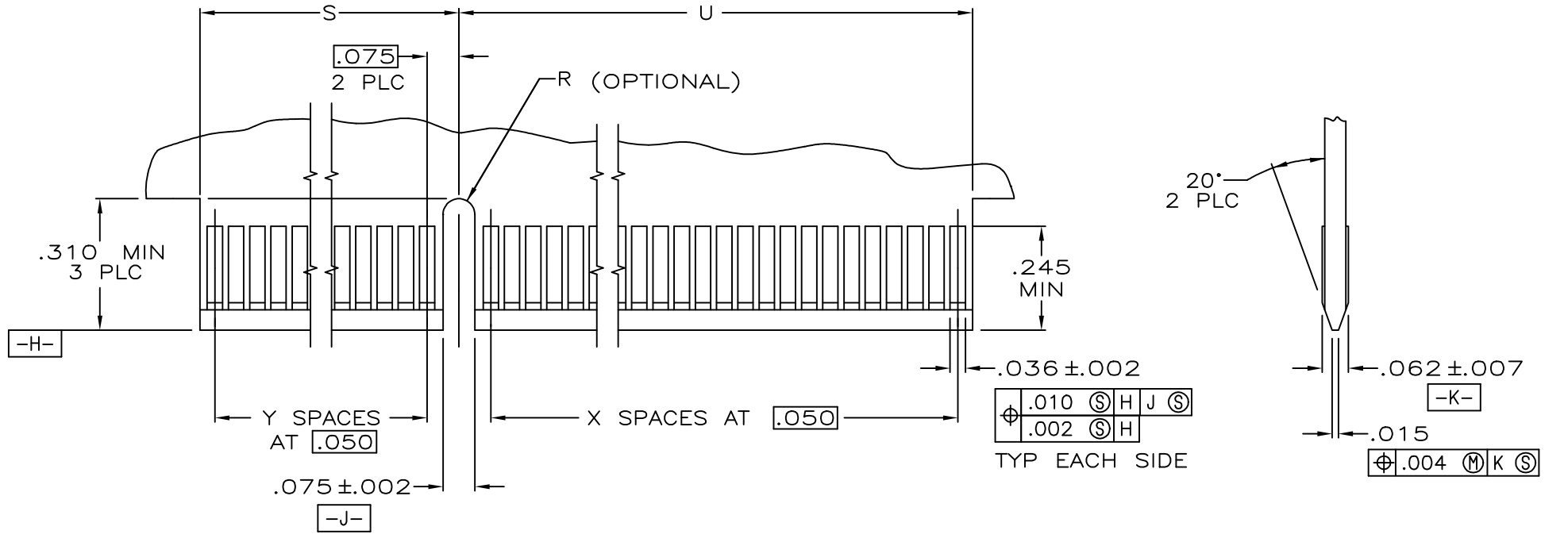

RECOMMENDED MATING BOARD EDGE CONFIGURATION

THIS DRAWING IS A CONTROLLED DOCUMENT.		OWN AL FRANTUM 02 AUG 05	TE Connectivity Ltd.	
		CHK AL FRANTUM 02 AUG 05		
DIMENSIONS: INCHES		TOLERANCES UNLESS OTHERWISE SPECIFIED:		NAME
		0 PLC ± - 1 PLC ± - 2 PLC ± .01 3 PLC ± .005 4 PLC ± - ANGLES ± °		PRODUCT SPEC 108-14034 APPLICATION SPEC 114-26012
MATERIAL SEE SHEET 1		FINISH SEE SHEET 1		SIZE CAGE CODE DRAWING NO A1 00779 C=5145020 RESTRICTED TO
		CUSTOMER DRAWING		SCALE 4:1 SHEET 2 OF 2 REV A