

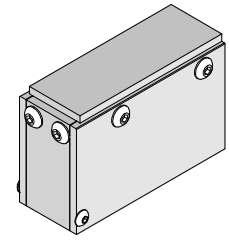

**2-by-1
zQSFP+
Insertion Tool**

**Application Tooling
Specification Sheet**



Order No. 62202-5250

FEATURES

- Lightweight tool used in the insertion of a zQSFP+ connector in a PCB
- Inserts connector to a PCB without damage to the board
- Use tool 62202-5210 for removing connectors

SCOPE

Products: Quad Small Form-factor Pluggable zQSFP+ Cage Assembly, 2-by 1 Thermal Multi-Port Connector, 2 Press Fit Rear Legs, Elastomeric Gasket for SAN Applications.

Series No.	Connector Order No.			
170879	170879-1001	170879-1002	170879-1003	170879-1010

Notes:

1. See the following pages for tooling operation instructions.
2. These tools require a "Keep Out Zone" around the connector free of components. The rear of the connector should be .197" (5.0mm). The right and left sides should be .14" (3.5mm). See Figure 1.

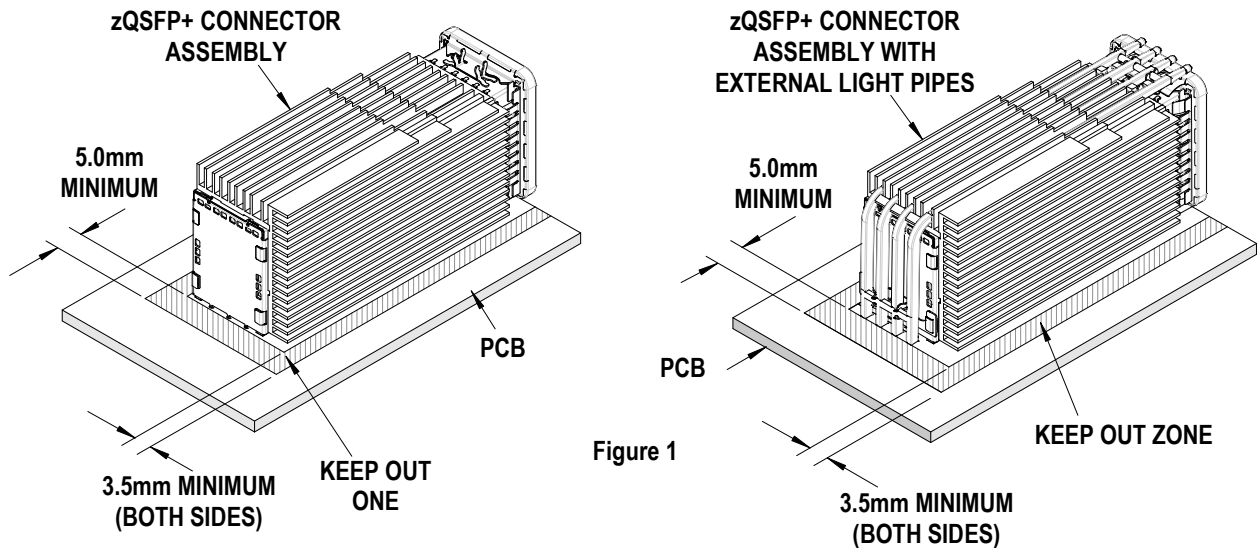

Figure 1

Description

The following Instructions are used for inserting the 2 by 1 connector into a PCB.

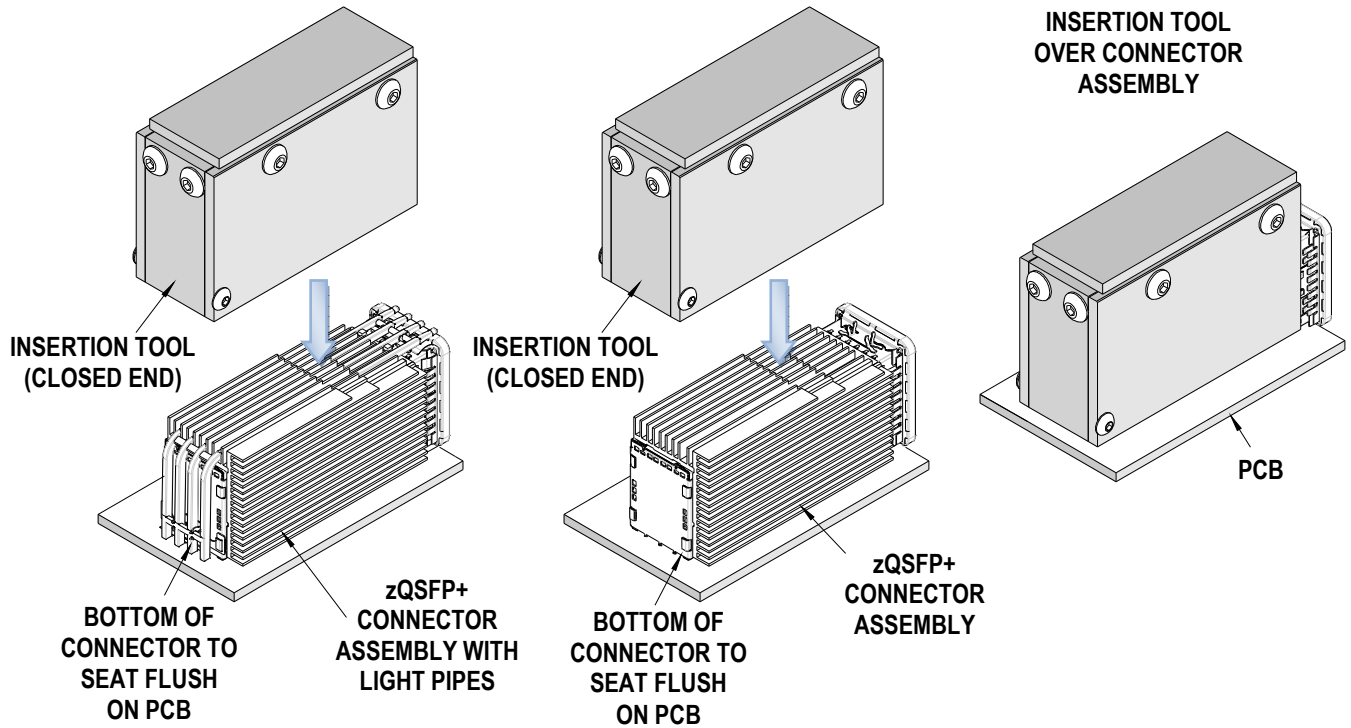

Figure 2

Operation

1. Place a connector assembly on the PCB.
2. Place the tool on the connector assembly (closed end to the back end of the connector). See Figure 2.
3. Place tool, connector, and PCB, in a press of suitable size and force, and seat the connector assembly as shown. The support plate (furnished by the customer) under the PCB must have clearance for the connector pins as they pass through the PCB.

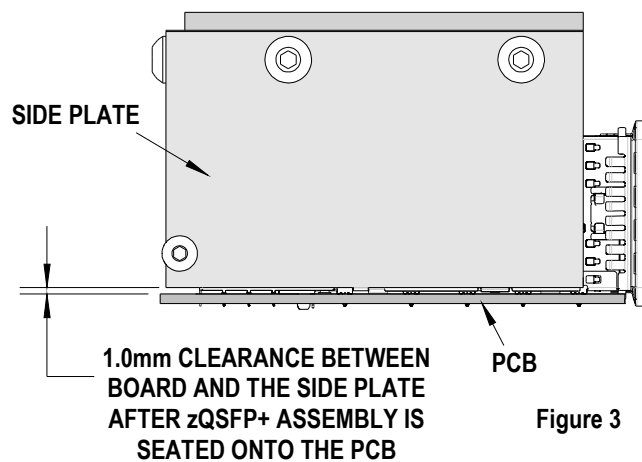

Figure 3

Clearance

Use this tool only with a press that has a pre-determined shut height when seating a QSFP Assembly on a PCB. See figure 3. Allowing the Press-In Tool to stop on the board will result in damage the QSFP cage and terminals being over seated.

CAUTION: Molex application tooling specifications are valid only when used with Molex connectors and tooling.

Contact Information

For more information on Molex application tooling please contact Molex at 1-800-786-6539.

Visit our Web site at <http://www.molex.com>