



Electrical specifications

Cut-off Frequency: 1000 MHz
Passband: DC-1000 MHz
Insertion loss: 0.6 dB Max.
Return loss: 20 dB Min.
Rejection : 50 dB Min. @ 1420-4000 MHz
Power Handling: 200 Watts

Mechanical

Mounting Method: Through Holes
Connector Type: N-Type(F)
Dimensions: 4 x 1.25 x 0.75 Inches

Environmental

Operating Temperature: -40°C to +70°C
Storage Temperature: -55°C to +85° C
Shock: 10 G. 11ms
Vibration: 10 G. 5 to 200 Hz

Outline Drawing:

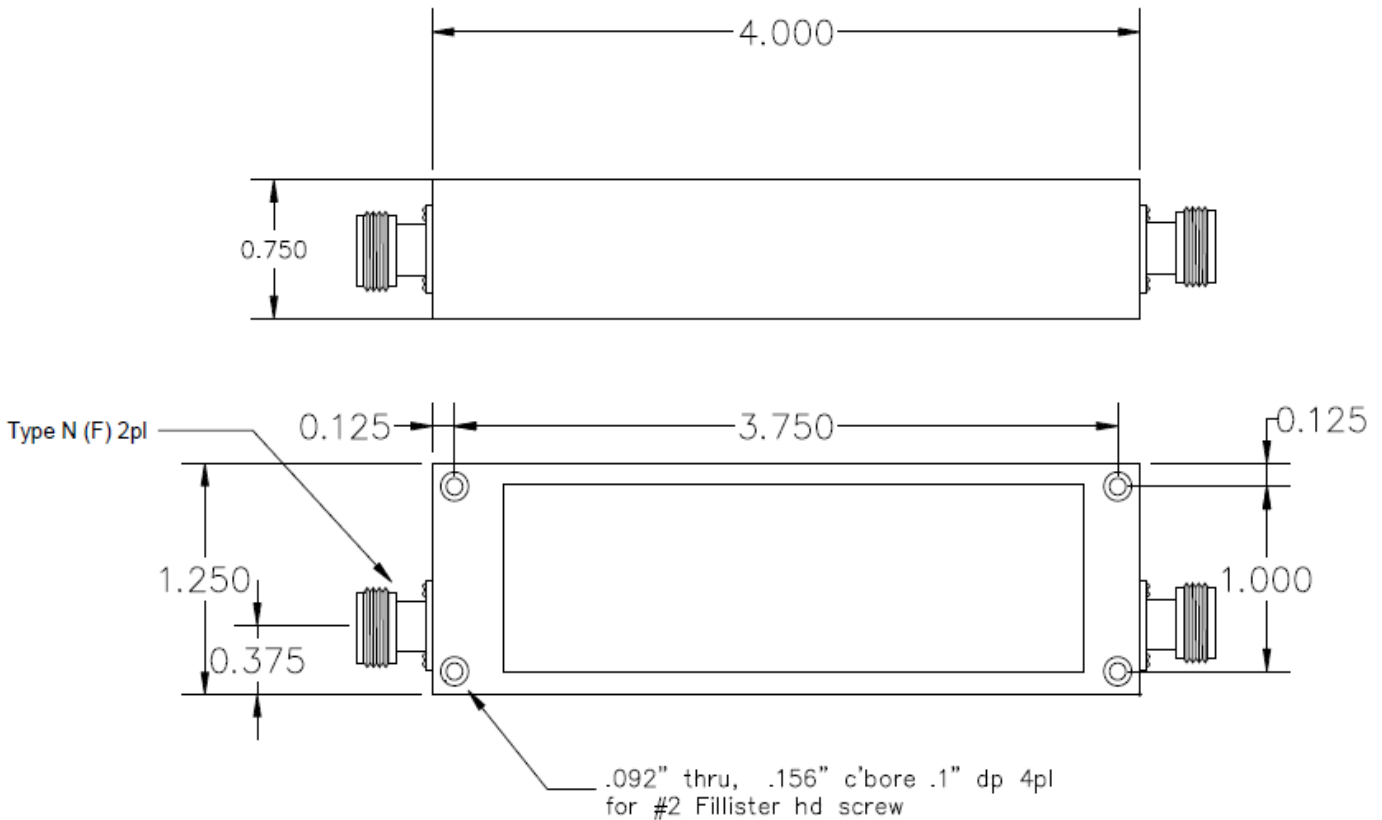

Tolerance: +/-0.01 inches [+/- 0.3mm]

Angles: +/- 1 Deg.

*Tolerance as shown unless otherwise specified in the datasheet electrical specification tables above.

*When max dimensions are called out the above tolerances do not apply as long as it is under the max call out.