

Angle Position Sensors



AN1 Sensors

Intrinsically Linear Angle Position Sensor

Description

The AN1 Series sensors are one-piece, intrinsically linear contact angle position sensors. The sensors operate through the use of Hall Effect technology with magnetic fields generated by permanent magnets. They provide a linear change in voltage output (ratiometric to the input voltage) corresponding to an angular rotation of the input shaft.

Features

- Patented intrinsically linear angle position sensor (ILAPS)
- Magnet/sensor orientation provides linear output from 5° to 85° of rotation without the need for electrical compensation
- Return spring provides resistance to CCW motion
- Fully encapsulated electronics
- RoHS compliant
- IP67

Typical Applications

- Implement (fork lift, agricultural trailer hitch, etc.) position sensing
- Steer, throttle by wire
- Gear selection
- Zero-contact encoder alternative

Environmental Specifications

Vibration	1g RMS axial, 5g RMS horizontal, 8g RMS vertical; 20 Hz to 2 kHz
Operating Temperature	-40 °C to 125 °C (-40 °F to 257 °F)
Storage Temperature	-40 °C to 135 °C (-40 °F to 275 °F)
Ingress Protection	IP67

Electrical Specifications

Input Voltage	5.0 VDC \pm 10%
Output Voltage vs. Rotation Angle	0° to 5° : 10% of Input Voltage, 5° to 85°: ratiometric (linear from 10% to 90% of Input Voltage), 85° to 120°: 90% of Input Voltage (see chart)
Input Current	8 mA @ 5 VDC
Output Current	-1.25 mA to 1.25 mA
Output Linearity	\pm 2%

Mechanical Specifications

Housing Material	Glass Reinforced Plastic
Mechanical Travel	120° maximum rotation
Rotation Torque	0.21 Nm (30 in•oz) max with return spring
Mass	24 g (0.85 oz)
Life	+10 million full cycles

Products

Part Number	Sensing Direction	Connector	Terminal	Housing
AN101101	Counter-clockwise	Delphi Metri-pack 150 12162185	Delphi 12124075	Delphi 12162185

www.switches-sensors.zf.com ZF Electronics Systems Pleasant Prairie, LLC ("ZF") acquired the rights to the CHERRY branded switches and sensors in 2008. Although ZF divested its interest in the CHERRY name in 2015, the switches and sensors remain unchanged and are now sold under the ZF brand.



Output Voltage

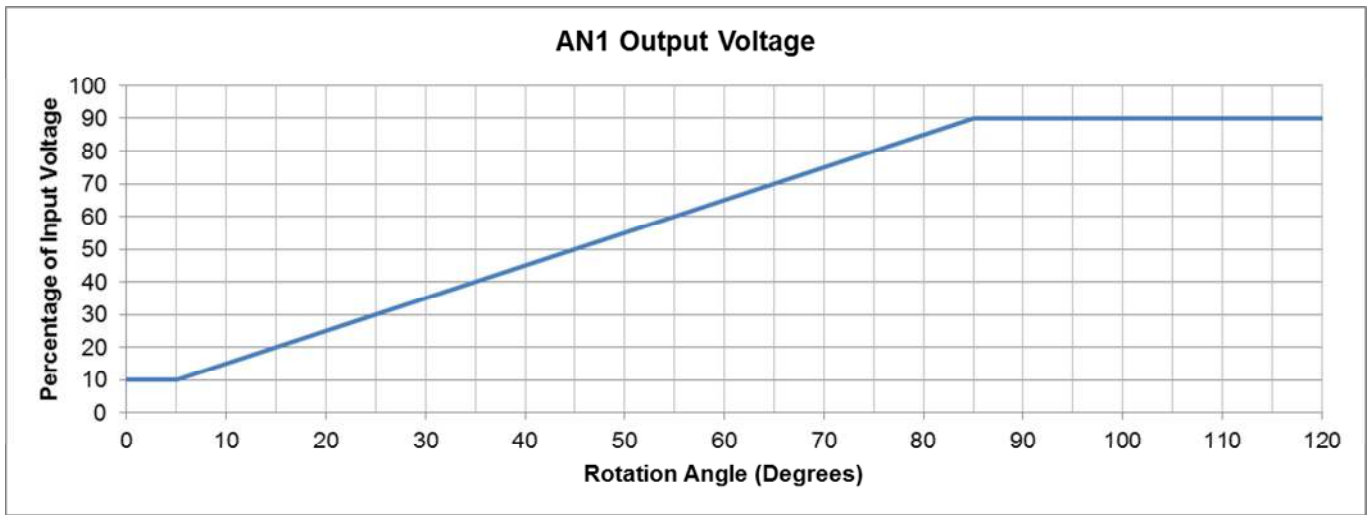

Dimensions mm (inches)

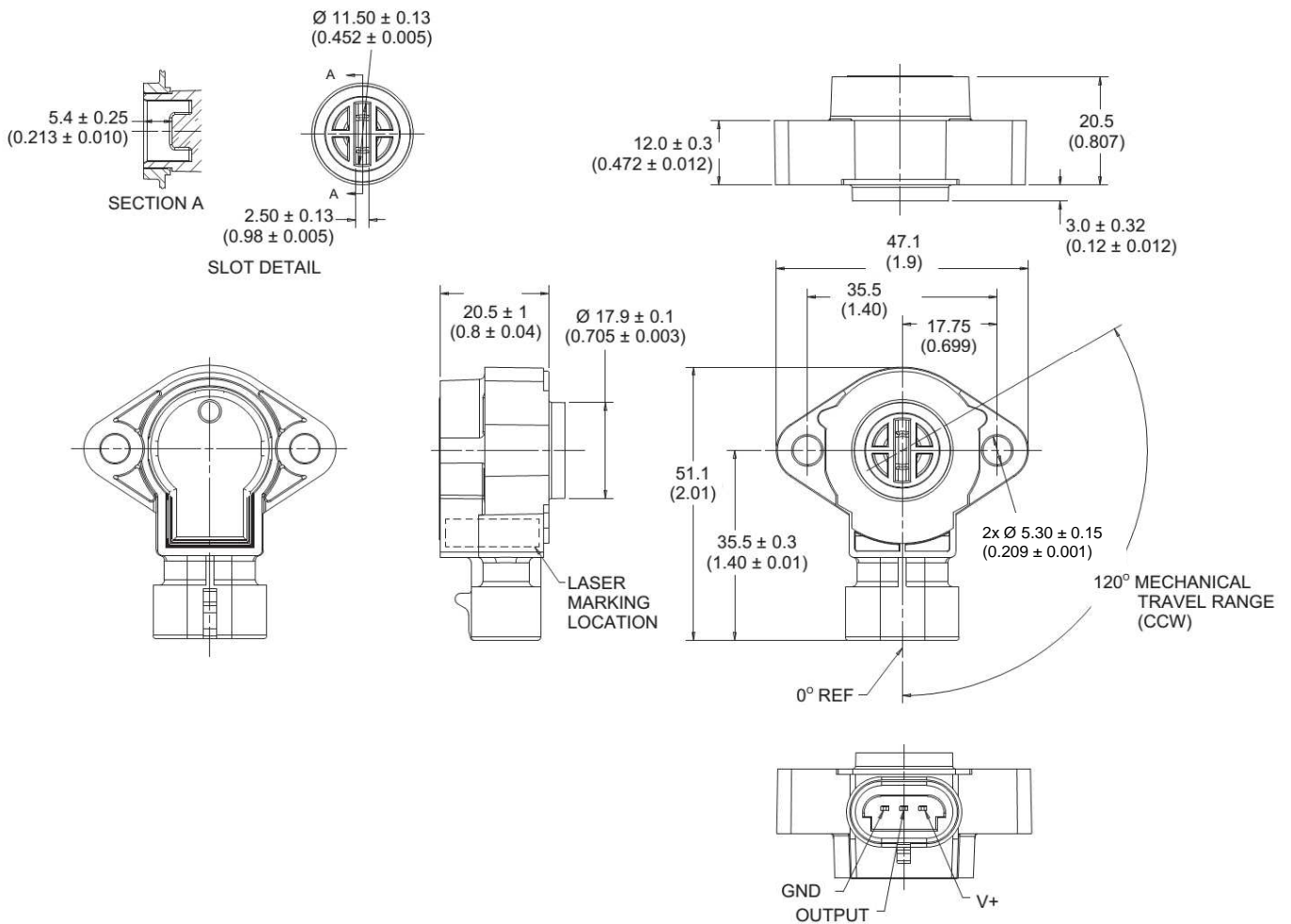

www.switches-sensors.zf.com ZF Electronics Systems Pleasant Prairie, LLC ("ZF") acquired the rights to the CHERRY branded switches and sensors in 2008. Although ZF divested its interest in the CHERRY name in 2015, the switches and sensors remain unchanged and are now sold under the ZF brand.

