

PRODUCT NUMBER
SEE TABLE

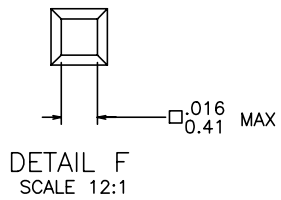
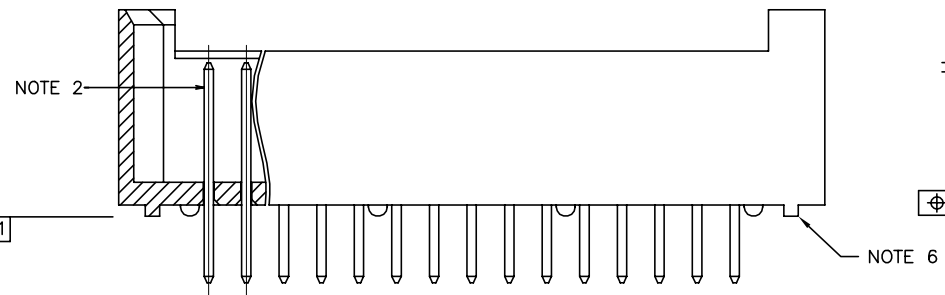
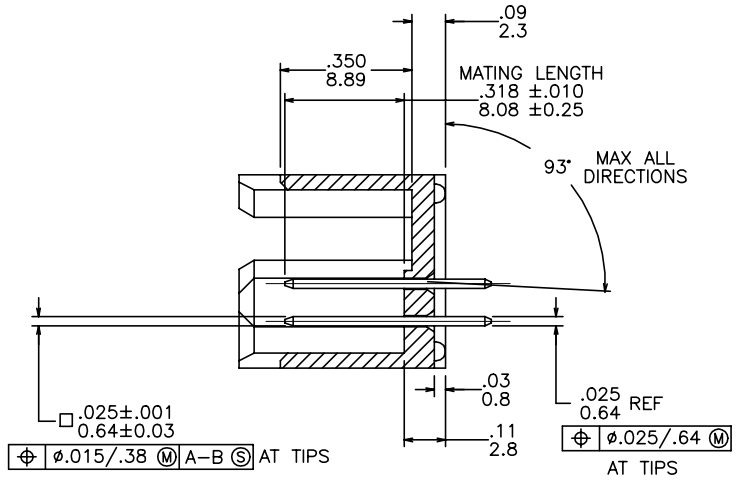
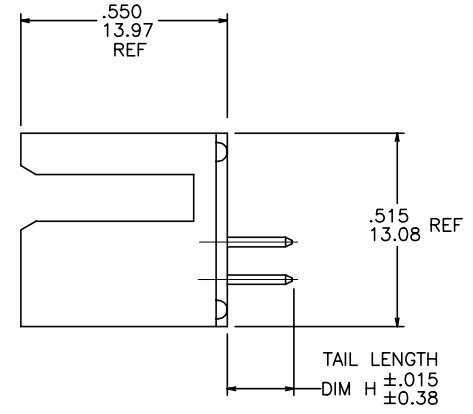
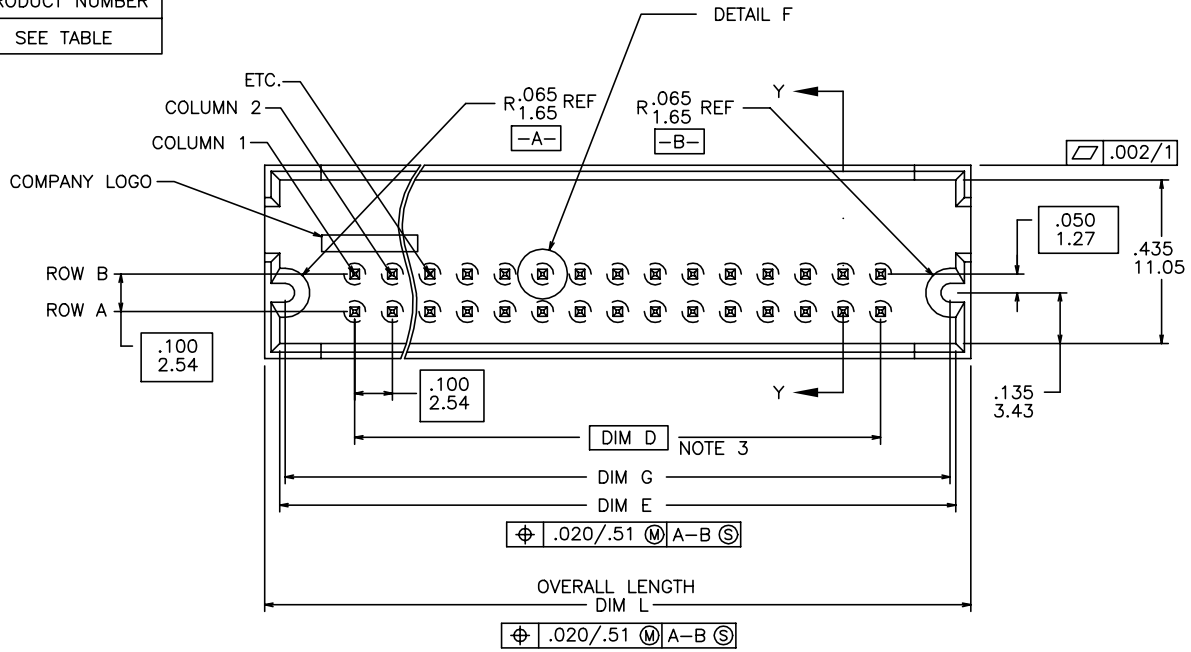

mat'l. code		surface		tolerance		projection		product family	
NOTES 1 & 5		ISO 1302 ✓		ISO 406 ISO 1101				HEADERS	
ltr	ecn no	dr	date	tolerances unless otherwise specified				title	
AD	BLX-14106	DCS	2013-02-06	angles	linear			VERTICAL 2-ROW GUIDE PIN (SLOTTED) HEADER-SOLDER TAILS	
X	V81283	EPK	10/14/98	0°±2'		scale 2:1		dwg no	
Y	V03-0342	GJP	3/21/03	dr	S. ROYER			sheet 1 of 3 size	
AA	M05-0089	MHT	5/16/05	engr	A. MCNEE	3/28/90		67273	
AB	M07-0116	AGS	2/19/07	chr	A. MCNEE	3/28/90		A3	
AC	M09-0059	MHT	4/16/09	appd	A. MCNEE	3/28/90		type Product Customer Drawing	
sheet	revision	AD	AD	AD					
index	sheet	1	2	3					

FCI
FCIconnect.com
Copyright FCI

PRODUCT NUMBER NOTE 4 & 7	SIZE NOTE 4	TAIL LENGTH DIM H	DIM D	DIM G	DIM E	OVERALL LENGTH DIM L	PLATING NOTE 10
67273-XXX	2 x XXX	.177/4.50	NOTE 3	.37/.94+DIM D	.40/10.2+DIM D	.48/12.2+DIM D	30u"/.76u Au OVER 50u"/1.27u Ni
67274-XXX		.177/4.50					15u"/.38u Au OVER 50u"/1.27u Ni
67275-XXX		.177/4.50					GOLD FLASH OVER 50u"/1.27u Ni
67276-XXX		.177/4.50					120u"/3.05u Sn OVER 50u"/1.27u Ni
68513-XXX		.122/3.10					30u"/.76u Au OVER 50u"/1.27u Ni
68581-XXX		.177/4.50					30u"/.76u GXT™ OVER 50u"/1.27u Ni
68839-XXX		.177/4.50					15u"/.38u GXT™ OVER 50u"/1.27u Ni
69291-XXX		.177/4.50					DUPLEX 15u"/.38u Au & 100u"/2.54u Sn OVER 50u"/1.27u Ni
69292-XXX		.177/4.50					DUPLEX 30u"/.76u Au & 100u"/2.54u Sn OVER 50u"/1.27u Ni
69695-XXX		.177/4.50					50u"/1.27u Au OVER 50u"/1.27u Ni
78580-XXX		.122/3.10					30u"/.76u GXT™ OVER 50u"/1.27u Ni
78942-XXX		.122/3.10					120u"/3.05u Sn OVER 50u"/1.27u Ni
78943-XXX		.122/3.10					15u"/.38u GXT™ OVER 50u"/1.27u Ni
78944-XXX		.122/3.10					15u"/.38u Au OVER 50u"/1.27u Ni
90350-XXX		.122/3.10					DUPLEX 30u"/.76u Au & 100u"/2.54u Sn OVER 50u"/1.27u Ni
95737-XXX	2 x XXX	.100/2.54	NOTE 3	.37/.94+DIM D	.40/10.2+DIM D	.48/12.2+DIM D	30u"/.76u GXT™ OVER 50u"/1.27u Ni

NOTES :

- ① MOLDING MATERIAL : HI-TEMP RESIN
PER UL 94 V-0 COLOR : NATURAL
- ② PIN RETENTION TO BE 3 LBS/1.36 KG
MIN PER PIN IN EITHER DIRECTION.
- ③ DIM D =
(NO. OF COLUMNS-1) TIMES .100(ENGLISH)
(NO. OF COLUMNS-1) TIMES 2.54(METRIC)
- ④ -XXX REPRESENTS NO. OF COLUMNS
(i.e. 2 x 5 PART IS -005)
-001 THRU -004 ARE NOT AVAILABLE,
-005 THRU -050 ARE AVAILABLE.
- ⑤ TERMINAL MATERIAL : 3/4/HARD PHOS BRONZE ALLOY
UNS C51000
- ⑥ FLATNESS IS MEASURED FROM THE BOTTOM
OF THE END STANDOFFS.
- ⑦ ADD "LF" SUFFIX AT THE END OF PART NUMBER FOR LEAD FREE OPTION.
8. THE HOUSING WILL WITHSTAND EXPOSURE TO 260°C PEAK TEMPERATURE
FOR 15 SECONDS IN A WAVE SOLDER APPLICATION WITH A 1.5mm
MINIMUM THICK CIRCUIT BOARD. SEE APPLICATION NOTES/PROCEDURES
IF THEY ARE AVAILABLE.
- ⑨ THESE PRODUCT MEETS EUROPEAN UNION DIRECTIVES AND OTHER
COUNTRY REGULATION AS DESCRIBED IN GS-22-008.
- ⑩ PLATING OPTIONS:
MAY BE EITHER GOLD OR GXT PLATED AT MANUFACTURER'S OPTION.
11. FOR 67273 SERIES PLATING OPTIONS:
-XXX=0XX,MAY BE EITHER GOLD OR GXT PLATED AT MANUFACTURER'S OPTION.
-XXX=GXX,GOLD PLATING ONLY

mat'l. code		surface		tolerance		projection		product family	
NOTES 1 & 5		ISO 1302 ✓		ISO 406 ISO 1101				HEADERS	
ltr	ecn	no	dr	date		tolerances unless otherwise specified		title	
AD						angles linear .XX±.01/.XX±0.3 .XXX±.005/.XX±0.13 .XXXX±.0020/.XXX±0.05		INCH/MM VERTICAL 2-ROW GUIDE PIN (SLOTTED) HEADER-SOLDER TAILS	
						dr S. ROYER 3/28/90 engr A. MCNEE 3/28/90 chr A. MCNEE 3/28/90 appd A. MCNEE 3/28/90		scale 2:1 FCJ sheet 2 of 3 size 67273 A3	
sheet index		revision sheet						type Product Customer Drawing	

PRODUCT NUMBER NOTE 4 & 7	SIZE NOTE 4	TAIL LENGTH DIM H	DIM D	DIM G	DIM E	OVERALL LENGTH DIM L	PLATING
67273-XXXLF	2 x XXX	.177/4.50	NOTE 3	.37/.94+DIM D	.40/10.2+DIM D	.48/12.2+DIM D	30u"/.76u Au OVER 50u"/1.27u Ni
67274-XXXLF		.177/4.50					15u"/.38u Au OVER 50u"/1.27u Ni
67275-XXXLF		.177/4.50					GOLD FLASH OVER 50u"/1.27u Ni
67276-XXXLF		.177/4.50					100u"/2.54u PURE Sn OVER 50u"/1.27u Ni
68513-XXXLF		.122/3.10					30u"/.76u Au OVER 50u"/1.27u Ni
68581-XXXLF		.177/4.50					30u"/.76u GXT™ OVER 50u"/1.27u Ni
68839-XXXLF		.177/4.50					15u"/.38u GXT™ OVER 50u"/1.27u Ni
69291-XXXLF		.177/4.50					DUPLEX 15u"/.38u Au & 100u"/2.54u PURE Sn OVER 50u"/1.27u Ni
69292-XXXLF		.177/4.50					DUPLEX 30u"/.76u Au & 100u"/2.54u PURE Sn OVER 50u"/1.27u Ni
69695-XXXLF		.177/4.50					50u"/1.27u Au OVER 50u"/1.27u Ni
78580-XXXLF		.122/3.10					30u"/.76u GXT™ OVER 50u"/1.27u Ni
78942-XXXLF		.122/3.10					100u"/2.54u PURE Sn OVER 50u"/1.27u Ni
78943-XXXLF		.122/3.10					15u"/.38u GXT™ OVER 50u"/1.27u Ni
78944-XXXLF		.122/3.10					15u"/.38u Au OVER 50u"/1.27u Ni
90350-XXXLF		.122/3.10					DUPLEX 30u"/.76u Au & 100u"/2.54u PURE Sn OVER 50u"/1.27u Ni
95737-XXXLF	2 x XXX	.100/2.54	NOTE 3	.37/.94+DIM D	.40/10.2+DIM D	.48/12.2+DIM D	30u"/.76u GXT™ OVER 50u"/1.27u Ni

SEE NOTE 11

SEE NOTE 10

mat'l. code NOTES 1 & 5		surface ISO 1302 ✓	tolerance ISO 406 ISO 1101	projection 	product family HEADERS
ltr	ecn no	dr	date	tolerances unless otherwise specified	title
AD				angles linear XXX±.01/XXX±.03 XXX±.005/XXX±0.13 XXXX±.0020/XXX±0.05	VERTICAL 2-ROW GUIDE PIN (SLOTTED) HEADER-SOLDER TAILS
				0°±2'	INCH/MM
				dr S. ROYER 3/28/90	scale 2:1
				enr A. MCNEE 3/28/90	FCJ
				chr A. MCNEE 3/28/90	dwg no 67273 sheet 3 of 3 size A3
				appd A. MCNEE 3/28/90	type Product Customer Drawing
sheet index	revision sheet				