

## 54191/DM54191/DM74191 Synchronous Up/Down 4-Bit Binary Counter with Mode Control

### General Description

This circuit is a synchronous, reversible, up/down counter. The 191 is a 4-bit binary counter. Synchronous operation is provided by having all flip-flops clocked simultaneously so that the outputs change simultaneously when so instructed by the steering logic. This mode of operation eliminates the output counting spikes normally associated with asynchronous (ripple clock) counters.

The outputs of the four master-slave flip-flops are triggered on a low-to-high level transition of the clock input, if the enable input is low. A high at the enable input inhibits counting. Level changes at either the enable input or the down/up input should be made only when the clock input is high. The direction of the count is determined by the level of the down/up input. When low, the counter counts up and when high, it counts down.

This counter is fully programmable; that is, the outputs may be preset to either level by placing a low on the load input and entering the desired data at the data inputs. The output will change independent of the level of the clock input. This feature allows the counters to be used as modulo-N dividers by simply modifying the count length with the preset inputs.

The clock, down/up, and load inputs are buffered to lower the drive requirement; which significantly reduces the number of clock drivers, etc., required for long parallel words.

Two outputs have been made available to perform the cascading function: ripple clock and maximum/minimum count. The latter output produces a high-level output pulse with a duration approximately equal to one complete cycle of the clock when the counter overflows or underflows. The ripple clock output produces a low-level output pulse equal in width to the low-level portion of the clock input when an overflow or underflow condition exists. The counters can be easily cascaded by feeding the ripple clock output to the enable input of the succeeding counter if parallel clocking is used, or to the clock input if parallel enabling is used. The maximum/minimum count output can be used to accomplish look-ahead for high-speed operation.

### Features

- Single down/up count control line
- Count enable control input
- Ripple clock output for cascading
- Asynchronously presettable with load control
- Parallel outputs
- Cascadable for n-bit applications
- Alternate Military/Aerospace device (54191) is available. Contact a National Semiconductor Sales Office/Distributor for specifications.

### Connection Diagram

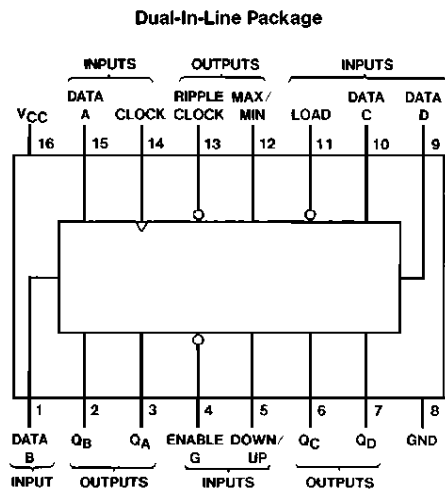

TL/F/6562-1

Order Number 54191DMQB, 54191FMQB,  
DM54191J, DM54191W or DM74191N  
See NS Package Number J16A, N16E or W16A

54191/DM54191/DM74191 Synchronous Up/Down 4-Bit Binary Counter with Mode Control

## Absolute Maximum Ratings (Note)

If Military/Aerospace specified devices are required, please contact the National Semiconductor Sales Office/Distributors for availability and specifications.

Supply Voltage	7V
Input Voltage	5.5V
Operating Free Air Temperature Range	
DM54 and 54	−55°C to +125°C
DM74	0°C to +70°C
Storage Temperature Range	−65°C to +150°C

Note: The "Absolute Maximum Ratings" are those values beyond which the safety of the device cannot be guaranteed. The device should not be operated at these limits. The parametric values defined in the "Electrical Characteristics" table are not guaranteed at the absolute maximum ratings. The "Recommended Operating Conditions" table will define the conditions for actual device operation.

## Recommended Operating Conditions

Symbol	Parameter	DM54191			DM74191			Units
		Min	Nom	Max	Min	Nom	Max	
V <sub>CC</sub>	Supply Voltage	4.5	5	5.5	4.75	5	5.25	V
V <sub>IH</sub>	High Level Input Voltage	2			2			V
V <sub>IL</sub>	Low Level Input Voltage			0.8			0.8	V
I <sub>OH</sub>	High Level Output Current			−0.8			−0.8	mA
I <sub>OL</sub>	Low Level Output Current			16			16	mA
f <sub>CLK</sub>	Clock Frequency (Note 4)	0		20	0		20	MHz
t <sub>w</sub>	Pulse Width (Note 4)	Clock	25		25			ns
		Load	35		35			
t <sub>SU</sub>	Data Setup Time (Note 4)	28			28			ns
t <sub>H</sub>	Hold Time (Note 4)	0			0			ns
t <sub>REL</sub>	Load Release Time (Note 4)	30			30			ns
T <sub>A</sub>	Free Air Operating Temperature	−55		125	0		70	°C

## Electrical Characteristics over recommended operating free air temperature range (unless otherwise noted)

Symbol	Parameter	Conditions	Min	Typ (Note 1)	Max	Units
V <sub>I</sub>	Input Clamp Voltage	V <sub>CC</sub> = Min, I <sub>I</sub> = −12 mA			−1.5	V
V <sub>OH</sub>	High Level Output Voltage	V <sub>CC</sub> = Min, I <sub>OH</sub> = Max V <sub>IL</sub> = Max, V <sub>IH</sub> = Min	2.4	3.4		V
V <sub>OL</sub>	Low Level Output Voltage	V <sub>CC</sub> = Min, I <sub>OL</sub> = Max V <sub>IH</sub> = Min, V <sub>IL</sub> = Max		0.2	0.4	V
I <sub>I</sub>	Input Current @ Max Input Voltage	V <sub>CC</sub> = Max, V <sub>I</sub> = 5.5V			1	mA
I <sub>IH</sub>	High Level Input Current	V <sub>CC</sub> = Max V <sub>I</sub> = 2.4V	Enable		120	μA
			Others		40	
I <sub>IL</sub>	Low Level Input Current	V <sub>CC</sub> = Max V <sub>I</sub> = 0.4V	Enable		−4.8	mA
			Others		−1.6	
I <sub>OS</sub>	Short Circuit Output Current	V <sub>CC</sub> = Max (Note 2)	DM54	−20	−65	mA
			DM74	−18	−65	
I <sub>CC</sub>	Supply Current	V <sub>CC</sub> = Max (Note 3)	DM54	65	99	mA
			DM74	65	105	

Note 1: All typicals are at V<sub>CC</sub> = 5V, T<sub>A</sub> = 25°C.

Note 2: Not more than one output should be shorted at a time.

Note 3: I<sub>CC</sub> is measured with all inputs grounded and all outputs open.

Note 4: T<sub>A</sub> = 25°C and V<sub>CC</sub> = 5V.

**Switching Characteristics** at  $V_{CC} = 5V$  and  $T_A = 25^\circ C$  (See Section 1 for Test Waveforms and Output Load)

Symbol	Parameter	From (Input) To (Output)	$R_L = 400\Omega, C_L = 15\text{ pF}$		Units
			Min	Max	
$f_{MAX}$	Maximum Clock Frequency		20		MHz
$t_{PLH}$	Propagation Delay Time Low to High Level Output	Load to Any Q		33	ns
$t_{PHL}$	Propagation Delay Time High to Low Level Output	Load to Any Q		70	ns
$t_{PLH}$	Propagation Delay Time Low to High Level Output	Data to Any Q		22	ns
$t_{PHL}$	Propagation Delay Time High to Low Level Output	Data to Any Q		70	ns
$t_{PLH}$	Propagation Delay Time Low to High Level Output	Clock to Ripple Carry		20	ns
$t_{PHL}$	Propagation Delay Time High to Low Level Output	Clock to Ripple Carry		24	ns
$t_{PLH}$	Propagation Delay Time Low to High Level Output	Clock to Any Q		24	ns
$t_{PHL}$	Propagation Delay Time High to Low Level Output	Clock to Any Q		36	ns
$t_{PLH}$	Propagation Delay Time Low to High Level Output	Clock to Max/Min		42	ns
$t_{PHL}$	Propagation Delay Time High to Low Level Output	Clock to Max/Min		52	ns
$t_{PLH}$	Propagation Delay Time Low to High Level Output	Down/Up to Ripple Carry		45	ns
$t_{PHL}$	Propagation Delay Time High to Low Level Output	Down/Up to Ripple Carry		45	ns
$t_{PLH}$	Propagation Delay Time Low to High Level Output	Down/Up to Max/Min		33	ns
$t_{PHL}$	Propagation Delay Time High to Low Level Output	Down/Up to Max/Min		33	ns
$t_{PLH}$	Propagation Delay Time Low to High Level Output	Enable G to Ripple Carry		24	ns
$t_{PHL}$	Propagation Delay Time High to Low Level Output	Enable G to Ripple Carry		24	ns

# Logic Diagram

## 191 Binary Counter

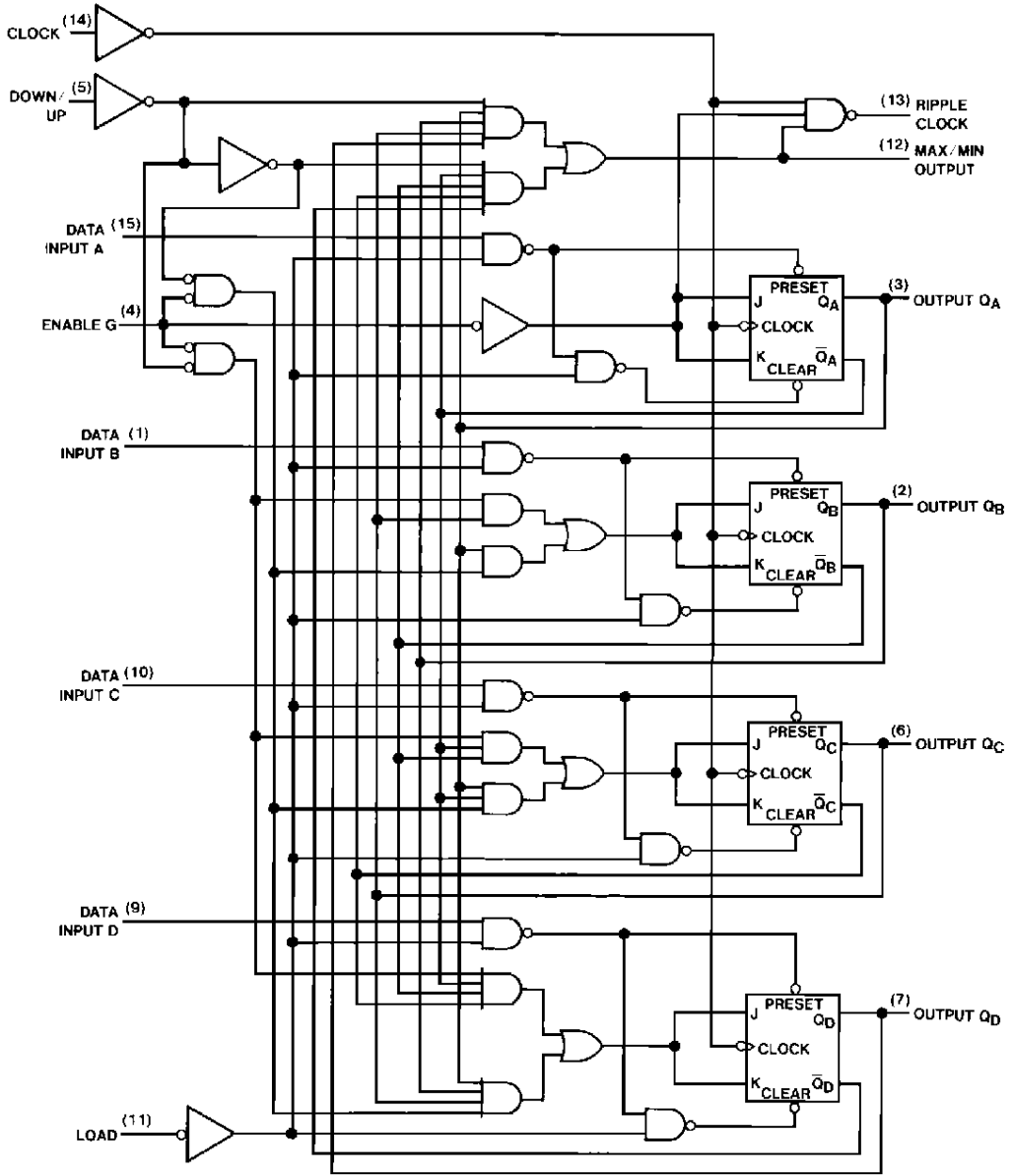

TL/F/6562-2

Pin (16) = V<sub>CC</sub>, Pin (8) = GND

# Timing Diagrams

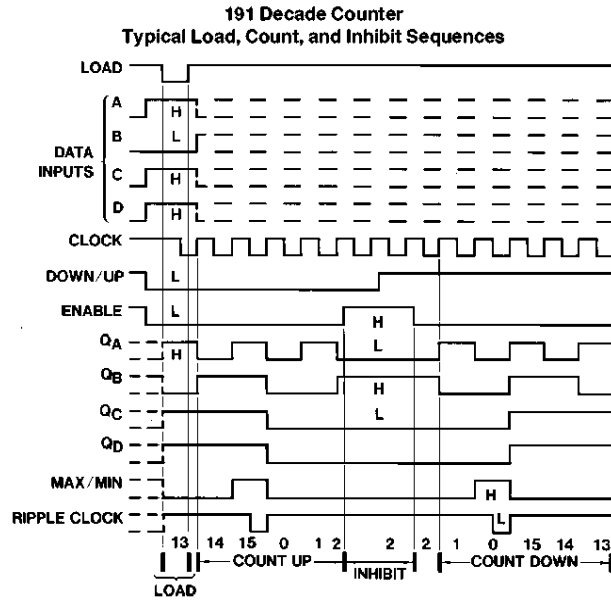

TL/F/6562-3

# Physical Dimensions inches (millimeters)

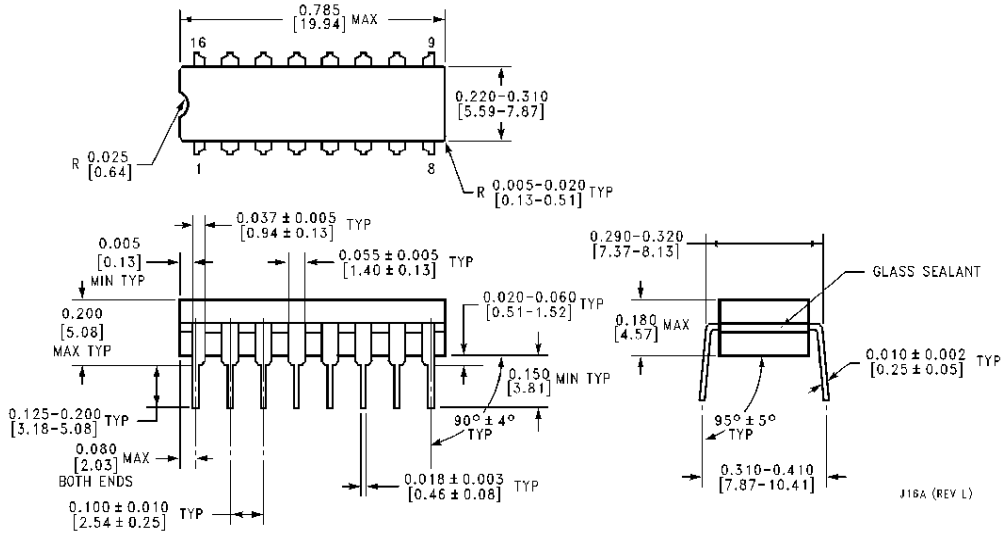

J16A (REV L)

**16-Lead Ceramic Dual-In-Line Package (J)**  
Order Number 54191DMQB or DM54191J  
NS Package Number J16A

**Physical Dimensions** inches (millimeters) (Continued)

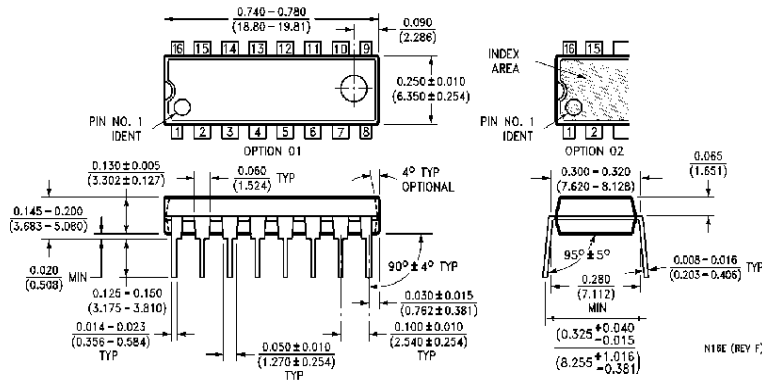

**16-Lead Molded Dual-In-Line Package (N)**  
**Order Number DM74191N**  
**NS Package Number N16E**

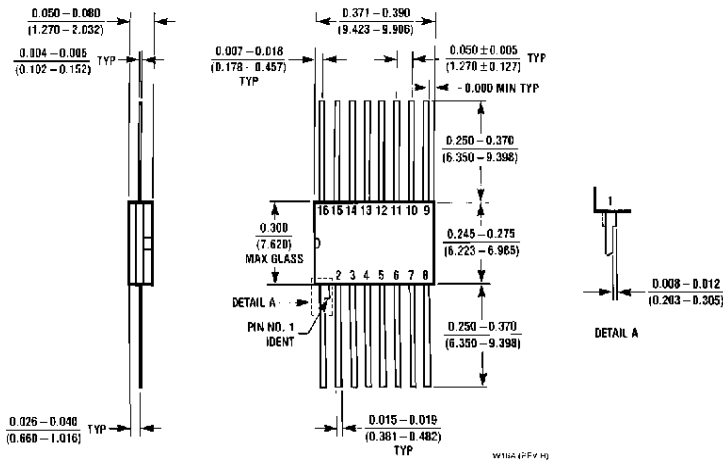

**16-Lead Ceramic Flat Package (W)**  
**Order Number 54191FMQB or DM54191W**  
**NS Package Number W16A**

**LIFE SUPPORT POLICY**

NATIONAL'S PRODUCTS ARE NOT AUTHORIZED FOR USE AS CRITICAL COMPONENTS IN LIFE SUPPORT DEVICES OR SYSTEMS WITHOUT THE EXPRESS WRITTEN APPROVAL OF THE PRESIDENT OF NATIONAL SEMICONDUCTOR CORPORATION. As used herein:

1. Life support devices or systems are devices or systems which, (a) are intended for surgical implant into the body, or (b) support or sustain life, and whose failure to perform, when properly used in accordance with instructions for use provided in the labeling, can be reasonably expected to result in a significant injury to the user.
2. A critical component is any component of a life support device or system whose failure to perform can be reasonably expected to cause the failure of the life support device or system, or to affect its safety or effectiveness.

 <p><b>National Semiconductor Corporation</b>          1111 West Bardin Road          Arlington, TX 76017          Tel: 1(800) 272-9959          Fax: 1(800) 737-7016</p>	<p><b>National Semiconductor Europe</b>          Fax: (+49) 0-180-530 85 86          Email: cnjwge@tevm2.nsc.com          Deutsch Tel: (+49) 0-180-530 85 85          English Tel: (+49) 0-180-532 78 32          Français Tel: (+49) 0-180-532 93 58          Italiano Tel: (+49) 0-180-534 16 80</p>	<p><b>National Semiconductor Hong Kong Ltd.</b>          13th Floor, Straight Block,          Ocean Centre, 5 Canton Rd.          Tsimshatsui, Kowloon          Hong Kong          Tel: (852) 2737-1600          Fax: (852) 2736-9960</p>	<p><b>National Semiconductor Japan Ltd.</b>          Tel: 81-043-299-2309          Fax: 81-043-299-2408</p>
--	--	---	---

National does not assume any responsibility for use of any circuitry described, no circuit patent licenses are implied and National reserves the right at any time without notice to change said circuitry and specifications.