

M5X0.8-6H 8mm(2X) DEEP THREADED INSERT

RECOMMENDED TORQUE VALUES:1.9-2.2 N.m

REVISIONS					
REV	ECO	DESCRIPTION	DATE	BY	APPR
A1	--	RELEASE NEW DRAWING	28MAR22	VITO	TOMMY
A2	--	REVISE THE VIEWS	1/MAR/23	VITO	TOMMY

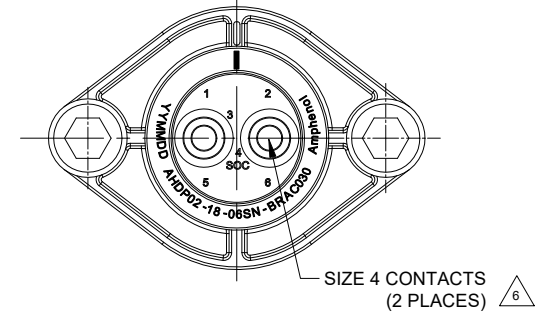

NOTES: UNLESS OTHERWISE SPECIFIED

- MATERIAL:  
HOUSING: THERMOPLASTIC; BLACK  
SEAL: SILICONE RUBBER  
THREADED INSERT: STAINLESS STEEL
- MODIFICATIONS: BACKSHELL RING ADAPTER (BRA);  
STANDARD DIA. WIRE SEAL.  
SEALED PANEL MOUNT;
- SPECIFICATIONS:  
3.1 OPERATING TEMPERATURE: -55°C TO +125°C.  
3.2 DIELECTRIC WITHSTANDING VOLTAGE: LESS THAN 2 MILLIAMPS CURRENT LEAKAGE @ 1500 VOLTS AC.  
3.3 INSULATION RESISTANCE: 1000 MEGOHM MIN @ 25°C.  
3.4 MOISTURE RESISTANCE:  
IP68(IM OF WATER FOR A PERIOD OF 24 HOURS,MATED CONDITION);  
IP69K (MATED CONDITION)  
3.5 MATING CYCLE DURABILITY: 100 CYCLES  
3.6 RoHS COMPLIANT
- MATING PART: AHDP06-18-06P\* (\* = SEAL TYPE) (C030 OPTION)
- ALL DIMENSIONS ARE FOR REFERENCE USE ONLY.

6 CONTACT SIZE AND WIRE RANGE:

CONTACT SIZE	MIN. INSUL O.D.	MAX. INSUL O.D.	TYPICAL WIRE RANGE	CURRENT RATING
4	6.63 mm (.261in)	7.41mm (.292 in)	6 AWG (16-13mm <sup>2</sup> )	100 AMPS

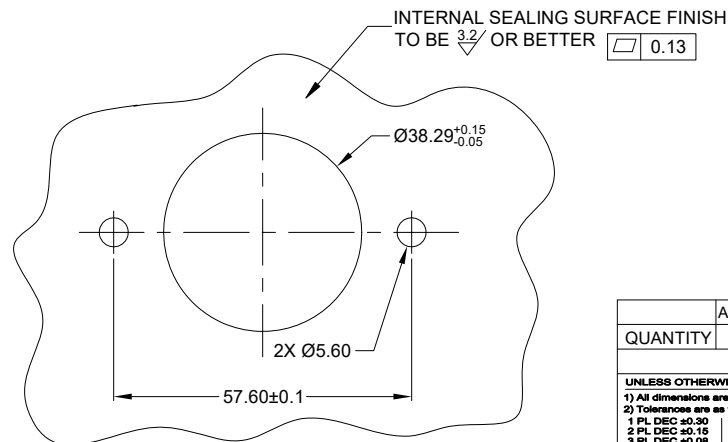

RECOMMENDED PANEL MOUNTING HOLE

RECOMMENDED PANEL THICKNESS:1.6 TO 4.7MM

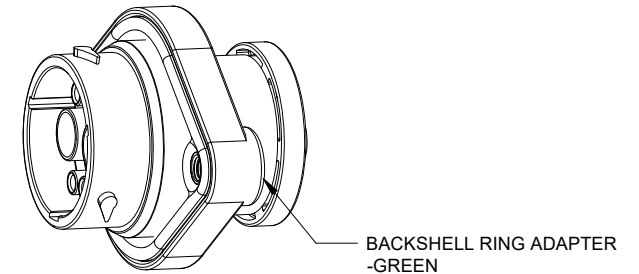

BACKSHELL RING ADAPTER -GREEN

QUANTITY	AHDP02-18-06SN-BRAC030	PART NUMBER	DESCRIPTION	ITEM
<b>MATERIALS LIST</b>				
<b>UNLESS OTHERWISE SPECIFIED</b> 1) All dimensions are in metric(mm). 2) Tolerances are as follows: 1 PL DEC ±0.30 Fractions ±1/64 2 PL DEC ±0.15 Angles ±1° 3 PL DEC ±0.08 3) Note reference =		<b>SIGNATURES DATE</b> DRAWN: VITOLI 1/MAR/23 CHECKED: SULLENZHANG 02/MAR/22 ENGINEER: APPROVAL: TOMMY XIE 03/MAR/22		
<b>MATERIAL SPECIFICATIONS:</b> WEIGHT: 52.7g		<b>CUSTOMER:</b> THIS DRAWING IS SUPPLIED FOR INFORMATION ONLY. DESIGN FEATURES, SPECIFICATIONS AND PERFORMANCE DATA SHOWN HEREON ARE THE PROPERTY OF THE AMPHENOL CORPORATION. NO RIGHTS OF REPRODUCTION ARE IMPLIED. ALL DIMENSIONS ARE SUBJECT TO NORMAL MANUFACTURING VARIATIONS.		
<b>PROCESS SPECIFICATIONS:</b>		<b>SIZE TYPE DWG NO. REVISION</b> <b>B C- AHDP02-18-06SN-BRAC030 A2</b>		
<b>NEXT ASSY:</b>		SCALE: NONE DURAMATE SHEET 1 OF 1		

TITLE: 2POS RECEPT SOCKET PANELMATE AHDP SIZE 18, NORMAL SEAL, BRA, C030  
 DWG NO: AHDP02-18-06SN-BRAC030  
 REV: A2  
 SH: 1  
 OF: 1