

Spezifikation für Freigabe / specification for release

Kunde / customer :
 Artikelnummer / part number : **749050010U**
 Bezeichnung : **LAN-Übertrager WE-LAN 10G**
 description : **LAN-Transformer WE-LAN 10G**



DATUM / DATE : 2017-10-13

A Mechanische Abmessungen / dimensions :

10G BaseT

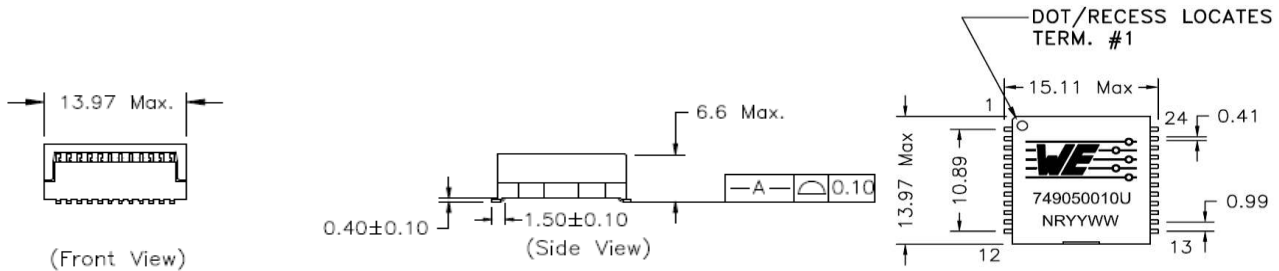

B Elektrische Eigenschaften / electrical properties :

Eigenschaften / properties	Testbedingungen / test conditions		Wert / value	Einheit / unit	tol.
Induktivität / Inductance	100kHz / 100mV @ 0mA DC-Bias	OCL	200	μH	min.
Übersetzungsverhältnis / Turns ratio	100kHz / 100mV	TR	1 : 1		±2%
Insertion Loss	100k-10MHz	IL	-1,0	dB	min.
	100k-650MHz		-3,0		
Return Loss	1-40MHz	RL	-18,0	dB	min.
	40-400MHz		-10,0		
	400-500MHz		-8,0		
	500-600MHz		-5,0		
Common Mode Rejection	1-250MHz	CMR	-30	dB	min.
	250-500MHz		-22		
Crosstalk	1-100MHz	CT	-40	dB	min.
	100-500MHz		-30		

C Lötpad / soldering spec. :

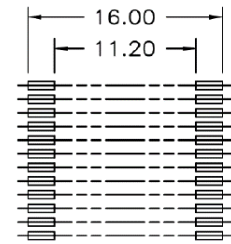

(SUGGESTED PCB PAD LAYOUT)

D Prüfgeräte / test equipment :

HP4395A

E Testbedingungen / test conditions :

Luftfeuchtigkeit / Humidity: 33%
 Umgebungstemperatur / Temperature: +25°C

F Werkstoffe & Zulassungen / material & approvals :

Basismaterial / Base material: Ferrit / Ferrite
 Draht / Wire: 0UEW/Y 180
 Kontaktmaterial / Contact plating: Cu-Ni-Sn
 Gehäuse / Case: UL94V-0
 Verguss / Potting: UL94V-0

G Eigenschaften / general specifications :

Betriebstemp. / Operating temperature: 0°C - +70°C
 Hochspannungsprüfung / Hipot test: 1500Vrms 1min.

Freigabe erteilt / general release:	Kunde / customer	JaB	Version 08	2017-10-13
		JaB	Version 07	2016-08-09
Datum / date	Unterschrift / signature	JaB	Version 06	2016-07-26
		JaB	Version 05	2015-02-13
Geprüft / checked	Kontrolliert / approved	MLe	Version 04	2013-12-16
		MLe	Version 03	2013-08-27
		MLe	Version 02	2013-02-25
		MLe	Version 01	2012-05-07
		Name	Änderung / modification	Datum / date

Würth Elektronik eiSos GmbH & Co.KG

D-74638 Waldenburg · Max-Eyth-Straße 1 - 3 · Germany · Telefon (+49) (0) 7942 - 945 - 0 · Telefax (+49) (0) 7942 - 945 - 400
<http://www.we-online.com>

Spezifikation für Freigabe / specification for release

Kunde / customer :
 Artikelnummer / part number : **749050010U**
 Bezeichnung : **LAN-Übertrager WE-LAN 10G**
 description : **LAN-Transformer WE-LAN 10G**



DATUM / DATE : 2017-10-13

H Schaltbild / Schematics :

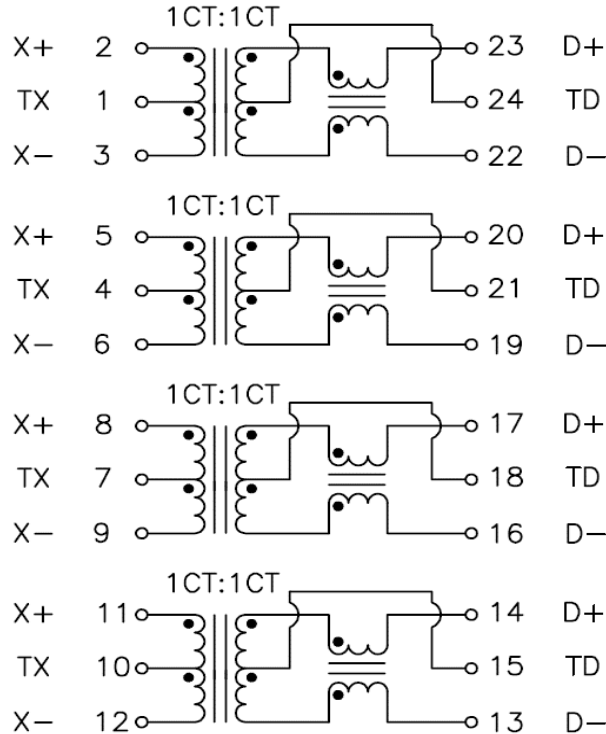

Freigabe erteilt / general release:	Kunde / customer	JaB	Version 08	2017-10-13
		JaB	Version 07	2016-08-09
		JaB	Version 06	2016-07-26
		JaB	Version 05	2015-02-13
Datum / date	Unterschrift / signature	MLe	Version 04	2013-12-16
	Würth Elektronik	MLe	Version 03	2013-08-27
		MLe	Version 02	2013-02-25
		MLe	Version 01	2012-05-07
Geprüft / checked	Kontrolliert / approved	Name	Änderung / modification	Datum / date

Würth Elektronik eiSos GmbH & Co.KG

D-74638 Waldenburg · Max-Eyth-Straße 1 - 3 · Germany · Telefon (+49) (0) 7942 - 945 - 0 · Telefax (+49) (0) 7942 - 945 - 400
<http://www.we-online.com>

Spezifikation für Freigabe / specification for release

Kunde / customer :
 Artikelnummer / part number : **749050010U**
 Bezeichnung : **LAN-Übertrager WE-LAN 10G**
 description : **LAN-Transformer WE-LAN 10G**



DATUM / DATE : 2017-10-13

I Rollenspezifikation / tape and reel specification :

Gurtspezifikation / Tape specification:

PACKAGING(Tape & Reel)

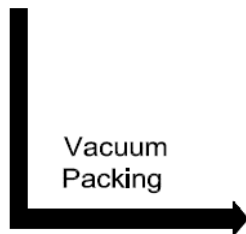
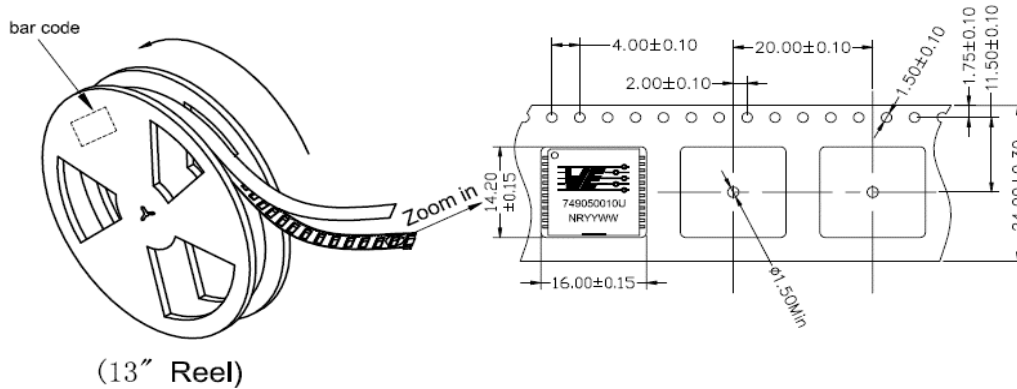

Outside Carton

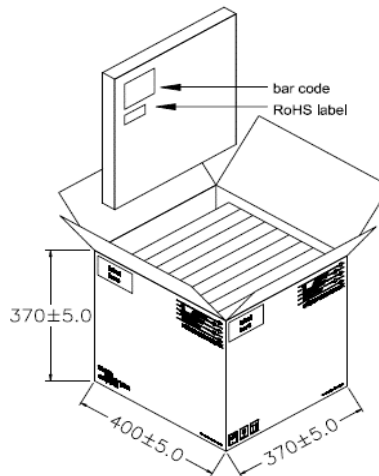

PACKING QUANTITY:

450pcs Finished Goods / Reel

10 Reels (4500pcs Finished Goods) / Carton

Freigabe erteilt / general release:	Kunde / customer	JaB	Version 08	2017-10-13	
		JaB	Version 07	2016-08-09	
		JaB	Version 06	2016-07-26	
		JaB	Version 05	2015-02-13	
	Datum / date	Unterschrift / signature	MLe	Version 04	2013-12-16
		Würth Elektronik	MLe	Version 03	2013-08-27
			MLe	Version 02	2013-02-25
			MLe	Version 01	2012-05-07
Geprüft / checked	Kontrolliert / approved	Name	Änderung / modification	Datum / date	

This electronic component has been designed and developed for usage in general electronic equipment. Before incorporating this component into any equipment where higher safety and reliability is especially required or if there is the possibility of direct damage or injury to human body, for example in the range of aerospace, aviation, nuclear control, submarine, transportation, (automotive control, train control, ship control), transportation signal, disaster prevention, medical, public information network etc, Würth Elektronik eiSos GmbH must be informed before the design-in stage. In addition, sufficient reliability evaluation checks for safety must be performed on every electronic component which is used in electrical circuits that require high safety and reliability functions or performance.

Würth Elektronik eiSos GmbH & Co.KG

D-74638 Waldenburg · Max-Eyth-Straße 1 - 3 · Germany · Telefon (+49) (0) 7942 - 945 - 0 · Telefax (+49) (0) 7942 - 945 - 400
<http://www.we-online.com>