

Customer Information Sheet

DRAWING No.: P70-5100045

IF IN DOUBT - ASK

©

NOT TO SCALE

THIRD ANGLE PROJECTION

ALL DIMENSIONS IN mm

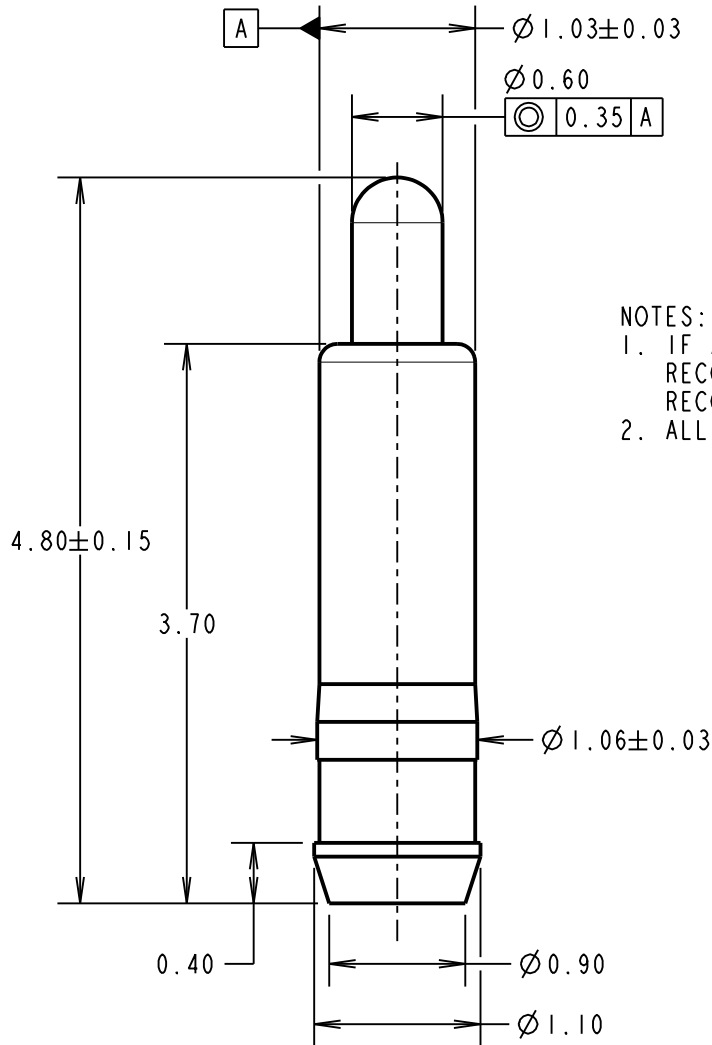

RECOMMENDED PCB PAD LAYOUT

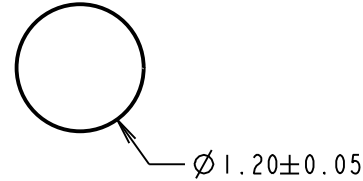

NOTES:

- IF ASSEMBLING PIN INTO MOULDING:
RECOMMENDED HOLE SIZE = $\varnothing 1.00$ MIN.
RECOMMENDED MATERIAL = GLASS FILLED PA46.
- ALL PRODUCTS ARE RoHS COMPLIANT.

SPECIFICATION:

MATERIAL:

BODY & PLUNGER = BRASS
SPRING = STAINLESS STEEL WIRE

PLATING:

BODY = $0.1 \mu\text{m}$ GOLD OVER $1.4 \mu\text{m}$ NICKEL
PLUNGER = $0.4 \mu\text{m}$ GOLD OVER $1.4 \mu\text{m}$ NICKEL

ELECTRICAL:

CONTACT RESISTANCE = $30\text{m}\Omega$ MAX
CURRENT RATING = 2.0A

MECHANICAL:

FORCE AT NORMAL HEIGHT = $0.98\text{N} \pm 0.29\text{N}$
DURABILITY = 10,000 CYCLES

ENVIRONMENTAL:

OPERATING TEMPERATURE = -40°C TO 85°C

PACKING:

BAG

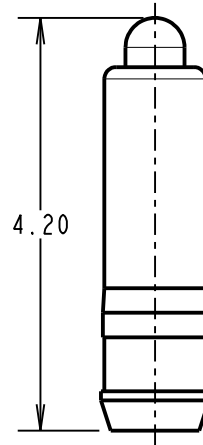

MAXIMUM WORKING HEIGHT

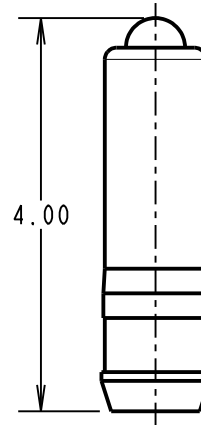

NORMAL WORKING HEIGHT

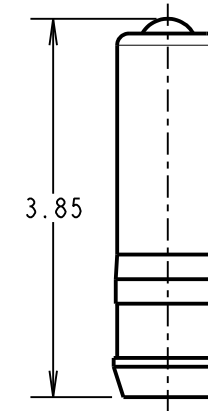

MINIMUM WORKING HEIGHT/MAX ALLOWED TRAVEL

RTP	2	04.06.21	30572
NAME	ISS.	DATE	CN/CO
APPROVED:		R.PORTLOCK	
CHECKED:		M.RUDKIN	
DRAWN:		S.BENNETT	
CUSTOMER REF.:			
ASSEMBLY DRG:			

HARWIN

www.harwin.com
technical@harwin.com

THIS DRAWING AND ANY INFORMATION OR DESCRIPTIVE MATTER SET OUT HEREON ARE CONFIDENTIAL AND COPYRIGHT PROPERTY OF THE HARWIN GROUP AND MUST NOT BE DISCLOSED, LOANED, COPIED OR USED FOR MANUFACTURING, TENDERING OR FOR ANY OTHER PURPOSE WITHOUT THEIR WRITTEN PERMISSION.

TOLERANCES

X. = $\pm 1\text{mm}$
X.X = $\pm 0.50\text{mm}$
X.XX = $\pm 0.20\text{mm}$
X.XXX = $\pm 0.01\text{mm}$

ANGLES = $\pm 5^\circ$

UNLESS STATED

MATERIAL:

SEE ABOVE

FINISH: SEE ABOVE

S/AREA: mm²

TITLE:

SMT SPRING LOADED POGO PIN

DRAWING NUMBER:

P70-5100045

SHT
2 OF 2