

TC1275/TC1276/TC1277

3-Pin Reset Monitors for 3.3V Systems

Features

- Precision V_{CC} Monitor for 3.3V Systems
- 100 ms Minimum RESET, RESET Output Duration
- Output Valid to $V_{CC} = 1.2V$
- V_{CC} Transient Immunity
- Small 3-Pin SOT-23 Package
- No External Components

Applications

- Computers
- Embedded Systems
- Battery Powered Equipment
- Critical μP Power Supply Monitoring

Device Selection Table

Part Number	Order	Package	Temp. Range
TC1275-xENB	Complimentary	3-Pin SOT-23	-40°C to +85°C
TC1276-xENB	Open-Drain	3-Pin SOT-23	-40°C to +85°C
TC1277-xENB	Complimentary	3-Pin SOT-23	-40°C to +85°C

NOTE: "x" denotes a suffix for V_{CC} threshold (see table below).

Suffix	Reset V_{CC} Threshold (V)
5	3.06
10	2.88
20	2.55

Package Type

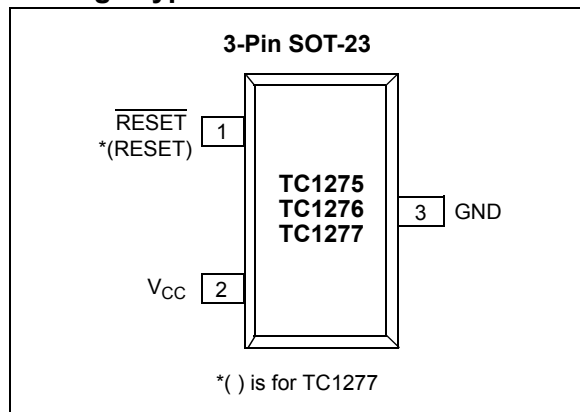

General Description

The TC1275/TC1276/TC1277 are cost-effective system supervisor circuits designed to monitor V_{CC} in digital systems and provide a reset signal to the host processor when necessary. No external components are required.

The reset output is driven active within 20 μs of V_{CC} falling through the reset voltage threshold. RESET is maintained active for a minimum of 100 ms after V_{CC} rises above the reset threshold. The TC1277 has an active-high RESET output while the TC1275 and TC1276 have an active-low RESET output. TC1275 and TC1277 each have a complimentary output while the TC1276 has an open drain output. The output of the TC1275 and TC1276 is valid down to $V_{CC} = 1.2V$. The TC1277 is valid down to $V_{CC} = 1.8V$. All three devices are available in a 3-Pin SOT-23 package.

The TC1275/TC1276/TC1277 devices are optimized to reject fast transient glitches on the V_{CC} line.

Typical Operating Circuit

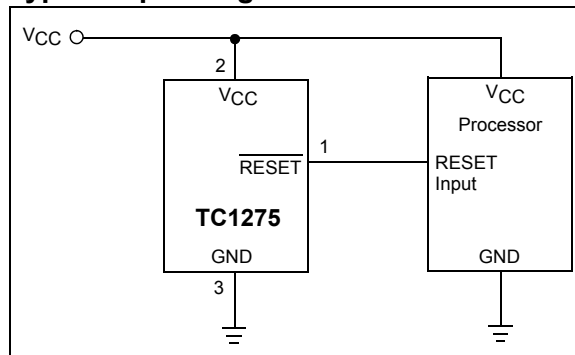

TC1275/TC1276/TC1277

1.0 ELECTRICAL CHARACTERISTICS

Absolute Maximum Ratings*

Supply Voltage (V_{CC} to GND)	+6.0V
RESET, RESET	-0.3V to ($V_{CC} + 0.3V$)
Input Current, V_{CC}	20 mA
Output Current, $\overline{\text{RESET}}$, RESET	20 mA
Power Dissipation ($T_A \leq 70^\circ\text{C}$)	
3-Pin SOT-23 (derate 4 mW/ $^\circ\text{C}$ above $+70^\circ\text{C}$)	
.....	230 mW
Operating Temperature Range	-40°C to $+85^\circ\text{C}$
Storage Temperature Range	-65°C to $+150^\circ\text{C}$

*Stresses above those listed under "Absolute Maximum Ratings" may cause permanent damage to the device. These are stress ratings only and functional operation of the device at these or any other conditions above those indicated in the operation sections of the specifications is not implied. Exposure to Absolute Maximum Rating conditions for extended periods may affect device reliability.

TC1275/TC1276/TC1277 ELECTRICAL SPECIFICATIONS

Recommended DC Operating Conditions: $T_A = -40^\circ\text{C}$ to $+85^\circ\text{C}$ unless otherwise noted. Typical values are at $T_A = +25^\circ\text{C}$.							
Symbol	Parameter	Min	Typ	Max	Units	Device	Test Conditions
V_{CC}	Supply Voltage	1.2 1.8	— —	5.5 5.5	V	TC1275, TC1276 TC1277	Note 1
DC Electrical Characteristics: $T_A = -40^\circ\text{C}$ to $+85^\circ\text{C}$ unless otherwise noted. Typical values are at $T_A = +25^\circ\text{C}$.							
Symbol	Parameter	Min	Typ	Max	Units		Test Conditions
V_{OH}	Output Voltage @ 0-500 μA	$V_{CC} - 0.5V$	$V_{CC} - 0.1V$	—	V	TC1275, TC1277	Note 1
I_{OH}	Output Current @ 2.4 Volts	—	13	—	mA	TC1275	Note 2
	$V_{CC} = 5V$	—	1.3	—		TC1277	
	$V_{CC} = 2.7V$						
I_{OL}	Output Current @ 0.4 Volts	+10	30	—	mA		Note 2, Note 5
I_{CC}	Operating Current	—	20	35	μA	TC1275, TC1277	Note 3
	$V_{CC} < 5.5V$	—	20	35		TC1276	Note 3
	$V_{CCTP} < V_{CC} < 5.5V$	—	350	700		TC1276	Note 3
V_{CCTP-5}	V_{CC} Trip Point (TC1275/6/7-5)	2.98	3.06	3.15	V		Note 1
$V_{CCTP-10}$	V_{CC} Trip Point (TC1275/6/7-10)	2.80	2.88	2.97	V		Note 1
$V_{CCTP-20}$	V_{CC} Trip Point (TC1275/6/7-20)	2.47	2.55	2.64	V		Note 1
C_{OUT}	Output Capacitance	—	9	—	pF		
R_P	Internal Pull-Up Resistor	3.0	6.0	9.0	k Ω	TC1276	
AC Electrical Characteristics: $T_A = -40^\circ\text{C}$ to $+85^\circ\text{C}$ unless otherwise noted. Typical values are at $T_A = +25^\circ\text{C}$.							
Symbol	Parameter	Min	Typ	Max	Units		Test Conditions
t_{RST}	RESET Active Time	100	200	300	ms		
t_{RPD1}	V_{CC} Detect to RESET	—	20	50	μs	TC1275, TC1276	$V_{CC(Low)} = 1V$, Figure 3-2
t_{RPD2}	V_{CC} Detect to RESET	—	20	50	μs	TC1277	$V_{CC(Low)} = 1V$, Figure 3-4
t_F	V_{CC} Slew Rate ($V_{CCTP(MAX)}$ to $V_{CCTP(MIN)}$)	300	—	—	μs		Figure 3-2, Figure 3-4
t_R	V_{CC} Slew Rate ($V_{CCTP(MIN)}$ to $V_{CCTP(MAX)}$)	0	—	—	ns		Figure 3-1, Figure 3-3
t_{RPU1}	V_{CC} Detect to RESET	100	200	300	ms	TC1275, TC1276	Note 4, Figure 3-1
t_{RPU2}	V_{CC} Detect to RESET	100	200	300	ms	TC1277	Note 4, Figure 3-3

- Note**
- 1: All voltages referenced to ground.
 - 2: Measured with $V_{CC} \geq 2.7$ volts.
 - 3: Measured with RESET output open for TC1275/TC1276; measured with RESET output open for TC1277.
 - 4: $t_R = 5 \mu\text{s}$.
 - 5: A 1 k Ω external resistor may be required in some applications for proper operation of the microprocessor reset control circuit when using the TC1276.

TC1275/TC1276/TC1277

2.0 PIN DESCRIPTIONS

The descriptions of the pins are listed in Table 2-1.

TABLE 2-1: PIN FUNCTION TABLE

Pin No. (3-Pin SOT-23)	Symbol	Description
1	$\overline{\text{RESET}}$ (TC1275/ TC1276)	RESET output remains low while V_{CC} is below the reset voltage threshold, and for 200 ms (100 ms minimum) after V_{CC} rises above reset threshold. The output stage of the TC1275 is complimentary. The output stage of the TC1276 is open-drain.
1	RESET (TC1277)	RESET output remains high while V_{CC} is below the reset voltage threshold, and for 200 ms (100 ms minimum) after V_{CC} rises above reset threshold. The output stage of the TC1277 is complimentary.
2	V_{CC}	Supply voltage (1.2V to 5.5V TC1275 and TC1276, 1.8V to 5.5V TC1277).
3	GND	Ground.

TC1275/TC1276/TC1277

3.0 APPLICATIONS INFORMATION

3.1 Operation – Power Monitor

The TC1275/TC1276/TC1277 provide the function of detecting out-of-tolerance power supply conditions and warning a processor-based system of impending power failure. When V_{CC} is detected as out-of-tolerance, the RESET signal is asserted. On power-up, RESET is kept active for approximately 200 ms after the power supply has reached the selected tolerance. This allows the power supply and microprocessor to stabilize before RESET is released.

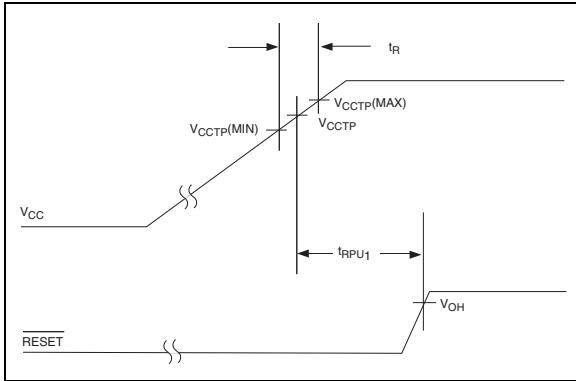

FIGURE 3-1: Timing Diagram – Power Up (TC1275/TC1276).

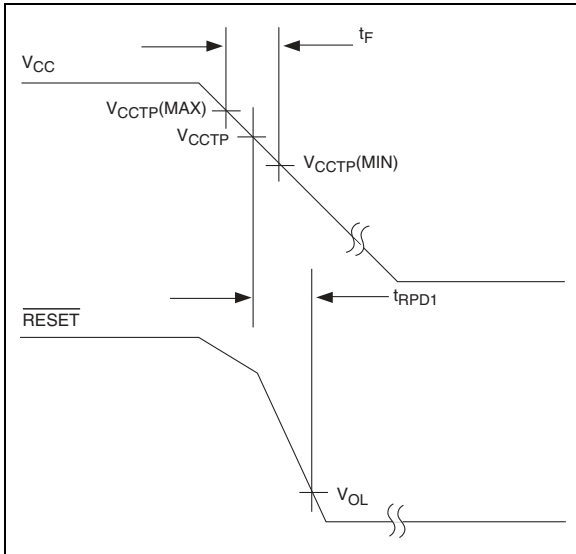

FIGURE 3-2: Timing Diagram – Power Down (TC1275/TC1276).

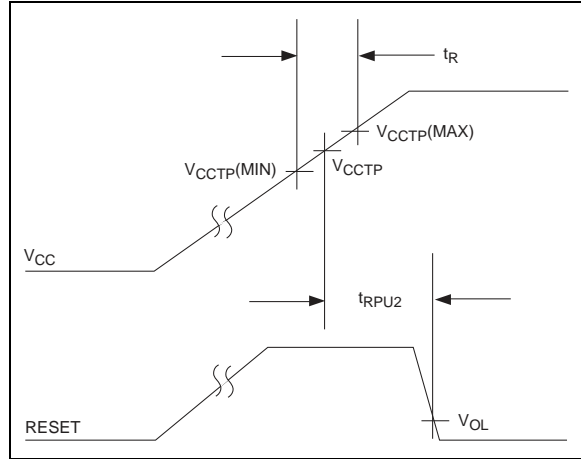

FIGURE 3-3: Timing Diagram – Power Up (TC1277).

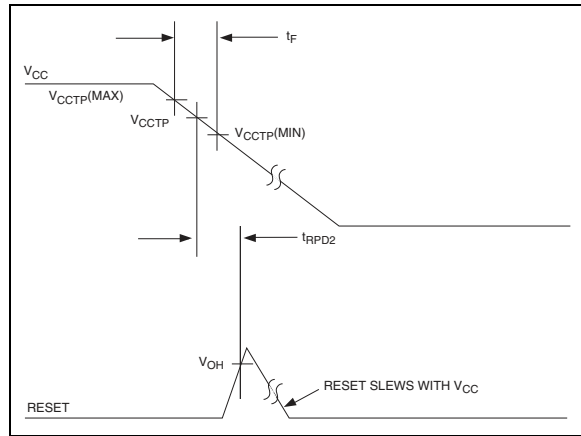

FIGURE 3-4: Timing Diagram – Power Down (TC1277).

3.2 V_{CC} Transient Rejection

The TC1275/TC1276/TC1277 provides accurate V_{CC} monitoring and reset timing during power-up, power-down, and brownout/sag conditions, and rejects negative-going transients (glitches) on the power supply line. Figure 3-5 shows the maximum transient duration vs. maximum negative excursion (overdrive) for glitch rejection. Any combination of duration and overdrive that lays **under** the curve will **not** generate a reset signal. Combinations above the curve are detected as a brownout or power-down. Transient immunity can be improved by adding a capacitor in close proximity to the V_{CC} pin of the TC1275/TC1276/TC1277.

3.3 RESET Signal Integrity During Power-Down

The TC1275 $\overline{\text{RESET}}$ output is valid to V_{CC} = 1.2V. Below this voltage the output becomes an "open circuit" and does not sink current. This means CMOS logic inputs to the μP will be floating at an undetermined voltage. Most digital systems are completely shut down well above this voltage. However, in situations where $\overline{\text{RESET}}$ must be maintained valid to V_{CC} = 0V, a pull-down resistor must be connected from $\overline{\text{RESET}}$ to ground to discharge stray capacitances and hold the output low (Figure 3-6). This resistor value, though not critical, should be chosen such that it does not appreciably load $\overline{\text{RESET}}$ under normal operation (100 k Ω will be suitable for most applications). Similarly, a pull-up resistor to V_{CC} is required for the TC1277 to ensure a valid high $\overline{\text{RESET}}$ for V_{CC} below 1.8V.

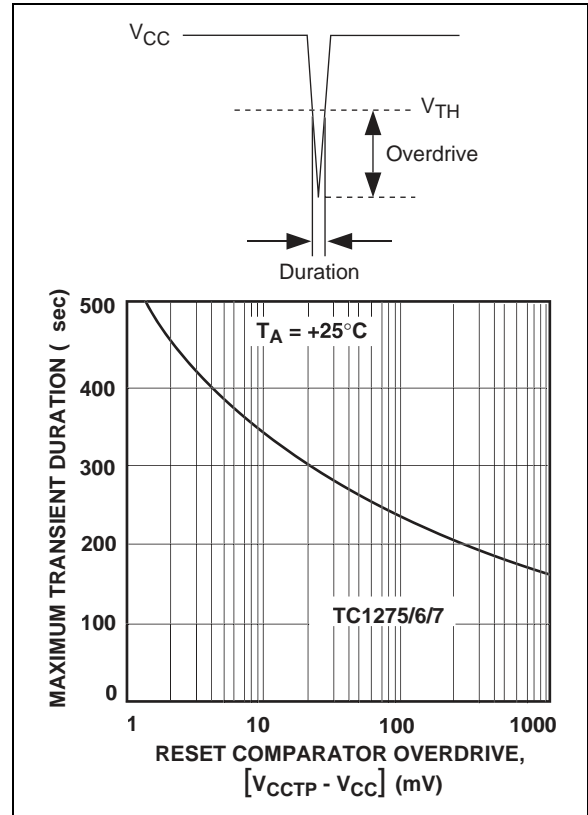

FIGURE 3-5: Maximum Transient Duration Vs. Overdrive For Glitch Rejection At +25°C.

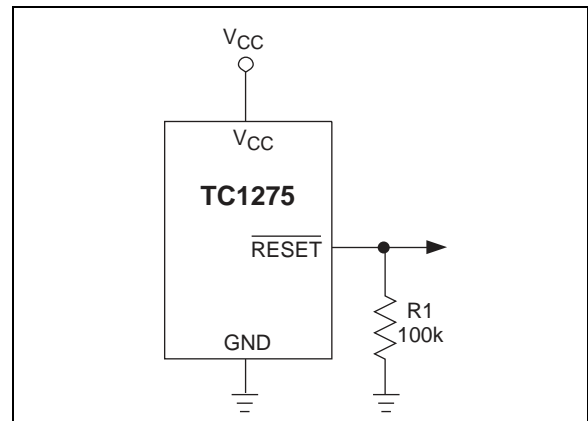
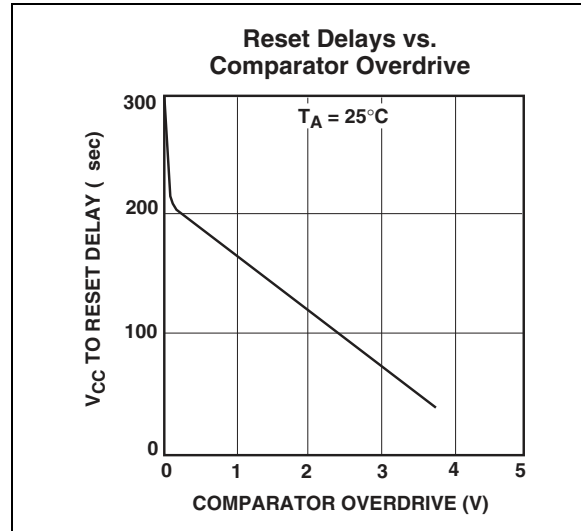
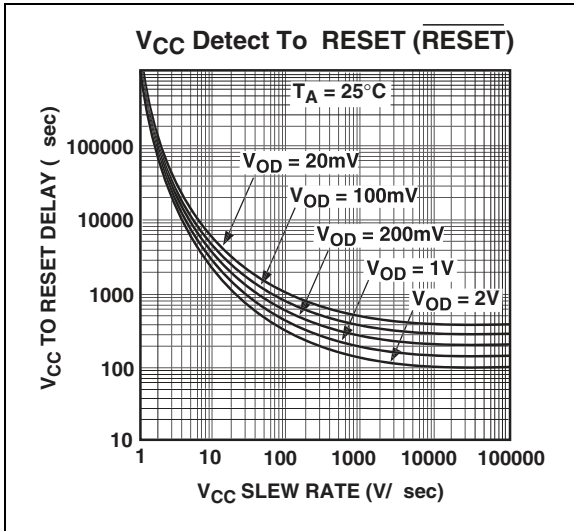

FIGURE 3-6: ENSURING $\overline{\text{RESET}}$ VALID TO V_{CC} = 0V.

TC1275/TC1276/TC1277

4.0 TYPICAL CHARACTERISTICS

Note: The graphs and tables provided following this note are a statistical summary based on a limited number of samples and are provided for informational purposes only. The performance characteristics listed herein are not tested or guaranteed. In some graphs or tables, the data presented may be outside the specified operating range (e.g., outside specified power supply range) and therefore outside the warranted range.



TC1275/TC1276/TC1277

5.0 PACKAGING INFORMATION

5.1 Package Marking Information

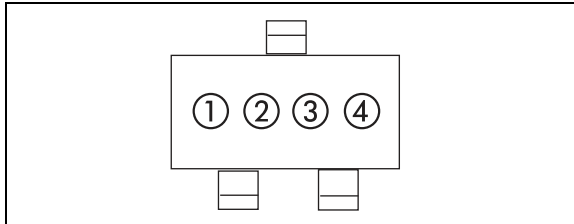

① & ② = part number code + temperature range and voltage

TC1275 (V)	Code
2.55	DA
2.88	DB
3.06	DC

TC1276 (V)	Code
2.55	EA
2.88	EB
3.06	EC

TC1277 (V)	Code
2.55	FA
2.88	FB
3.06	FC

ex: 1275-20 = ① ② ③ ④

③ represents year and quarter code

④ represents production lot ID code

TC1275/TC1276/TC1277

3-Lead Plastic Small Outline Transistor (TT or NB) [SOT-23]

Note: For the most current package drawings, please see the Microchip Packaging Specification located at <http://www.microchip.com/packaging>

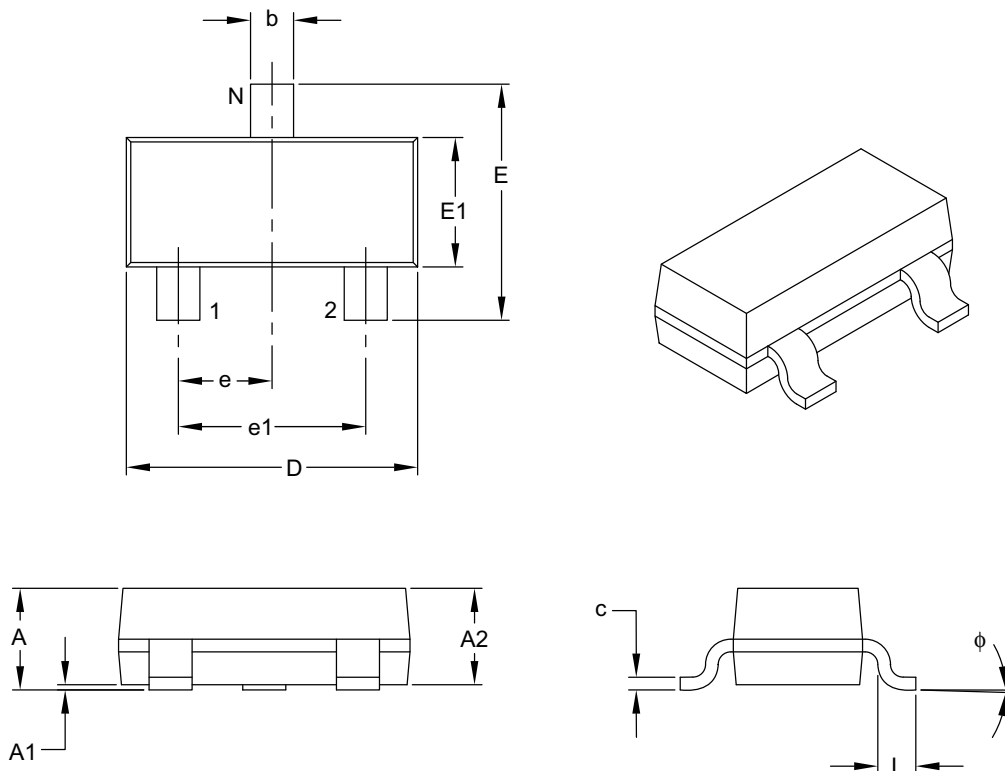

Dimension Limits	Units	MILLIMETERS		
		MIN	NOM	MAX
Number of Pins	N	3		
Lead Pitch	e	0.95 BSC		
Outside Lead Pitch	e1	1.90 BSC		
Overall Height	A	0.89	–	1.12
Molded Package Thickness	A2	0.79	0.95	1.02
Standoff	A1	0.01	–	0.10
Overall Width	E	2.10	–	2.64
Molded Package Width	E1	1.16	1.30	1.40
Overall Length	D	2.67	2.90	3.05
Foot Length	L	0.13	0.50	0.60
Foot Angle	ϕ	0°	–	10°
Lead Thickness	c	0.08	–	0.20
Lead Width	b	0.30	–	0.54

Notes:

1. Dimensions D and E1 do not include mold flash or protrusions. Mold flash or protrusions shall not exceed 0.25 mm per side.

2. Dimensioning and tolerancing per ASME Y14.5M.

BSC: Basic Dimension. Theoretically exact value shown without tolerances.

Microchip Technology Drawing C04-104B

TC1275/TC1276/TC1277

PRODUCT IDENTIFICATION SYSTEM

To order or obtain information, e.g., on pricing or delivery, refer to the factory or the listed sales office.

<u>PART NO.</u>	<u>XX</u>	<u>X</u>	<u>/XX</u>
Device	Reset V _{CC} Threshold	Temperature Range	Package
Device:	TC1275:	3-Pin Reset Monitor - Complementary	
	TC1276:	3-Pin Reset Monitor - Open-Drain	
	TC1277:	3-Pin Reset Monitor - Complementary	
Reset V _{CC} Threshold Voltage	5	= 3.06V	
	10	= 2.88V	
	15	= 2.55V	
Temperature Range:	E	= -40°C to +85°C	
Package:	NB	= Plastic Small Outline Transistor (SOT-23), 3-lead	

Examples:

a) TC1275-10ENBTR: 2.88V Reset Monitor
 b) TC1275-15ENBTR: 2.55V Reset Monitor
 c) TC1275-5ENBTR: 3.06V Reset Monitor

a) TC1276-10ENBTR: 2.88V Reset Monitor
 b) TC1276-15ENBTR: 2.55V Reset Monitor
 c) TC1276-5ENBTR: 3.06V Reset Monitor

a) TC1277-10ENBTR: 2.88V Reset Monitor
 b) TC1277-15ENBTR: 2.55V Reset Monitor
 c) TC1277-5ENBTR: 3.06V Reset Monitor

TC1275/TC1276/TC1277

NOTES:

Note the following details of the code protection feature on Microchip devices:

- Microchip products meet the specification contained in their particular Microchip Data Sheet.
- Microchip believes that its family of products is one of the most secure families of its kind on the market today, when used in the intended manner and under normal conditions.
- There are dishonest and possibly illegal methods used to breach the code protection feature. All of these methods, to our knowledge, require using the Microchip products in a manner outside the operating specifications contained in Microchip's Data Sheets. Most likely, the person doing so is engaged in theft of intellectual property.
- Microchip is willing to work with the customer who is concerned about the integrity of their code.
- Neither Microchip nor any other semiconductor manufacturer can guarantee the security of their code. Code protection does not mean that we are guaranteeing the product as “unbreakable.”

Code protection is constantly evolving. We at Microchip are committed to continuously improving the code protection features of our products. Attempts to break Microchip's code protection feature may be a violation of the Digital Millennium Copyright Act. If such acts allow unauthorized access to your software or other copyrighted work, you may have a right to sue for relief under that Act.

Information contained in this publication regarding device applications and the like is provided only for your convenience and may be superseded by updates. It is your responsibility to ensure that your application meets with your specifications. MICROCHIP MAKES NO REPRESENTATIONS OR WARRANTIES OF ANY KIND WHETHER EXPRESS OR IMPLIED, WRITTEN OR ORAL, STATUTORY OR OTHERWISE, RELATED TO THE INFORMATION, INCLUDING BUT NOT LIMITED TO ITS CONDITION, QUALITY, PERFORMANCE, MERCHANTABILITY OR FITNESS FOR PURPOSE. Microchip disclaims all liability arising from this information and its use. Use of Microchip devices in life support and/or safety applications is entirely at the buyer's risk, and the buyer agrees to defend, indemnify and hold harmless Microchip from any and all damages, claims, suits, or expenses resulting from such use. No licenses are conveyed, implicitly or otherwise, under any Microchip intellectual property rights.

Trademarks

The Microchip name and logo, the Microchip logo, Accuron, dsPIC, KEELOQ, KEELOQ logo, microID, MPLAB, PIC, PICmicro, PICSTART, PRO MATE, PowerSmart, rPIC, and SmartShunt are registered trademarks of Microchip Technology Incorporated in the U.S.A. and other countries.

AmpLab, FilterLab, Linear Active Thermistor, Migratable Memory, MXDEV, MXLAB, PS logo, SEEVAL, SmartSensor and The Embedded Control Solutions Company are registered trademarks of Microchip Technology Incorporated in the U.S.A.

Analog-for-the-Digital Age, Application Maestro, CodeGuard, dsPICDEM, dsPICDEM.net, dsPICworks, ECAN, ECONOMONITOR, FanSense, FlexROM, fuzzyLAB, In-Circuit Serial Programming, ICSP, ICEPIC, Mindi, MiWi, MPASM, MPLAB Certified logo, MPLIB, MPLINK, PICkit, PICDEM, PICDEM.net, PICLAB, PICtail, PowerCal, PowerInfo, PowerMate, PowerTool, REAL ICE, rLAB, rfPICDEM, Select Mode, Smart Serial, SmartTel, Total Endurance, UNI/O, WiperLock and ZENA are trademarks of Microchip Technology Incorporated in the U.S.A. and other countries.

SQTP is a service mark of Microchip Technology Incorporated in the U.S.A.

All other trademarks mentioned herein are property of their respective companies.

© 2007, Microchip Technology Incorporated, Printed in the U.S.A., All Rights Reserved.

 Printed on recycled paper.

Microchip received ISO/TS-16949:2002 certification for its worldwide headquarters, design and wafer fabrication facilities in Chandler and Tempe, Arizona, Gresham, Oregon and Mountain View, California. The Company's quality system processes and procedures are for its PIC® MCUs and dsPIC® DSCs, KEELOQ® code hopping devices, Serial EEPROMs, microperipherals, nonvolatile memory and analog products. In addition, Microchip's quality system for the design and manufacture of development systems is ISO 9001:2000 certified.

**QUALITY MANAGEMENT SYSTEM
CERTIFIED BY DNV
== ISO/TS 16949:2002 ==**



WORLDWIDE SALES AND SERVICE

AMERICAS

Corporate Office
2355 West Chandler Blvd.
Chandler, AZ 85224-6199
Tel: 480-792-7200
Fax: 480-792-7277
Technical Support:
<http://support.microchip.com>
Web Address:
www.microchip.com

Atlanta
Duluth, GA
Tel: 678-957-9614
Fax: 678-957-1455

Boston
Westborough, MA
Tel: 774-760-0087
Fax: 774-760-0088

Chicago
Itasca, IL
Tel: 630-285-0071
Fax: 630-285-0075

Dallas
Addison, TX
Tel: 972-818-7423
Fax: 972-818-2924

Detroit
Farmington Hills, MI
Tel: 248-538-2250
Fax: 248-538-2260

Kokomo
Kokomo, IN
Tel: 765-864-8360
Fax: 765-864-8387

Los Angeles
Mission Viejo, CA
Tel: 949-462-9523
Fax: 949-462-9608

Santa Clara
Santa Clara, CA
Tel: 408-961-6444
Fax: 408-961-6445

Toronto
Mississauga, Ontario,
Canada
Tel: 905-673-0699
Fax: 905-673-6509

ASIA/PACIFIC

Asia Pacific Office
Suites 3707-14, 37th Floor
Tower 6, The Gateway
Harbour City, Kowloon
Hong Kong
Tel: 852-2401-1200
Fax: 852-2401-3431

Australia - Sydney
Tel: 61-2-9868-6733
Fax: 61-2-9868-6755

China - Beijing
Tel: 86-10-8528-2100
Fax: 86-10-8528-2104

China - Chengdu
Tel: 86-28-8665-5511
Fax: 86-28-8665-7889

China - Fuzhou
Tel: 86-591-8750-3506
Fax: 86-591-8750-3521

China - Hong Kong SAR
Tel: 852-2401-1200
Fax: 852-2401-3431

China - Qingdao
Tel: 86-532-8502-7355
Fax: 86-532-8502-7205

China - Shanghai
Tel: 86-21-5407-5533
Fax: 86-21-5407-5066

China - Shenyang
Tel: 86-24-2334-2829
Fax: 86-24-2334-2393

China - Shenzhen
Tel: 86-755-8203-2660
Fax: 86-755-8203-1760

China - Shunde
Tel: 86-757-2839-5507
Fax: 86-757-2839-5571

China - Wuhan
Tel: 86-27-5980-5300
Fax: 86-27-5980-5118

China - Xian
Tel: 86-29-8833-7250
Fax: 86-29-8833-7256

ASIA/PACIFIC

India - Bangalore
Tel: 91-80-4182-8400
Fax: 91-80-4182-8422

India - New Delhi
Tel: 91-11-4160-8631
Fax: 91-11-4160-8632

India - Pune
Tel: 91-20-2566-1512
Fax: 91-20-2566-1513

Japan - Yokohama
Tel: 81-45-471-6166
Fax: 81-45-471-6122

Korea - Gumi
Tel: 82-54-473-4301
Fax: 82-54-473-4302

Korea - Seoul
Tel: 82-2-554-7200
Fax: 82-2-558-5932 or
82-2-558-5934

Malaysia - Penang
Tel: 60-4-646-8870
Fax: 60-4-646-5086

Philippines - Manila
Tel: 63-2-634-9065
Fax: 63-2-634-9069

Singapore
Tel: 65-6334-8870
Fax: 65-6334-8850

Taiwan - Hsin Chu
Tel: 886-3-572-9526
Fax: 886-3-572-6459

Taiwan - Kaohsiung
Tel: 886-7-536-4818
Fax: 886-7-536-4803

Taiwan - Taipei
Tel: 886-2-2500-6610
Fax: 886-2-2508-0102

Thailand - Bangkok
Tel: 66-2-694-1351
Fax: 66-2-694-1350

EUROPE

Austria - Wels
Tel: 43-7242-2244-39
Fax: 43-7242-2244-393

Denmark - Copenhagen
Tel: 45-4450-2828
Fax: 45-4485-2829

France - Paris
Tel: 33-1-69-53-63-20
Fax: 33-1-69-30-90-79

Germany - Munich
Tel: 49-89-627-144-0
Fax: 49-89-627-144-44

Italy - Milan
Tel: 39-0331-742611
Fax: 39-0331-466781

Netherlands - Drunen
Tel: 31-416-690399
Fax: 31-416-690340

Spain - Madrid
Tel: 34-91-708-08-90
Fax: 34-91-708-08-91

UK - Wokingham
Tel: 44-118-921-5869
Fax: 44-118-921-5820