

**LANTRONIX<sup>®</sup>**

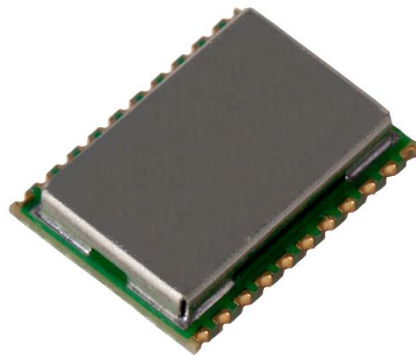

# **GPS/GLONASS Receiver Module A5100-A User Guide**

Part Number PMD-00033  
Revision A November 2019

---

## Intellectual Property

© 2019 Lantronix, Inc. All rights reserved. No part of the contents of this publication may be transmitted or reproduced in any form or by any means without the written permission of Lantronix.

*Lantronix* is a registered trademark of Lantronix, Inc. in the United States and other countries.

Patented: [www.lantronix.com/legal/patents/](http://www.lantronix.com/legal/patents/). Additional patents pending.

*Windows* and *Internet Explorer* are registered trademarks of Microsoft Corporation. *Firefox* is a registered trademark of the Mozilla Foundation. *Chrome* is a trademark of Google Inc. All other trademarks and trade names are the property of their respective holders.

## Warranty

For details on the Lantronix warranty policy, please go to our web site at [www.lantronix.com/support/warranty/](http://www.lantronix.com/support/warranty/)

## Contacts

### Lantronix, Inc.

7535 Irvine Center Drive, Suite 100  
Irvine, CA 92618, USA  
Toll Free: 800-526-8766  
Phone: 949-453-3990  
Fax: 949-453-3995

### Technical Support

Online: [www.lantronix.com/support](http://www.lantronix.com/support)

### Sales Offices

For a current list of our domestic and international sales offices, go to the Lantronix web site at [www.lantronix.com/about-us/contact/](http://www.lantronix.com/about-us/contact/)

## Disclaimer

All information contained herein is provided "AS IS." Lantronix undertakes no obligation to update the information in this publication. Lantronix does not make, and specifically disclaims, all warranties of any kind (express, implied or otherwise) regarding title, non-infringement, fitness, quality, accuracy, completeness, usefulness, suitability or performance of the information provided herein. Lantronix shall have no liability whatsoever to any user for any damages, losses and causes of action (whether in contract or in tort or otherwise) in connection with the user's access or usage of any of the information or content contained herein. The information and specifications contained in this document are subject to change without notice.

---

## Open Source Software

Some applications are Open Source software licensed under the Berkeley Software Distribution (BSD) license, the GNU General Public License (GPL) as published by the Free Software Foundation (FSF), or the Python Software Foundation (PSF) License Agreement for Python 2.7.3 (Python License). Lantronix grants you no right to receive source code to the Open Source software; however, in some cases, rights and access to source code for certain Open Source software may be available directly from Lantronix' licensors. The BSD license is available at <http://opensource.org/licenses>. The GNU General Public License is available at <http://www.gnu.org/licenses/>. The Python License is available at <http://cmpt165.csil.sfu.ca/Python-Docs/license.html>. Your use of each Open Source component or software is subject to the terms of the applicable license.

OPEN SOURCE SOFTWARE IS DISTRIBUTED WITHOUT ANY WARRANTY, INCLUDING ANY IMPLIED WARRANTY OF MERCHANTABILITY OR FITNESS FOR A PARTICULAR PURPOSE. SEE THE APPLICABLE LICENSE AGREEMENT FOR ADDITIONAL INFORMATION.

You may request a list of the open source components and the licenses that apply to them. Contact your regional Lantronix sales associate. [www.lantronix.com/about-us/contact/](http://www.lantronix.com/about-us/contact/)

## Revision History

Date	Rev.	Comments
October 2013	0.1	First draft.
February 2014	0.2	Updates according to DV samples.
November 2019	A	Added Lantronix document part number, Lantronix logo, branding, contact information, and links.

For the latest revision of this product document, please check our online documentation at [www.lantronix.com/support/documentation](http://www.lantronix.com/support/documentation).

---

## Table of Contents

Intellectual Property	1
Warranty	2
Contacts	2
Disclaimer	2
Open Source Software	3
Revision History	3
Table of Contents	4
List of Figures	6
List of Tables	7
<b>1 Introduction</b>	<b>8</b>
1.1 Feature Overview	8
1.2 Characteristics Overview	9
1.3 RoHS and Lead-Free Information	9
1.4 Label	10
1.5 Characteristics	11
1.5.1 GPS & GLONASS Characteristics	11
1.5.2 Mechanical Characteristics	11
1.6 Handling Precautions	11
<b>2 Ordering Information</b>	<b>12</b>
2.1 GPS/GLONASS Receiver A5100-A	12
2.2 Packing of the A5100-A	12
2.3 Additional Equipment	14
<b>3 Quick Start</b>	<b>15</b>
3.1 Minimum Configuration	15
3.2 Antennas	17
3.2.1 Passive Antennas	17
3.2.2 Active Antennas	17
3.3 Serial Port Settings	18
3.3.1 Change Serial Port setting	18
3.4 Improved TTFF	18
3.5 Self-start Configuration	19
<b>4 Mechanical Outline</b>	<b>21</b>
4.1 Details Component Side A5100-A	21
4.2 Details Solder Side A5100-A	22
<b>5 Pin-out Information</b>	<b>23</b>
5.1 Layout A5100-A	23
5.2 Description A5100-A Signals	24

---

<b>6 Electrical Characteristics</b>	<b>26</b>
6.1 Operating Conditions _____	26
6.2 Absolute Maximum Ratings _____	27
6.3 DC Electrical Characteristics _____	28
<b>7 Mounting</b>	<b>29</b>
7.1 Proposed Footprint for Soldering _____	29
7.2 Recommended Profile for Reflow Soldering _____	30
<b>8 Use of GPS &amp; GLONASS Antennas</b>	<b>31</b>
8.1 Connecting a GPS & GLONASS antenna to the GPS & GLONASS receiver _____	31
8.2 Antenna Connections _____	33
8.2.1 Passive Antennas _____	33
8.2.2 Active Antennas _____	33
<b>9 Quality and Reliability</b>	<b>34</b>
9.1 Environmental Conditions _____	34
9.2 Product Qualification _____	34
9.3 Production Test _____	34
<b>10 Applications and Hints</b>	<b>35</b>
10.1 Initial Module Start _____	35
10.2 Proper Shutdown _____	35
10.3 SiRFaware™ Support _____	35
10.4 Push-to-Fix Mode _____	35
10.5 Hibernate Mode _____	35
10.6 Battery Back-up _____	37
10.7 Extended Ephemeris _____	38
10.8 Antenna Status Adaptation _____	39
10.8.1 Antenna Sensor _____	39
10.8.2 Antenna Sensor with Current Limiter _____	40
10.9 VANT Pin _____	41
10.10 TM_GPIO5 pin (1 pulse per second pin) _____	41
10.11 5 Hz Navigation Update Rate _____	42
<b>11 Evaluation Kit EVA5100-A</b>	<b>43</b>
<b>12 Related Information</b>	<b>44</b>
12.1 Related Documents _____	44
12.2 Related Tools _____	44

---

## List of Figures

Figure 1: A5100-A label.....	10
Figure 2: A5100-A tape specifications (1) .....	12
Figure 3: A5100-A tape specifications (2) .....	13
Figure 4: A5100-A tape specifications (3) .....	13
Figure 5: Minimum configuration A5100-A with continued Vcc supply .....	15
Figure 6: Minimum configuration A5100-A with VBak .....	16
Figure 7: RS232 level shifter .....	17
Figure 8: Self-start configuration A5100-A .....	19
Figure 9: Self-start configuration A5100-A with Vbak.....	20
Figure 10: Mechanical outline component side A5100-A .....	21
Figure 11: Mechanical outline solder side A5100-A .....	22
Figure 12: Pin-out information (bottom view) A5100-A.....	23
Figure 13: Recommended Solder PAD Layout .....	29
Figure 14: Antenna connector strip line A5100-A.....	31
Figure 15: Strip line parameters A5100-A .....	31
Figure 16: Strip line parameters A5100-A .....	37
Figure 17: Application note: Antenna sensor adaptation .....	39
Figure 18: Application note: Antenna sensor adaptation with current limiter .....	40
Figure 19: 1PPS waveform (reference) .....	42
Figure 20: Evaluation kit EVA5100-A .....	43

---

## List of Tables

Table 1: A5100-A GPS&GLONASS characteristics .....	11
Table 2: A5100-A dimensions and weight .....	11
Table 3: Additional equipment .....	14
Table 4: Set Serial Port Data Format .....	18
Table 5: Pin description A5100-A .....	25
Table 6: A5100-A electrical characteristics .....	26
Table 7: Absolute maximum ratings .....	27
Table 8: DC electrical characteristic A5100-A .....	28
Table 9: Reflow soldering profile A5100-A .....	30
Table 10: Environmental conditions .....	34

# 1 Introduction

A5100-A is a compact high sensitivity concurrent GNSS module that integrates CSR's latest SiRFstarV technology into a single and easy to integrate SMT device. By supporting simultaneous GLONASS, GPS, QZSS and SBAS measurements with the industry's best sensitivity engine, the highest accuracy, ground tracks and fastest time-to-first-fix (TTFF) are ensured even under tough operating conditions. The jammers removal algorithm not only facilitates integration in today's ever more complex communication devices, but guarantees performance even in hostile situations. SiRFaware's advanced low power management modes, high level of integration and multiple communication ports in a small form-factor makes the A5100-A suitable for a broad spectrum of GPS applications where performance, cost and time to market are prime considerations.

A5100-A is a drop-in replacement solution for all A2200-A customers. It is housed in a 15.0 x 10.2 x 2.5 mm 22 pins SMD package with castellated edge that includes the SiRFStarV (CSRG05e) chipset, referred to later as SS5e, built-in SPI Flash, all RF matching elements, antenna DC control, RF SAW filtering, various thermal and peripheral components and the TCXO crystal reference. A very easy implementation (power, serial, ON\_OFF, and antenna) allows receiving position, velocity and time information.

A5100-A is designed for 3.3V power supply.

## 1.1 Feature Overview

The A5100-A is based on the well-established A2200-A outline and offering new outstanding features, especially GLONASS reception.

- Fast, responsive location experience
  - High-sensitive navigation engine with tracking down to -165dBm
  - 52 track verification channels
  - SBAS (WAAS, EGNOS, MSAS, GAGAN)
  - Concurrent tracking of multiple constellations of the GPS and GLONASS systems
- Breakthrough micro power technology
  - Requires only 50 – 500µA to maintain hot start capability
- Internal Power-On-Reset (POR) reset chipset to prevent memory corruption if main power removal abruptly
- Active CW interference rejection
- SiRFInstantFix™ extended ephemeris aiding – CGEE and SGEE



## 1.2 Characteristics Overview

The module's most important characteristics are:

- A5100-A
  - Operable at 3.3V / 31mA (typ.) @ 1 fix per second
  - V\_BAK at 3.0V / 60uA (typ.)
  - UART interface at 3.3V CMOS level
  - SPI Slave support at 3.3V CMOS level
  - I<sup>2</sup>C Multi-master operation at 3.3V CMOS level
- Internal 4 Mb SPI Flash
- Direct passive antenna support
- Switched antenna voltage for active antenna support
- Small form factor of 10.2 mm x 15.0 mm (0.40" x 0.59"), 1mm longer than A2200-A but they are drop-in replaceable
- Supported temperature range: -40°C to +85°C
- Single-sided SMT component, for reflow soldering
- Tape & reel packaging

The A5100-A receiver modules is available as off-the-shelf components, 100% tested and shipped in standard tape-and-reel package.

## 1.3 RoHS and Lead-Free Information

Lantronix's products marked with the lead-free symbol either on the module or the packaging comply with the "Directive 2002/95/EC of the European Parliament and the Council on the Restriction of Use of certain Hazardous Substances in Electrical and Electronic Equipment" (RoHS).



All Lantronix GPS/GLONASS receiver modules, smart GPS or GPS&GLONASS antenna modules and telematics units are RoHS compliant.

## 1.4 Label

The A5100-A labels hold the following information:



Figure 1: A5100-A label

The label is placed on the shield of the module. The data matrix code holds the product type, part number, patch release, hardware release, factory code, year & week of assembly and a 6-digit serial number.

Representing	Factory code	Product Number	Part Number	Patch Release	Hardware Release	Assembly Year/Week	Serial Number
Number of digits (27)	XX 2	XXXXXX 6	XXXXX 5	XX 2	XX 2	XXXX 4	XXXXXX 6
Example	TF	A5100A	30B01	01	01	1332	000005
Meaning	TF	Given	Given	Given	Given	Year=13 Week=32	Increment from 000001 up to 999999

Example of MID#: TFA5100A30B0101011332000005

**NOTE:** Hardware revision (rr) of the series product starts with 01. A hardware revision above 50 shows the module was produced before the product was fully qualified (Engineering Samples).

## 1.5 Characteristics

The modules are characterized by the following parameters.

### 1.5.1 GPS & GLONASS Characteristics

Channels	52, parallel tracking	
Correlators	~ 400,000	
Frequency	GPS	L1 (= 1,575 MHz)
	GLONASS	FDM L1 (=1,602 MHz)
Tracking Sensitivity <sup>(1)</sup>	GPS & GLONASS	-165 dBm
Horizontal Position Accuracy	Stand alone	< 2.5 m CEP (SA off)
Time To First Fix – TTFF (theoretical minimum values; values in real world may differ)	Obscuration recovery <sup>(2)</sup>	0.1 s
	Hot start <sup>(3)</sup>	< 1 s
	Warm <sup>(4)</sup>	< 30 s
	Cold <sup>(5)</sup>	< 35 s

Table 1: A5100-A GPS&GLONASS characteristics

- (1) Typical with good antenna – see also paragraph “3.2 Antennas”
- (2) The calibrated clock of the receiver has not stopped, thus it knows precise time (to the  $\mu$ s level).
- (3) The receiver has estimates of time/date/position and valid almanac and ephemeris data.
- (4) The receiver has estimates of time/date/position and recent almanac.
- (5) The receiver has no estimate of time/date/position, and no recent almanac.

Note: Performance (sensitivity and TTFF) might slightly decrease below -30°C.

### 1.5.2 Mechanical Characteristics

A5100-A Mechanical dimensions	Length	10.2±0.20 mm, 0.4±0.008"
	Width	15.24±0.20 mm, 0.59±0.008"
	Height	2.5 mm, 0.1" (Max)
A5100-A Weight		0.6 g, 0.022 oz

Table 2: A5100-A dimensions and weight

## 1.6 Handling Precautions

The GPS/GLONASS receiver module A5100-A is sensitive to electrostatic discharge (ESD). Please handle with appropriate care.

## 2 Ordering Information

### 2.1 GPS/GLONASS Receiver A5100-A

The order number is built as follows:

- **A5100-Axxxxxxx**

A5100-A is the model name. The “xxxxxxx” refers to the current chipset and patch (if appropriate) versions on the module. The latest version will be provided if no version number is specified.

### 2.2 Packing of the A5100-A

The A5100-A GPS/GLONASS module comes in a tape and reel package suitable for pick and place machines.

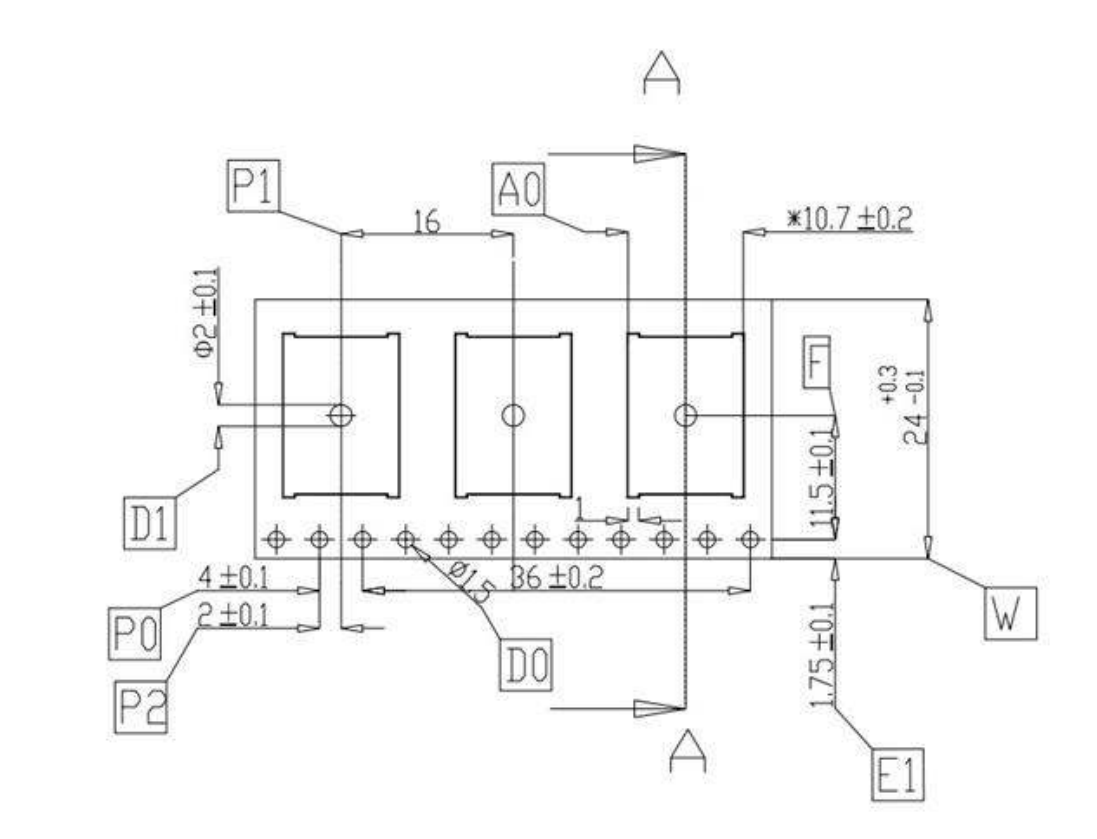

Figure 2: A5100-A tape specifications (1)

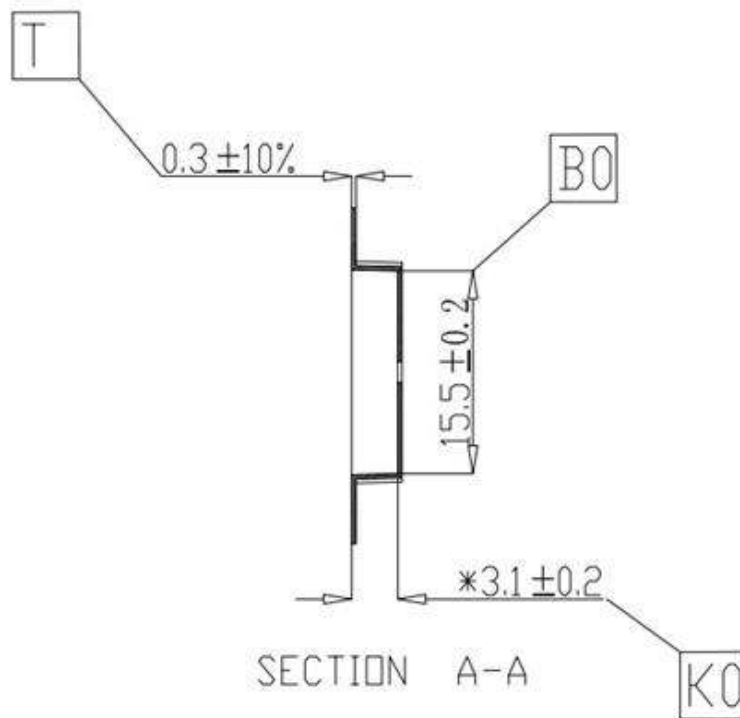

Figure 3: A5100-A tape specifications (2)

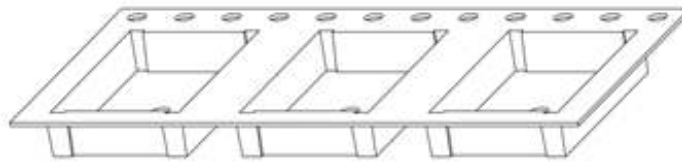

Figure 4: A5100-A tape specifications (3)

One complete reel holds 1300 PCS A5100-A modules.

There are 1 kinds of packaging for shipment:

One box holds 1 reel

Reel diameter: 33 cm

Inner box dimensions: 36(W) x 36(L) x 4.5 (H) cm

Box dimensions: 38.8 (W) x 38.8 (L) x 5.7 (H) cm

Gross weight: 2.58 Kg

Net weight: 0.78 Kg

## 2.3 Additional Equipment

EVA5100-A	Evaluation Kit (including one module A5100-A)
-----------	---

Table 3: Additional equipment

A detailed description of the EVA5100-A Evaluation Kit can be found in the appropriate manual. The evaluation boards are always shipped with latest ROM version and patch loaded.

### 3 Quick Start

In order to allow an easy and quick start with the A5100-A module, this chapter provides a short overview on the important steps to be taken to receive NMEA messages with position information on a serial port (UART).

**NOTE 1:** The A5100-A needs an external pull-up resistor to be configured for UART operation. Please consider the pull-up resistor in your design or pull the GPIO up right after reset by other means.

**NOTE 2:** The ON\_OFF input of the A5100-A needs to be connected to output of a microprocessor. For a wake-up, including the initial one after power on, a LOW-HIGH transmission is mandatory.

#### 3.1 Minimum Configuration

Figure 5 shows the minimum configuration for NMEA outputs and commands sent via an RS232 interface based on the GPS/GLONASS module A5100-A using a passive antenna. It's recommended to supply Vcc continuously for normal operation, the module can enter power saving and hibernation modes by toggling the ON\_OFF pin or sending commands.

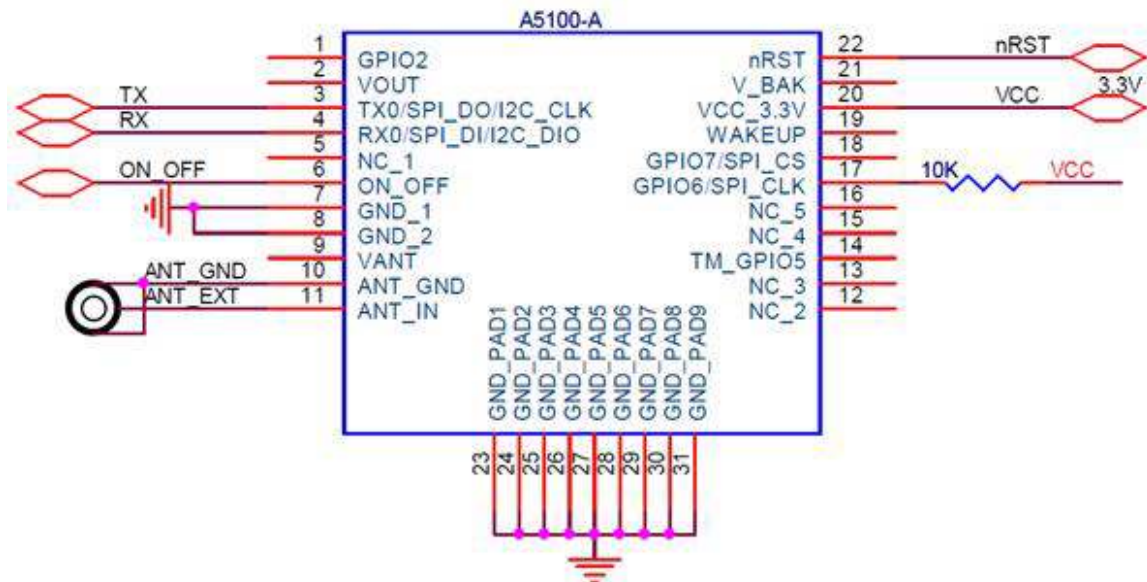

Figure 5: Minimum configuration A5100-A with continued Vcc supply

Remarks:

- External antenna input impedance is 50 Ω. Match as close as possible.
- Supply Vcc continuously, use toggling of ON\_OFF to switch between normal operation and hibernate mode

Figure 6 shows the minimum configuration for NMEA outputs and commands sent via an RS232 interface based on the GPS/GLONASS module A5100-A using a passive antenna and with backup voltage on V\_BAK. Before removing Vcc, it is highly recommended to put A5100-A into hibernation mode either by ON\_OFF pin or software command. Otherwise, high current drain will die out the backup battery in a short period of time.

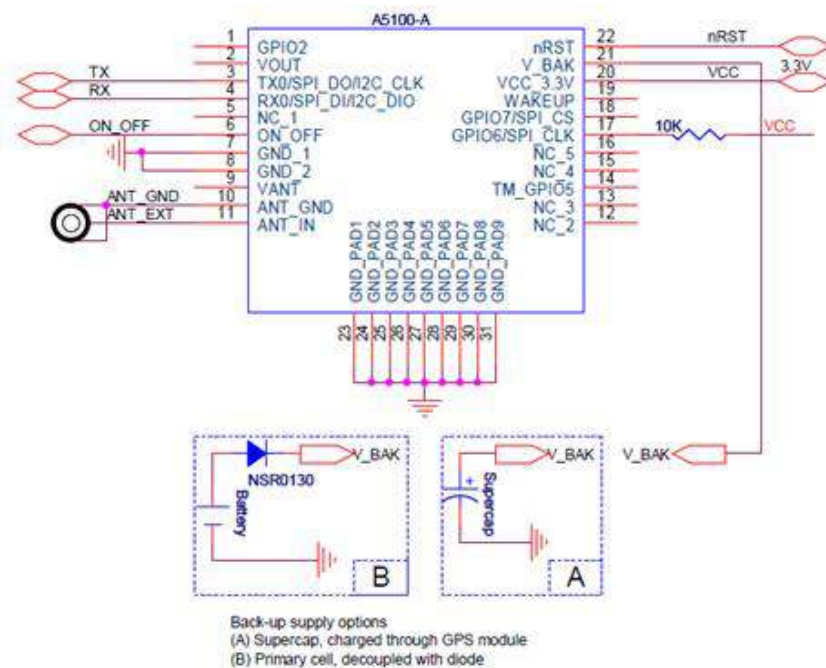

Figure 6: Minimum configuration A5100-A with VBak

#### Remarks:

- External antenna input impedance is 50  $\Omega$ . Match as close as possible.
- A battery back-up circuit for the RTC (Real Time Clock) should be considered (see chapter: **“Error! Reference source not found. Error! Reference source not found.”**)



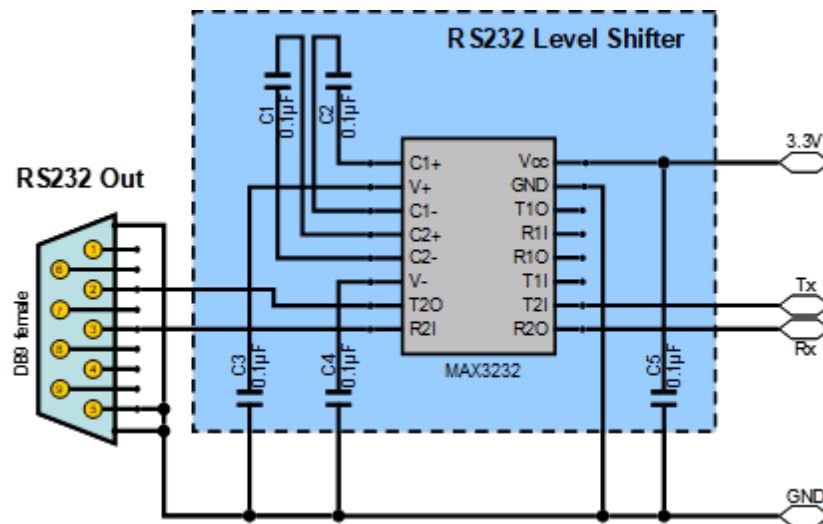

Figure 7: RS232 level shifter

## Remarks:

- Place C1 to C5 (here: 0.1µF) close to MAX3232. For capacity values see datasheet of actual component used.
- Use 3.3V level shifter (MAX3232 or equivalent).
- External antenna input impedance is 50 Ω. Match as close as possible.

## 3.2 Antennas

Generally, the quality of the GPS&GLONASS antenna chosen (passive or active) is of paramount importance for the overall sensitivity of the GPS&GLONASS system. Losses through a bad antenna, long cables or tracks or a bad antenna position can't be compensated afterwards!

### 3.2.1 Passive Antennas

The A5100-A supports passive antennas via an integrated LNA directly.

### 3.2.2 Active Antennas

The A5100-A also supports active antennas directly, i.e. by offering an antenna voltage feed pin (VANT – pin 9). It is recommended to use an active antenna with a supply voltage of 3 to 5 VDC and a maximum current draw of 50 mA. The antenna should have a gain  $\geq 15$ dB but the total gain (antenna gain minus cable loss at the antenna input of the module) should not exceed 30 dB. The noise figure should be  $\leq 1.5$ dB.

### 3.3 Serial Port Settings

In UART operation (defined by the external pull-up resistor as outlined in Minimum Configuration) the default settings are:

- NMEA, 9600 baud, 8 data bits, no parity, 1 stop bit, no flow control

#### 3.3.1 Change Serial Port setting

This command message is used to set the protocol (SiRF binary or NMEA) and/or the communication parameters (Baud rate, data bits, stop bits, and parity). The command is used to switch the module back to SiRF binary protocol mode where a more extensive command message set is available. When a valid message is received, the parameters are stored in battery-backed SRAM and, after a reset, the receiver resumes using the saved parameters.

Table 4 contains the input values for the following example:

Switch to Serial Port Band rate at 4800

Example: \$PSRF100,1,4800,8,1,0\*0E <CR><LF>

Name	Example	Description
MID	\$PSRF100	PSRF100 Protocol header
Protocol	1	0 = SiRF binary 1 = NMEA
Baud	4800	1200, 2400, 4800, 9600, 19200, 38400, 57600, or 115200
DataBits	8	8 only
StopBits	1	1 only
Parity	0	0 = None only
Checksum	*0E	-
<CR><LF>	-	End of message termination

Table 4: Set Serial Port Data Format

### 3.4 Improved TTFF

In order to improve the TTFF (Time To First Fix), it is recommended to keep Vcc supplied or backup battery at V\_BAK at all times so that Navigation data and initial condition (timing and approximate location) are kept current. To reduce power consumption, customers can take advantage of the many sophisticated low power mode features available in the SiRFstarV chipset.

### 3.5 Self-start Configuration

In order to minimize the GPIO required for operating A5100-A, WAKEUP (pin 19) and ON\_OFF (pin 6) can be tied together for entering the self-start mode such that no ON\_OFF pulse requires. The following picture shows the recommended connection for self-start configuration with UART host port enabled.

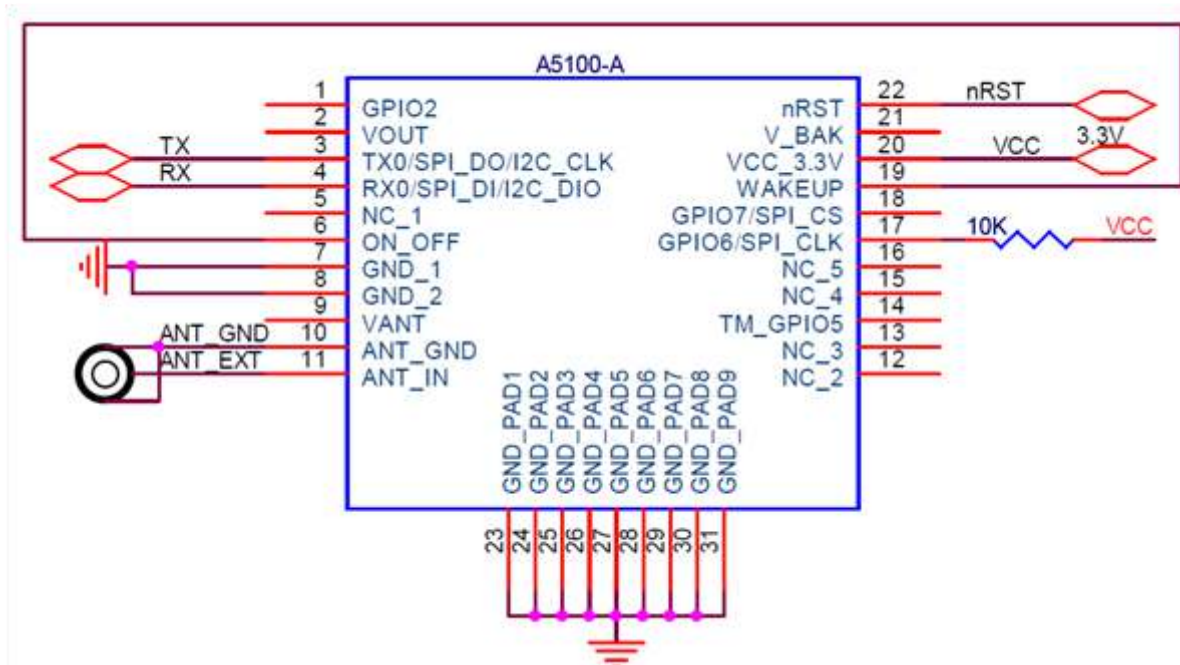

Figure 8: Self-start configuration A5100-A

#### Remarks:

- For self-start mode, full power operation will be activated once Vcc applied. No power save mode (PTF / MPM / TP) will be supported. If customer accidentally configuring A5100-A into hibernation mode, Vcc has to be disconnected and re-plugged so as to operate the module in full power mode.

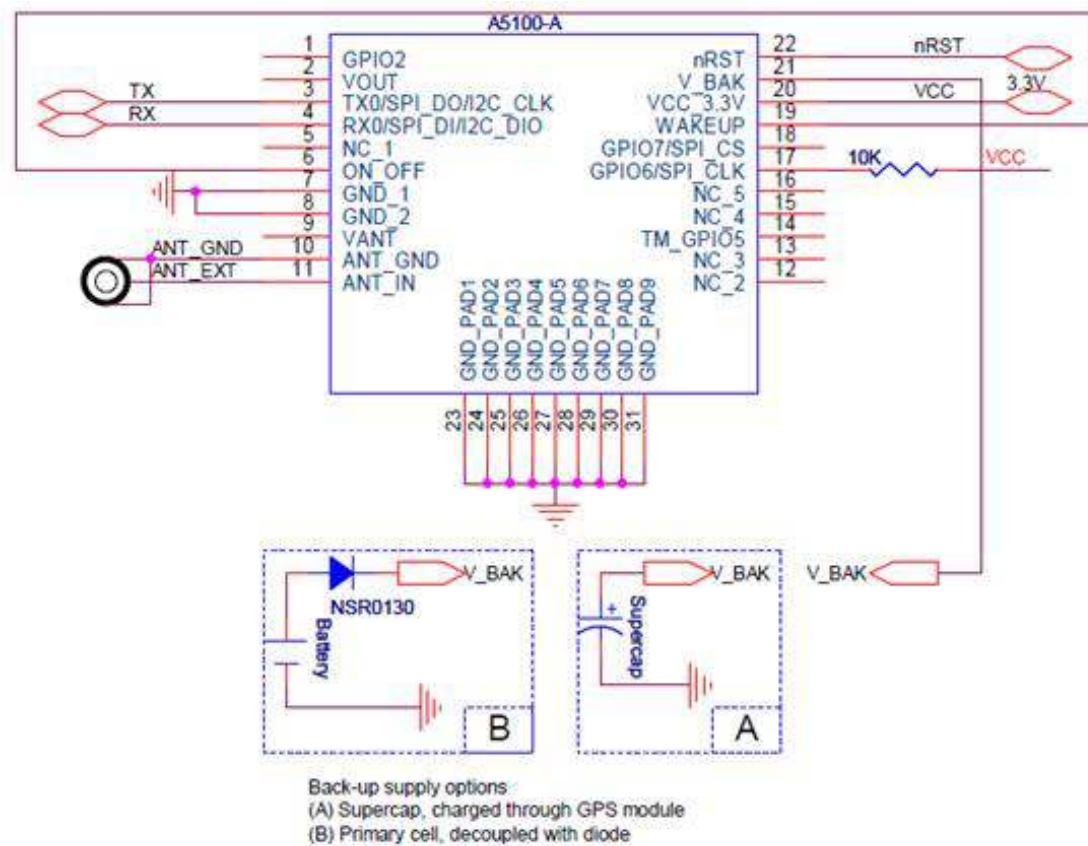

Figure 9: Self-start configuration A5100-A with Vbak

## Remarks:

- External antenna input impedance is 50  $\Omega$ . Match as close as possible.
- A battery back-up circuit for the RTC (Real Time Clock) should be considered (see chapter: **“Error! Reference source not found. Error! Reference source not found.”**)
- For self-start mode, full power operation will be activated once Vcc applied. No power save mode (PTF / MPM / TP) will be supported. Customer can toggle the ON\_OFF pin so as to put the module into hibernation and then remove the Vcc. A5100-A will be self-started again in full power mode when Vcc applied.

## 4 Mechanical Outline

### 4.1 Details Component Side A5100-A

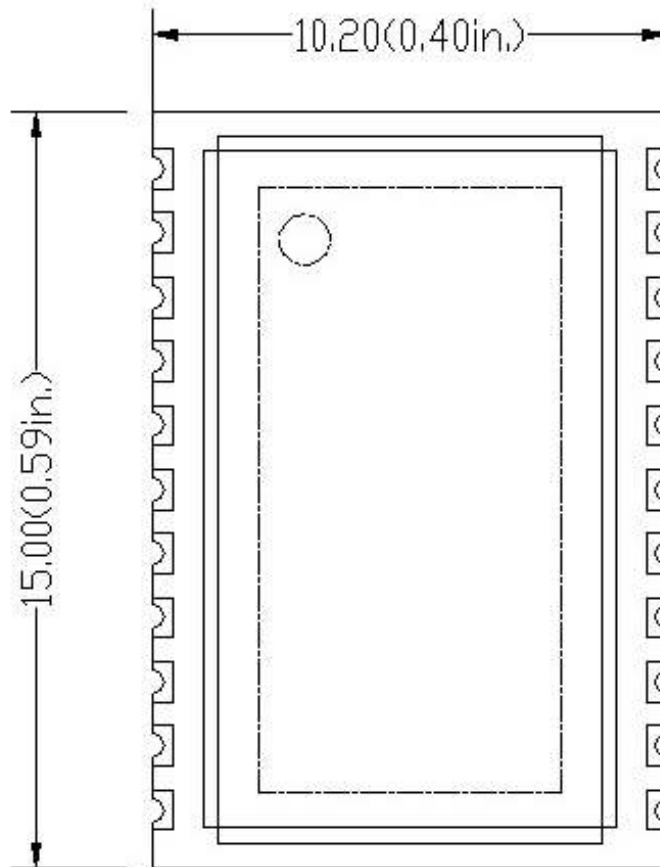

All dimensions in [mm, (inch)]

Figure 10: Mechanical outline component side A5100-A

## 4.2 Details Solder Side A5100-A

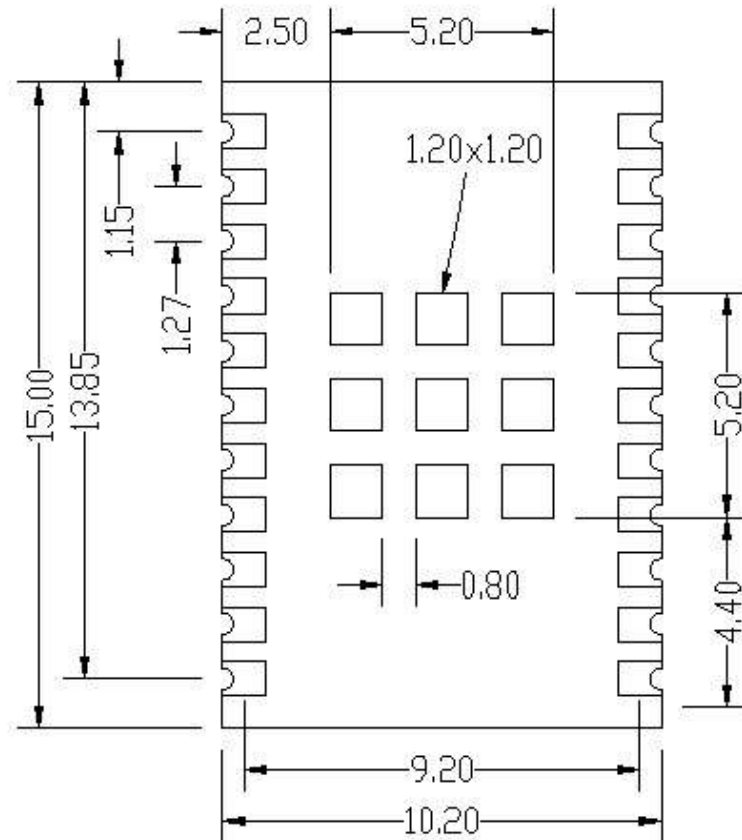

Solder pad size (outer pads): 1.0 x 0.8  
Solder pad size (inner pads): 1.2 x 1.2  
All dimensions in [mm]

Figure 11: Mechanical outline solder side A5100-A

## 5 Pin-out Information

### 5.1 Layout A5100-A

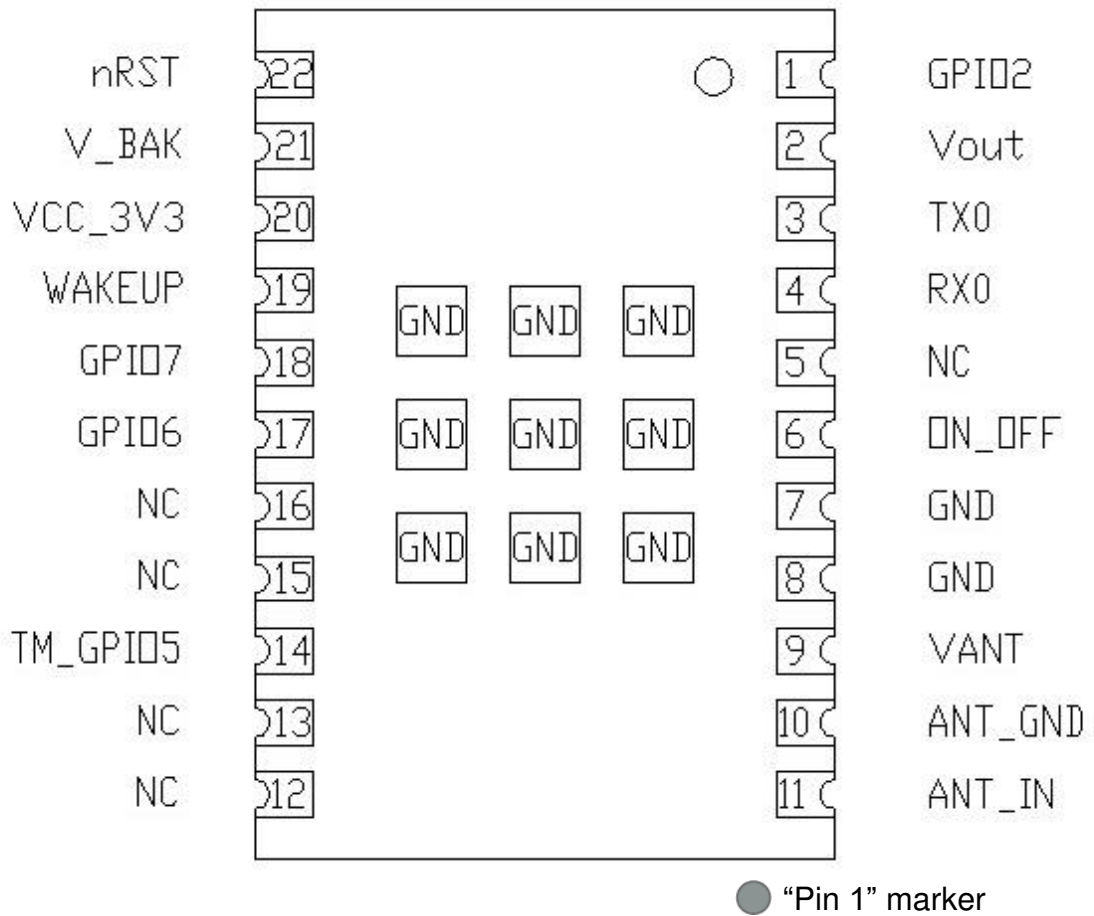

Figure 12: Pin-out information (bottom view) A5100-A

Center Ground pins are for shock / vibration resistance purpose.

## 5.2 Description A5100-A Signals

Pin	Symbol	Function	Description
1	GPIO2	Input/Output	Leave open
2	VOUT	Voltage output	Permanent VCC-0.1 V voltage output for up to 50mA current max
3	TX0/ SPI DO/ I2C CLK	Output	Serial output 0, NMEA out if configured for UART SPI data out pin when module works in SPI mode I2C clock pin when module works in host port I2C mode
4	RX0/ SPI DI/ I2C DIO	Input	Serial input 0, NMEA in if configured for UART SPI data in pin when module works in SPI mode I2C data I/O pin when module works in host port I2C mode.
5	N.C.	None	Leave open
6	ON_OFF	Input	<b>Connect to push-pull output! This is mandatory!</b> - Set to LOW by default - Toggle to HIGH and back to LOW > for first start-up after power on > to request a fix in SiRFaware™ or PTF mode > to go into or wake up out of hibernate mode - Connect it to WAKEUP pin for self-start mode
7	GND	Power Supply	Ground (power supply)
8	GND	Power Supply	Ground (power supply)
9	VANT	Antenna Supply Voltage Input	Power supply input for external active antenna – provide according voltage (up to 5.0 VDC) – switched internally
10	ANT_GND	RF GND	Antenna Ground
11	ANT_IN	Antenna Input	Antenna signal / Z=50 Ohm (antenna input) – must not exceed 30dB gain including cable loss
12	N.C.	None	Leave open
13	N.C.	None	Leave open
14	TM_GPIO5	Output	Time Mark – 1PPS signal
15	N.C.	None	Leave open
16	N.C.	None	Leave open
17	GPIO6/ CTS/ SPI CLK	Input	<b>Configuration pin to run in UART mode (10k pull-up to 3.3V, e.g. to pin 3),</b> Leave open for SPI & host port I2C modes. SPI clock pin when module works in SPI mode
18	GPIO7/ RTS/ SPI CS	Input	Configuration pin for communication mode. 10K to GND for host port I2C mode; leave open for SPI & UART modes. SPI chip select pin when module works in SPI mode
19	WAKEUP	Output	- Status of digital section, Push-Pull output Low = OFF, KA (Keep Alive)-only, Hibernate, or Standby mode High = ON, operational mode - Connect it to ON_OFF pin for self-start mode
20	VCC	Power Supply	3.0 – 3.6 VDC (power supply)
21	V_BAK	Power Supply	Back - up pin of module for “super cap” or battery



22	nRST	Input	Reset input, active low
----	------	-------	-------------------------

Table 5: Pin description A5100-A

## 6 Electrical Characteristics

### 6.1 Operating Conditions

Pin	Description	Min	Typical	Max
21	Vbak	1.8V		3.6V
	Standby Current <sup>(4)</sup>		60uA	
20	V <sub>cc</sub>	3.0V	3.3V	3.6V
	Full power Mode (Searching) Peak Current <sup>(1)</sup>		40mA	
	Full power mode (Searching) Average Current <sup>(2)</sup>		37mA	
	Full power mode (Tracking) Average Current <sup>(3)</sup>		31mA	
	TricklePower Mode		27mA	
	Push-to-Fix Mode		600uA	
	Micro Power Mode (SiRFaware™)		300uA	
	Hibernate Status		60uA	

Table 6: A5100-A electrical characteristics

- (1) Peak searching current is characterized by millisecond bursts above average searching current
- (2) Average searching current is typically only the first two seconds of TTFF
- (3) Tracking current typically includes tracking and the post searching portion of TTFF
- (4) During standby state: RTC block and core powered on and clock off.

## 6.2 Absolute Maximum Ratings

Symbol	Parameter	Min	Max	Unit
Vcc	A5100-A Power supply	-0.3	+3.6	V
Vin	Voltage to I/O pins	-0.3	+3.6	V
Iov	Input current on I/O pins	-10	10	mA
Itdv	Absolute sum of all input currents during overload condition		200	mA
Tst	Storage temperature	-40	85	°C
Vant	Antenna supply voltage	0	5.5	V
Iant	Antenna supply current	0	50	mA

Table 7: Absolute maximum ratings

Stresses beyond those listed under “Absolute Maximum Ratings” may cause permanent damage to the device. This is a stress rating only. Functional operation of the device at these or any other conditions beyond those indicated in the operational sections of this specification is not implied. Exposure to absolute maximum rating conditions for extended periods may affect device reliability.

### 6.3 DC Electrical Characteristics

Symbol	Parameter	Min	Max	Unit
TX0, WAKEUP	Voh @ 4mA	2.6	Vcc	V
	Vol @ 4mA		0.45	V
RX0	Vih	2.0	Vcc	V
	Vil		0.8	V
nRST	for safe reset		0.2	V
ON_OFF	Vih	1.35	Vcc	V
	Vil	-0.3	0.45	V

Table 8: DC electrical characteristic A5100-A

## 7 Mounting

This chapter describes the suggested mounting process for the A5100-A receiver modules. In a RoHS compliant product with a RoHS compliant process it is recommended to use chemical tin as the counter-part to the module's pins. This will guarantee highest resistance against shocks.

### 7.1 Proposed Footprint for Soldering

Following soldering footprint parameters are recommended:

- Copper and solder paste footprint are identical
- Pad-shape / -size, inner pads: 1.2 mm x 1.2 mm
- Pad-shape / -size, outer pads: 1.5 mm x 0.8 mm
- Stencil thickness of 120 – 150  $\mu\text{m}$

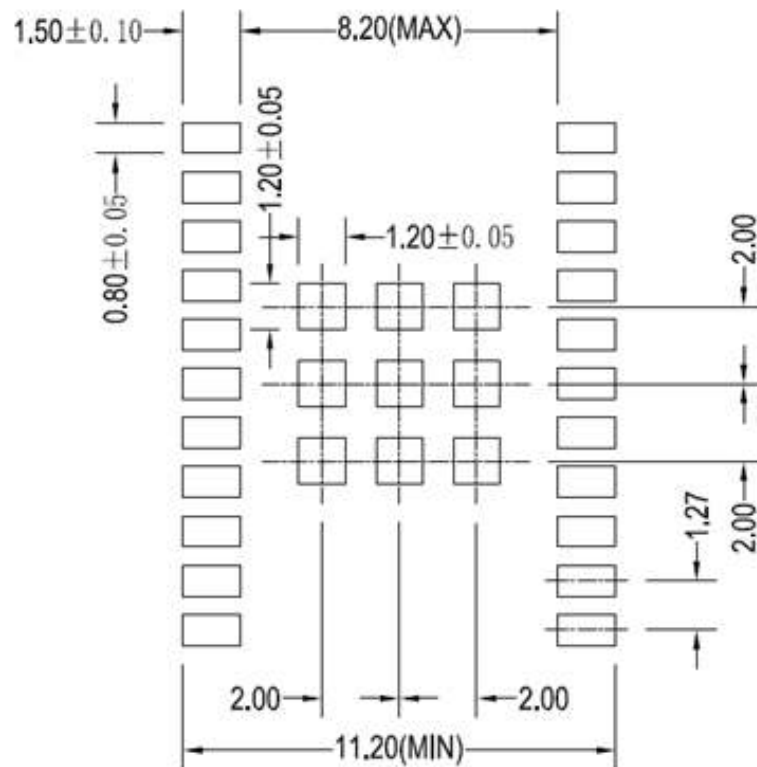

Figure 13: Recommended Solder PAD Layout

## 7.2 Recommended Profile for Reflow Soldering

Typical values for reflow soldering of the module in convection or IR/convection ovens are as follows (according to IPC/JEDEC J-STD-020D):

Parameter	Value
Peak temperature (RoHS compliant process)	245°C
Average ramp up rate to peak (217°C to Peak)	3°C / second max.
Preheat temperature	min=150°C; max=200°C
Ramp up time from min. to max. preheat temperature	60 ... 120 seconds
Temperature maintained above 217°C	60 ... 150 seconds
Time within 5°C of actual peak temperature	30 seconds
Ramp down rate	6°C / second max.
Time 25°C to peak temperature	8 minutes max.

Table 9: Reflow soldering profile A5100-A

The solder pads hold solder of a thickness of about 150 µm for improved solder process results.

As results of soldering may vary among different soldering systems and types of solder and depend on additional factors like density and types of components on board, the values above should be considered as a starting point for further optimization.

## 8 Use of GPS & GLONASS Antennas

### 8.1 Connecting a GPS & GLONASS antenna to the GPS & GLONASS receiver

The ANT pin is used to connect a GPS&GLONASS antenna to the receiver. The design of the antenna connection has to be done strictly according to RF design rules. A  $50\ \Omega$  PCB strip line is required. The following drawings shall explain the guidelines. A major rule is to keep the strip line as short as possible. Additionally, antenna ground (ANT\_GND) should be routed to the ground plane of the PCB (the ground plane is on a lower PCB layer) by vias as demonstrated in the drawing.

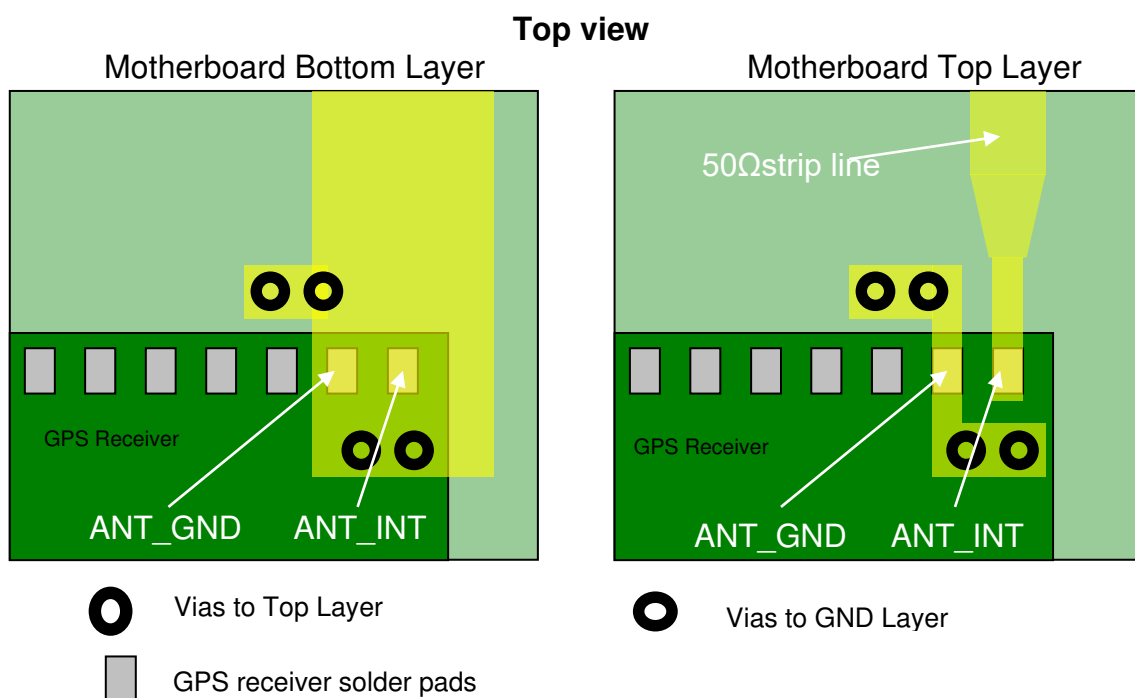

Figure 14: Antenna connector strip line A5100-A

In order to achieve the impedance of  $50\ \Omega$ , the width of the strip line needs to be calculated. It depends on the thickness or height of the PCB layer (both parameters are shown in following drawing). For the calculation, it is assumed that the PCB material is FR4.

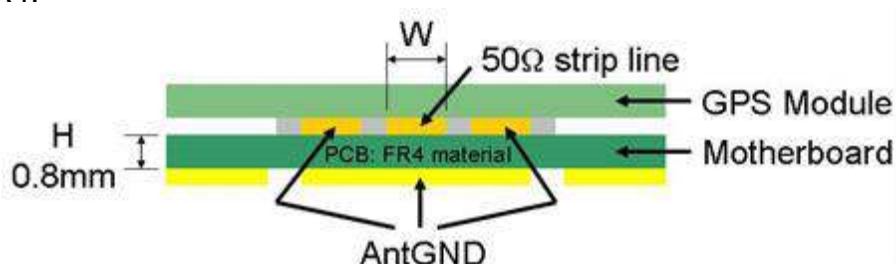

Figure 15: Strip line parameters A5100-A

In this case, the width should be about 1.8 times the height of the PCB:

$$W = 1.8 \times H$$

In the example, one would get a width of  $W = 1.8 \times 0.8 \text{ mm} = 1.44 \text{ mm}$ .



## 8.2 Antenna Connections

### 8.2.1 Passive Antennas

A passive antenna connected to ANT input (pin 11) should be placed as close as possible to the GPS&GLONASS receiver. The signal power lost by the antenna cable or lost by the strip line on the PCB cannot be recovered by the LNA (Low Noise Amplifier) integrated in the GPS&GLONASS receiver.

A suitable Ground-Plane design should be considered depending on the antenna type connected to ANT input (pin 11).

### 8.2.2 Active Antennas

General GPS&GLONASS active antenna specification:

Limitations:

- Supply voltage (voltage fed into VANT pin) 5V (max.)
- Supply current 50mA (max.)

Recommendations:

- Gain  $\geq 15\text{dB}$  (should not exceed 30 dB including cable loss)
- Noise figure  $\leq 1.5\text{dB}$

The recommendations apply to the majority of active antennas that can be found in the market. Anyhow, the quality of the GPS&GLONASS antenna chosen is of paramount importance for the overall sensitivity of the GPS&GLONASS system.

The system design needs to reflect the supply voltage of the antenna. If the supply voltage is equal to  $V_{cc}$ ,  $V_{cc}$  can be connected to VANT. If the antenna requires a different supply voltage, the antenna bias can be provided through the VANT pin.

VANT is switched by the module, so current is only drawn when required.

## 9 Quality and Reliability

### 9.1 Environmental Conditions

Operating temperature	-40 ... +85°C
Operating humidity	Max. 85% r. H., non-condensing, at 85°C
MSL JEDEC (Moisture Sensitivity Level)	3
Storage	6 months in original package.

Table 10: Environmental conditions

### 9.2 Product Qualification

Prior to product qualification the GPS&GLONASS receiver is preconditioned according to EIA/JEDEC standard JESD22-A113-B / Level 3.

Basic qualification tests:

- MSL Classification according to J-STD-020C (MSL3 @ 245°C)
- MSL Rework Compatibility according to J-STD-020C
- Temperature Cycling –40°C ... +85°C
- Temperature Humidity Bias 70°C / 85% RH
- Low / High Temperature Operating –40°C / +85°C
- High Temperature Operating Life +85°C
- Vibration Variable Frequency
- Mechanical Shock

Please contact Lantronix for detailed information.

### 9.3 Production Test

Each module is electrically tested prior to packing and shipping to ensure state of the art GPS&GLONASS receiver performance and accuracy.

## 10 Applications and Hints

### 10.1 Initial Module Start

After initially applying power to the module, it is necessary to start the internal firmware by toggling the ON\_OFF pin. Toggling is done by pulling the signal to HIGH for about 200ms. This first toggling can be done after a LOW – HIGH transmission was detected at the WAKEUP pin or by simply waiting for 1s after power-up. In case of configuration for UART mode, messages should be transmitted afterwards. If no messages should appear, a new toggling should be applied.

### 10.2 Proper Shutdown

A controlled and orderly shutdown while the A5100-A is running in full power mode can be initiated by

- A 200ms pulse on the ON\_OFF pin,
- According messages either in NMEA or OSP mode.

The shutdown is completed after maximum 1s. Therefore the module should be supplied with voltage for that time after the shutdown sequence was initiated.

### 10.3 SiRFaware™ Support

SiRFaware™ is a low-power operating mode that seeks to maintain low uncertainty in position, time, and frequency, and to maintain valid current Ephemeris using either data collected from satellites in view or Extended Ephemeris methods.

The SiRFaware™ mode is entered using the One Socket Protocol, an extension of the SiRF Binary Protocol. Please refer to the appropriate manual. In order to request a fix and to exit SiRFaware™ it is necessary to toggle the ON\_OFF pin. Toggling is done by pulling the signal to HIGH for about 200ms.

### 10.4 Push-to-Fix Mode

Push-to-Fix mode is designed for the application that requires infrequent position reporting. The receiver generally stays in a low-power mode, up to 2 hours, but wakes up periodically to refresh position, time, ephemeris data and RTC calibration.

The push-to-fix mode is initialized and entered using the SiRF Binary Protocol. Please refer to the appropriate manual, paying particular attention to the paragraph titled “Set TricklePower Parameters”. In order to request a fix outside the specified duty cycles, it is necessary to toggle the ON\_OFF pin. Toggling is done by pulling the signal to HIGH for about 200ms.

### 10.5 Hibernate Mode

In order to enter Hibernate Mode it is necessary to send a shutdown command or to toggle to ON\_OFF pin by pulling the signal to HIGH for about 200ms. Starting with ROM2.1 the according command is supported in NMEA and SiRF Binary mode. After

a short delay the module will switch into hibernate mode. The RTC will keep on running and SRAM is backed with the typical current of 20  $\mu$ A drawn from Vcc. To wake the module up again, toggling the ON\_OFF pin is necessary (200ms pulse width).

## 10.6 Battery Back-up

This section describes how to back-up the RTC and the SRAM of the GPS receiver module. The basics of the first example addresses providing a back-up power supply by using a separate battery or a “Super cap”.

While the “Super cap” is charged through the module during normal operation, the battery (primary cell) is decoupled thru a diode!

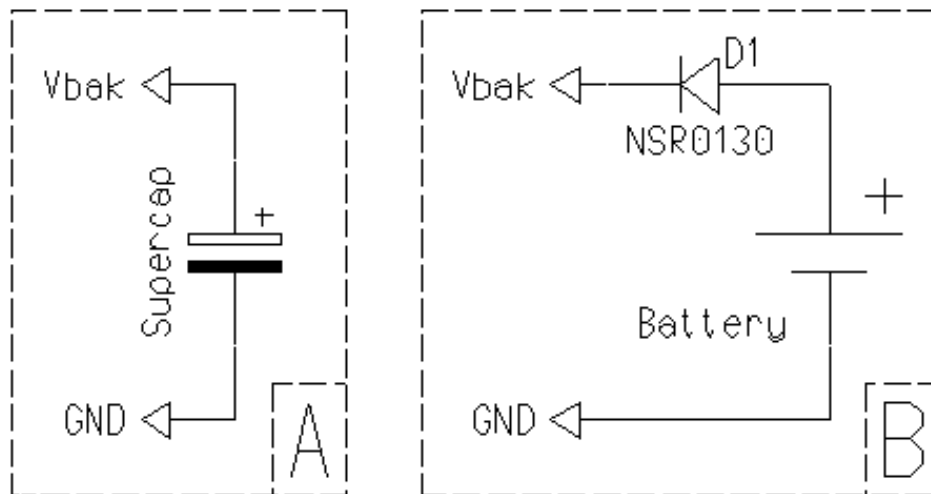

Backup Supply Options

(A) Supercap, charged through GPS module

(B) Primary cell, decoupled with diode

Figure 16: Strip line parameters A5100-A

An alternative to this solution is to switch the supply voltage from the Vcc pin to the Vbak pin. Care needs to be taken that there is no voltage outage during the switch-over phase!

## 10.7 Extended Ephemeris

The receiver is capable of supporting two versions of using Extended Ephemeris (EE) data. The first one is the version, where the EE data are calculated on a server, are transmitted to device incorporating the receiver, and are then loaded into the receiver. These data can be valid for up to seven days.

The second version is the internal extrapolation of available “natural” Ephemeris data. This is done automatically and no external support is required. The internally calculated EE data are valid for up to 3 days.

The receiver firmware will define which set of EE data to use or will neglect those in case “natural” data are available. Both versions of EE data will help to further lower power consumption in SiRFaware™ mode.

## 10.8 Antenna Status Adaptation

This chapter shall give assistance in designing a circuit for detecting if an active antenna is connected to the module. The information about the antenna status can be derived from the ANTSTAT signal generated by this circuit. The examples use values for components that roughly result in the following ANTSTAT output:

- Logic low when:  $I_{ant} < 9\text{mA}$
- Logic high when:  $9\text{mA} > I_{ant} < 16\text{mA}$
- Logic low when:  $I_{ant} > 16\text{mA}$

### 10.8.1 Antenna Sensor

The following circuit is a proposal on how you can feed an antenna with 3.3V and provide an output for the ANTSTAT pin. The value of the components may need an adaptation in the final application. For example, the input current of the chosen comparator goes into that equation. The thresholds defined in this circuit are quite close to the ones described above. Their value is determined by resistors R4, R5, and R3.

We strongly recommend simulating and testing the GPS&GLONASS receiver integrated in your product design before implementing the finalized product in the appropriate market application.

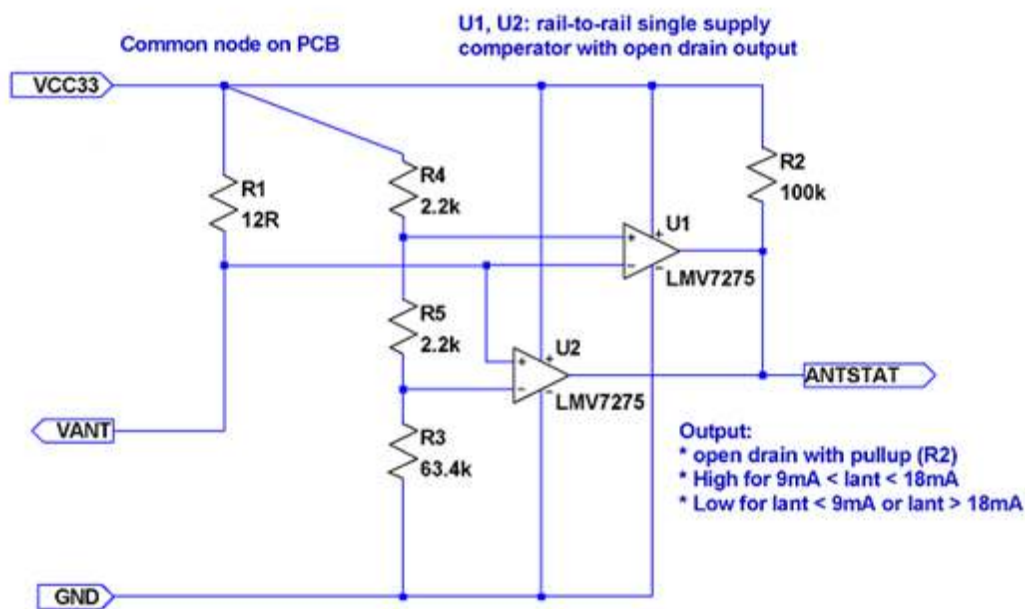

Figure 17: Application note: Antenna sensor adaptation

### 10.8.2 Antenna Sensor with Current Limiter

This proposal is similar to the first one, but includes a current limiter. Comments and notes as above apply.

We strongly recommend simulating and testing the GPS&GLONASS receiver integrated in your product design before implementing the finalized product in the appropriate market application. In any case it is the responsibility of the designer to test and verify the implementation.

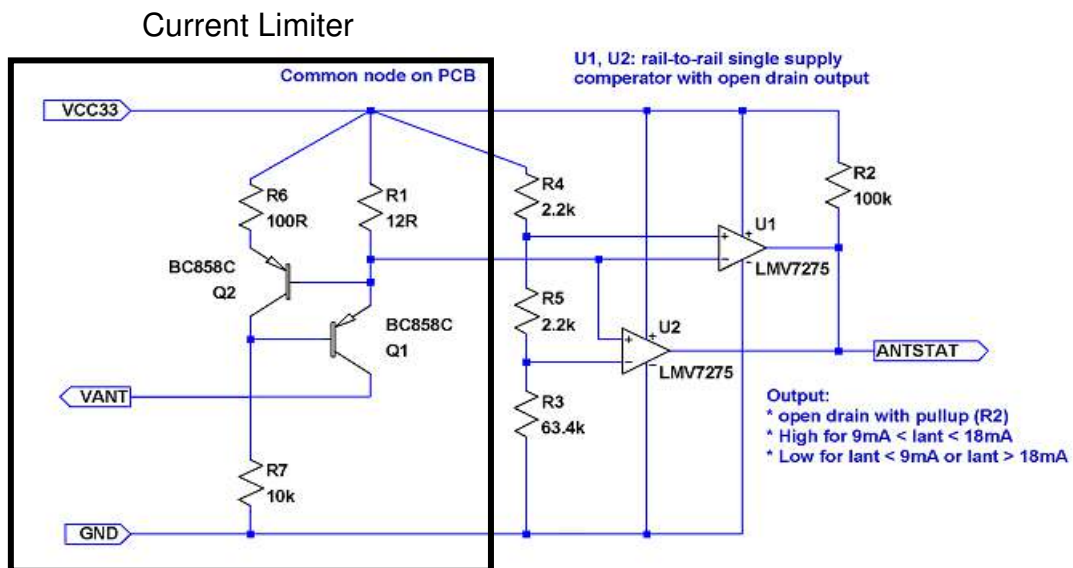

Figure 18: Application note: Antenna sensor adaptation with current limiter



## 10.9 VANT Pin

The VANT pin is an input pin.

The supply voltage for an active GPS&GLONASS antenna on the ANT input has to be fed into the Vant pin. The easiest way to do that is to connect Vcc to VANT. The maximum current is 50 mA.

**Note:** Shortcut between ANT and GND may damage the A5100-A GPS&GLONASS receiver module. This should be avoided by using an antenna current limiter.

The circuit (chapter “0

Antenna Sensor with Current Limiter”) works for Vcc from 3V to 5V. The antenna current will be limited to 50 mA approximately.

If other transistors are used, other resistor values may be necessary as well. We strongly recommend simulating and testing your realized version before using it.

### **10.10 TM\_GPIO5 pin (1 pulse per second pin)**

The 1PPS pin is an output pin.

In addition to precise positioning, GPS&GLONASS also allows for accurate timing due to the synchronized atomic clocks in the GPS&GLONASS satellites. While the current date and time is transmitted in NMEA sentences (UTC), an exact and accurate timing signal is provided via the 1PPS pin of the A5100 GPS&GLONASS receiver.

Under good signal conditions the 1PPS signal comes between 620ns and 710ns after the full GPS&GLONASS system second which is accurately (around 10ns) synchronized to UTC. Therefore the 1 second clock can be derived and maintained within around 90ns under good signal conditions.

Note:

The 1PPS clock accuracy directly depends on the position accuracy!

The GPS&GLONASS signals travel at the speed of light, therefore a position inaccuracy directly translates into 1PPS inaccuracies.

10m position deviation  $\approx$  33ns 1PPS deviation (typically)

100m position deviation  $\approx$  333ns 1PPS deviation (typically)

The NMEA messages containing absolute timing information (UTC time) are provided around 300ms after the 1PPS signal typically. This may change with the GPS&GLONASS receiver setup.

The 1PPS signal is provided on a “as is” basis with no accuracy specification. It's NOT recommended to use 1PPS signal for accurate timing application.

The given values are based on a 10 satellite, static GPS&GLONASS simulator scenario.

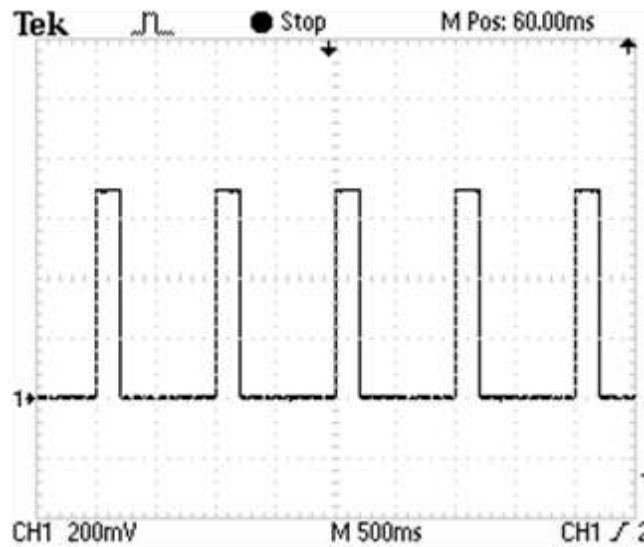

Figure 19: 1PPS waveform (reference)

### 10.11 5 Hz Navigation Update Rate

User can select 1Hz or 5Hz output rate of navigation computation and message, it supports rapid change of direction and improves accuracy on sport-related applications. 1Hz is the default Navigation Update Rate, If the user want to change to 5Hz Navigation Update Rate, Please refer to command below:

Enable 5Hz Navigation Update Rate command

- NMEA command MID103 (\$PSRF103,00,6,00,0\*23)
- OSP command MID136 (A0 A2 00 0E 88 00 00 04 04 00 00 00 00 00 00 00 0F 02 00 A1 B0 B3 )

Disable 5Hz and return to 1Hz Navigation Update Rate, command:

- NMEA command MID103 (\$PSRF103,00,7,00,0\*22)
- OSP command MID136 (A0 A2 00 0E 88 00 00 04 00 00 00 00 00 00 00 00 0F 02 00 9D B0 B3)

## 11 Evaluation Kit EVA5100-A

For demonstration and easy evaluation of GPS&GLONASS performance Lantronix offers an evaluation kit (including one GPS&GLONASS A5100-A module). It contains a USB interface with according drivers to connect easily to a PC. The USB interface is an extension of the serial port 0, therefore sending NMEA sentences or binary information and accepting commands. At the same time it provides power to the module. Accompanied by both an active and passive antenna it offers a ready-to-go set.

For the development of new software and applications the Evaluation Kit also provides NMEA and binary messages on CMOS level via a terminal plug.

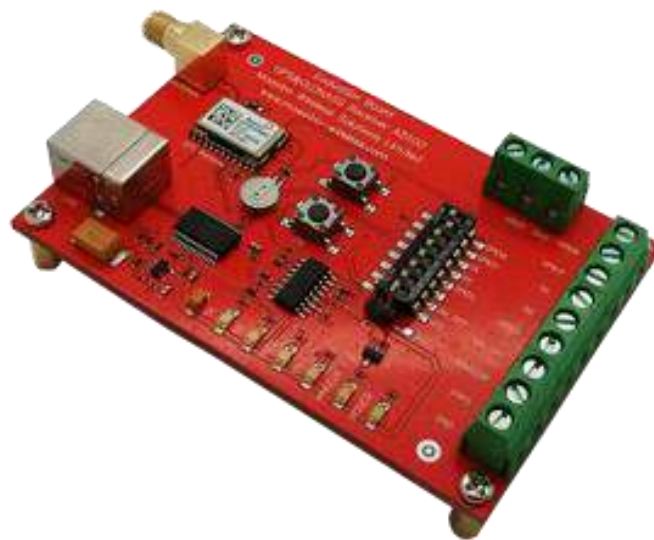

Figure 20: Evaluation kit EVA5100-A

For further information please contact Lantronix.

## **12 Related Information**

### **12.1 Related Documents**

- GPS Evaluation Kit EVA5100-A (Lantronix)
- SSV NMEA Reference Guide (SiRF)
- One Socket Protocol Interface Control Document (SiRF)

### **12.2 Related Tools**

- GPS Cockpit (Lantronix)
- SiRFLive (SiRF)