

Features:

- 0603/1608 foot print
- Ideal ESD protection for high frequency, low voltage applications.
- Exceeds testing requirements outlined in IEC 61000-4-2
- Ultra low capacitance (0.15pF maximum)
- Very low leakage current
- Fast response time
- Bi-directional
- Surface mount

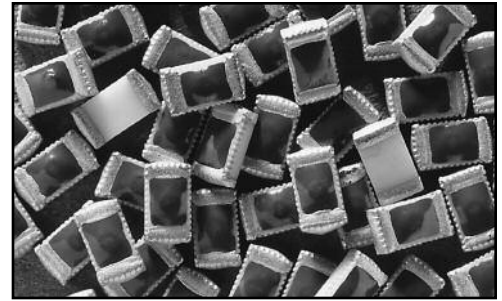

Applications

- | | | |
|---|---|--|
| <ul style="list-style-type: none"> • Computers & Peripherals • HDTV Equipment • DVD Players • A/V Equipment • Satellite Radio • Cell Phones | <ul style="list-style-type: none"> • PDA's • Digital Still Cameras • Digital Camcorders • MP3 / Multimedia Players • Set Top Boxes • External Storage • DSL Modems | <ul style="list-style-type: none"> • High Speed Data Ports <ul style="list-style-type: none"> • USB 2.0 • IEEE 1394 • HDMI • DVI • High Speed Ethernet • Infiniband® |
|---|---|--|

Description

The PolySURG™ 0603ESDA-TR ESD Suppressors protect valuable high-speed data circuits from ESD damage without distorting data signals as a result of its ultra-low (0.15pF maximum) capacitance.

Ordering Information

Catalog Number	Packaging
0603ESDA-TR1	5,000 pieces in paper tape on 7" (178mm) reel

Part Ratings and Characteristics:

Performance Characteristics	Units	Min	Typ	Max
Continuous operating voltage	VDC	-	-	24
Clamping voltage ²	V	-	35	60
Trigger voltage ³	V	-	125	-
ESD Threat voltage capability ⁴	kV	-	8	15
Capacitance (@ 1 KHz ~ 1.8GHz)	pF	-	-	0.15
Leakage current (@ 12 VDC)	nA	0.01	<0.1	-
Peak current ²	A	-	30	45
Operating temperature	°C	-56	+25	+105
ESD pulse withstand ²	# pulses	20	>500 ¹	-

Notes:

1. Some shifting in characteristics may occur when tested over several hundred ESD pulses at very rapid rate of 1 pulse per second or faster.
2. Per IEC 61000-4-2, 30A @ 8kV, level 4, clamp measurement made 30ns after initiation of pulse, all tests in contact discharge mode.
3. Trigger measurement made using Transmission Line Pulse (TLP) method
4. PolySURG™ devices are capable of withstanding up to a 15 kV, 45A ESD pulse. Device ratings are given at 8kV per Note 1, unless otherwise specified.

Product Dimension

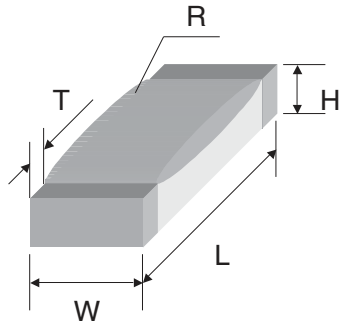

EIA Size mm (in)	L	W	H	T	R
0603ESDA	1.60 ± 0.10 (.063 ± .004)	0.80 ± 0.10 (.031 ± .004)	0.50 ± 0.10 (.020 ± .004)	0.30 ± 0.20 (.012 ± .008)	0.70 ± 0.10 (.028 ± .004)

Recommended Solder Pad Outline
(per IPC-SM-782)

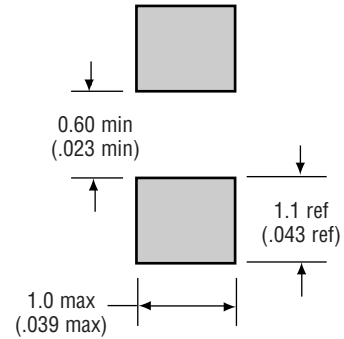

Tape-and-Reel Specification

Dimension	0603
A	1.90±0.20 (.075±0.008)
B	1.10±0.20 (.043±0.008)

Environmental Specifications:

- Moisture Resistance per EIA/IS-722 Paragraph 4.4.2. This standard is based upon MIL-STD-202G Method 103B but with temperature and relative humidity at +85°C and 85% RH respectively. Test condition 'A' (240Hr) per MIL-STD-202G
- Thermal shock: MIL-STD-202, Method 107G, -55°C to 125°C, 30 min. cycle, 10 cycles
- Vibration: MIL-STD-202F, Method 201A, (10 to 55 to 10 Hz, 1 min. cycle, 2 hrs each in X-Y-Z)
- Chemical resistance: ASTM D-543, 4 hrs @ 40°C, 3 solutions (H₂O, detergent solution, defluxer)
- Operating temperature characteristics, measurement at +25°C, +105°C and -56°C
- Full load voltage: 14.4VDC, 18VDC & 24VDC for 1000 hrs, 25°C
- Solder leach resistance and terminal adhesion: Per EIA-576
- Solderability: MIL-STD-202, Method 208 (95% coverage)

Device Marking

ESDA devices are marked on the tape and reel packages, not individually. Since the product is bi-directional and symmetrical, no orientation marking is required.

Design Consideration

The location in the circuit for the TR series has to be carefully determined. For better performance, the device should be placed as close to the signal input as possible and ahead of any other component. Due to the high current associated with an ESD event, it is recommended to use a "0-stub" pad design (pad directly on the signal/data line and second pad directly on common ground).

Processing Recommendations

The TR series currently has a convex profile on the top surface of the part. This profile is a result of the construction of the device. They can be processed using standard pick-and-place equipment. The placement and processing techniques for these devices are similar to those used for chip resistors and chip capacitors.

Soldering Recommendations

- Compatible with lead and lead-free solder reflow processes
- Peak reflow temperatures and durations:
 - IR Reflow = 260°C max for 10 sec. max.
 - Wave Solder = 260°C max. for 10 sec. max.
- Recommended IR Reflow Profile:

