

NS-208G/NS-208AG

NSM-208G/NSM-208AG

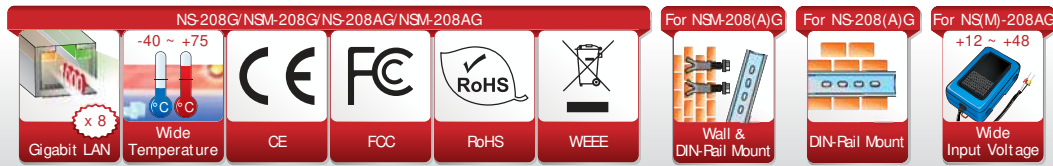

Features ▶▶▶

- Automatic MDI/MDI-X crossover for plug-and-play
- Store-and-forward architecture
- Full duplex IEEE 802.3x and half duplex backpressure flow control
- Supports +12 V_{DC} ~ +48 V_{DC} power input for NS-208AG and NSM-208AG
- Each port supports 10/100 and 1000 Mbps speed auto negotiation
- 16 Gbps high performance memory bandwidth
- Supports 9K Jumbo Frames for Speed 1000M
- Supports operating temperatures from -40 °C ~ +75 °C
- DIN-Rail Mounting

Introduction

The NS-208G/NSM-208G has 8 Ethernet Switching ports that support 10/100/1000 Base-T, with a 10/100/1000M auto negotiation feature and auto MDI/MDI-X function. It can connect 8 workstations and automatically switches the transmission speed (10 Mbps or 100 Mbps or 1000 Mbps) for corresponding connections.

The flow control mechanism is also negotiated. There is link/data rate LEDs for each port to aid troubleshooting. Port connectors are shielded RJ-45.

NS-208AG/NSM-208AG is exactly the same as NS-208G/NSM-208G except for the power input.

Specifications

Models	NS-208G	NS-208AG	NSM-208G	NSM-208AG
Technology				
Standards	IEEE 802.3, 802.3u, 802.3ab and 802.3x			
Processing Type	Store & forward; wire speed switching			
MAC Addresses	8192			
Memory Bandwidth	16 Gbps			
Frame Buffer Memory	1 Mbit			
Jumbo Frames	9K for Speed 1000M			
Flow Control	IEEE 802.3x flow control, back pressure flow control			

Models	NS-208G	NS-208AG	NSM-208G	NSM-208AG
Interface				
RJ-45 Ports	10/100 Base-T(X) auto negotiation speed, F/H duplex mode, and auto MDI/MDI-X connection			
LED Indicators	Power, 10/100/1000M, Link/Act			
Ethernet Isolation	1500 V _{rms} 1 minute			
EMS Protection	Yes			
Cable	Ethernet	2-pair UTP/STP Cat.3, 4, 5, EIA/TIA-568 100 Ω		
	Fast Ethernet	2-pair UTP/STP Cat. 5, EIA/TIA-568 100 Ω		
	Gigabit Ethernet	4-pair UTP/STP Cat.5, EIA/TIA-568 100 Ω		
Power Input				
Input Voltage Range	+10 V _{dc} ~ +30 V _{dc}	+12 V _{dc} ~ +48 V _{dc}	+10 V _{dc} ~ +30 V _{dc}	+12 V _{dc} ~ +48 V _{dc}
Power Consumption	0.3 A @ 24 V _{dc}			
Protection	Power reverse polarity protection			
EMS Protection	Yes			
Connector	5-Pin Removable Terminal Block			
Mechanical				
Casing	Plastic (Flammability UL 94V-0)		Metal (IP20 Protection)	
Dimensions (W x L x H)	64 mm x 98 mm x 119 mm		73 mm x 102 mm x 132 mm	
Installation	DIN-Rail Mounting		DIN-Rail Mounting or Wall Mounting	
Environment				
Operating Temperature	-40 °C ~ +75 °C			
Storage Temperature	-40 °C ~ +75 °C			
Ambient Relative Humidity	10% ~ 90% RH, non-condensing			

Dimensions (Units: mm)

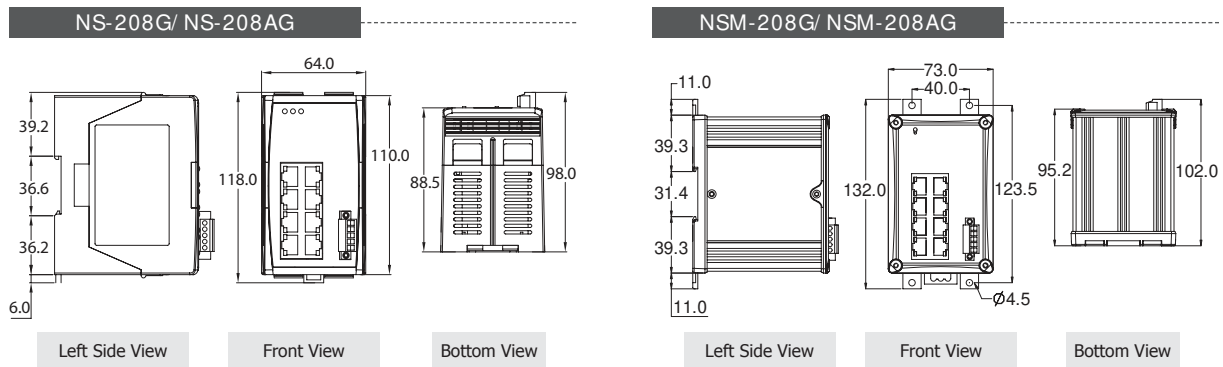

Ordering Information

NS-208G CR	Unmanaged 8-port 10/100/1000 Base-T Ethernet Switch with Power Input +10 V _{dc} ~ +30 V _{dc} (RoHS)
NSM-208G CR	Unmanaged 8-port 10/100/1000 Base-T Ethernet Switch with Power Input +10 V _{dc} ~ +30 V _{dc} , metal casing (RoHS)
NS-208AG CR	Unmanaged 8-port 10/100/1000 Base-T Ethernet Switch with Power Input +12 V _{dc} ~ +48 V _{dc} (RoHS)
NSM-208AG CR	Unmanaged 8-port 10/100/1000 Base-T Ethernet Switch with Power Input +12 V _{dc} ~ +48 V _{dc} , metal casing (RoHS)

Accessories

DIN-KA52F	24 V/1.04 A, 25 W Power Supply with DIN-Rail Mounting
DIN-KA52F-48	48 V/0.52 A, 25 W Power Supply with DIN-Rail Mounting
KA52F-48	48 V/0.52 A, 25 W Power Supply without DIN-Rail Mounting
MDR-20-24	24 V/1 A, 24 W Power Supply with DIN-Rail Mounting
MDR-60-48	48 V/1.25 A, 60 W Power Supply with DIN-Rail Mounting