

REVISIONS					
P	LTR	DESCRIPTION	DATE	DWN	APVD
F2		REVISED PER ECR-22-160893	15DEC2022	DB	BW

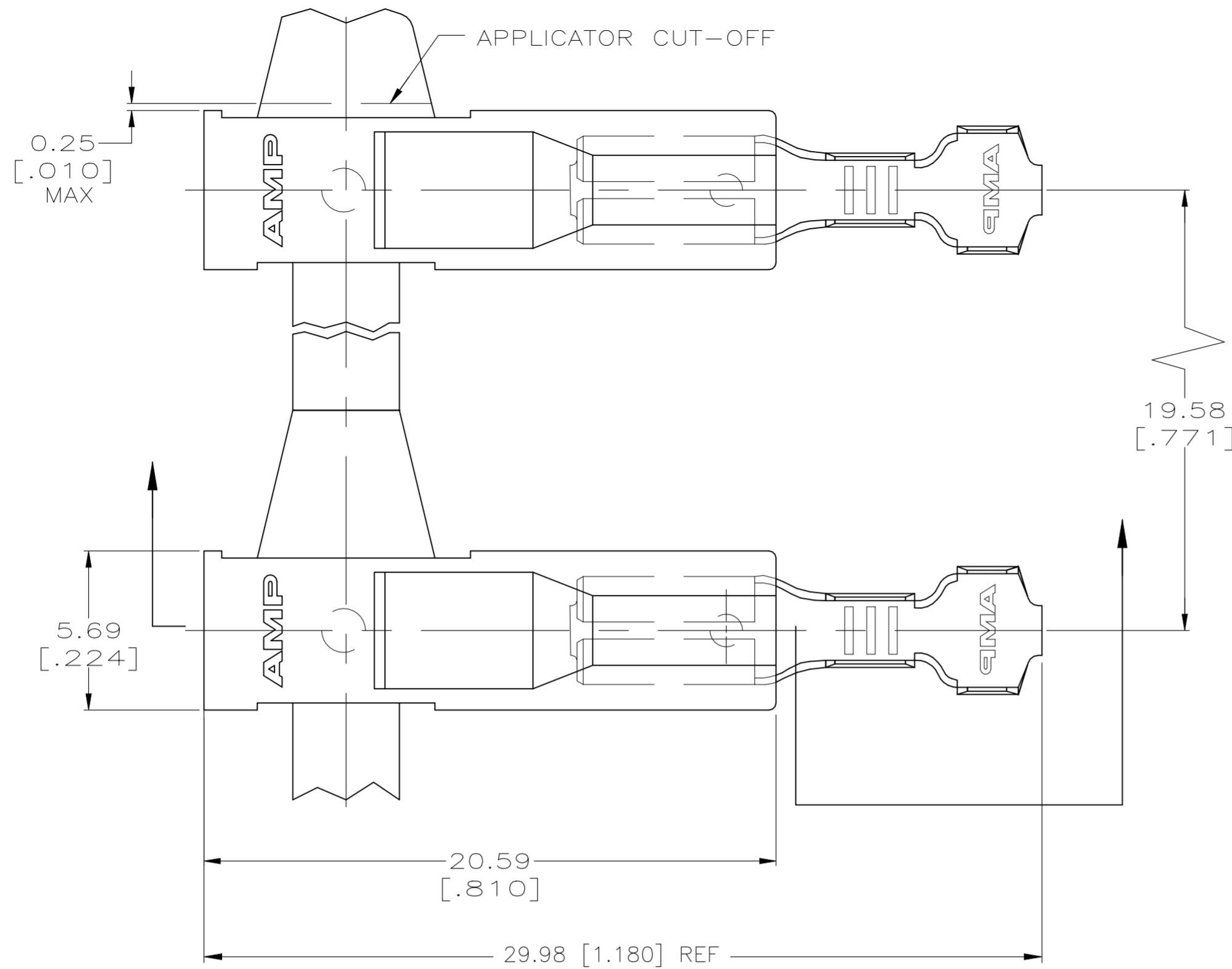

- 1 MATING TAB THK IS 0.81±0.025[.032±.001]
- 2 WIRE SIZE IS [#22-#18] AWG.
- 3 INSULATION RANGE IS 2.03-3.05[.080-.120] DIA.
- 4 PREPRODUCTION - FASR REQ

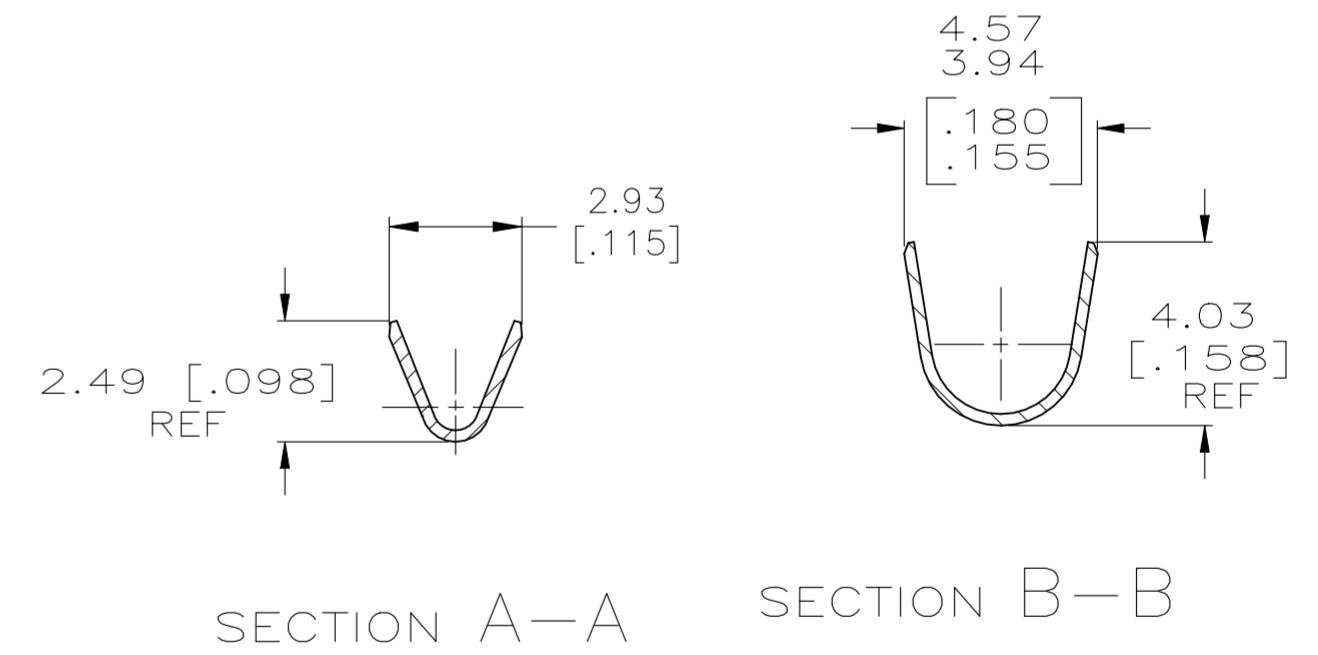
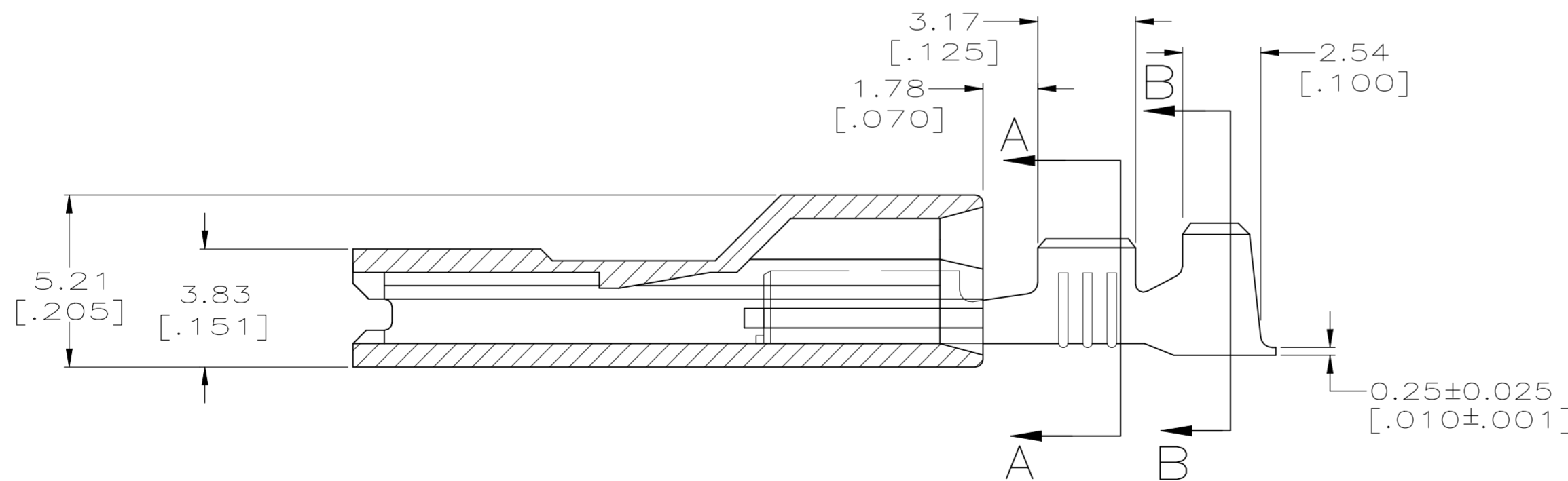

SUPERSEDED BY 521437-2

TIN PLATE		521437-2	
TERMINAL FINISH		PART NO.	
DWN JR RUTH 22OCT01		4 521437-1	
CHK J HUMMEL 22OCT01		TE Connectivity	
APVD J HUMMEL 22OCT01		NAME	
PRODUCT SPEC 108-1285		ASSEMBLY, RECEPTACLE, ULTRA-POD, 2.79 [.110] SERIES	
APPLICATION SPEC 114-2124		SIZE A2	CAGE CODE 00779
MATERIAL TERM - BRASS HSG - 6/6 NYLON, V0		DRAWING NO C=521437	RESTRICTED TO -
FINISH SEE TABLE HSG - WHITE		SCALE 6:1	SHEET 1 OF 1
CUSTOMER DRAWING		REV F2	

THIS DRAWING IS A CONTROLLED DOCUMENT.	
DIMENSIONS: mm [INCHES]	TOLERANCES UNLESS OTHERWISE SPECIFIED:
0 PLC ± -	1 PLC ± -
1 PLC ± -	2 PLC ± 0.25 [.010]
2 PLC ± -	3 PLC ± -
3 PLC ± -	4 PLC ± -
4 PLC ± -	ANGLES ± -