

OVERVIEW

Ceiling mounted lens for high bay areas such as warehouses, distribution centres, factories and atriums. Designed to function with a single pyro but can be configured with three pyro's for additional sensitivity.

FEATURES

- Array of 43 Individual Fresnel Facets
- Up to 172 detection zones with a single qual pyro
- Up to 516 detection zones with a three pyro arrangement
- Aspheric Fresnels for better optical performance
- Designed using optical ray-tracing software
- Other flange shapes can be cropped from rectangle
- Available in natural and white colours

Part Number	Drawing	Colour
533C	A3-10533	Natural
533W	A3-10533	White

APPLICATIONS

- PIR detection for warehouses, shops, offices and workshops
- Lighting and air conditioning control
- Alarms and security

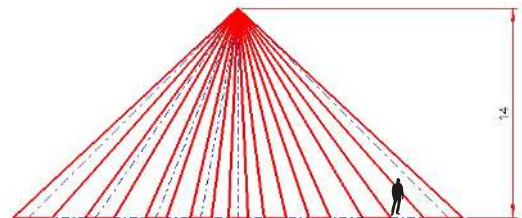
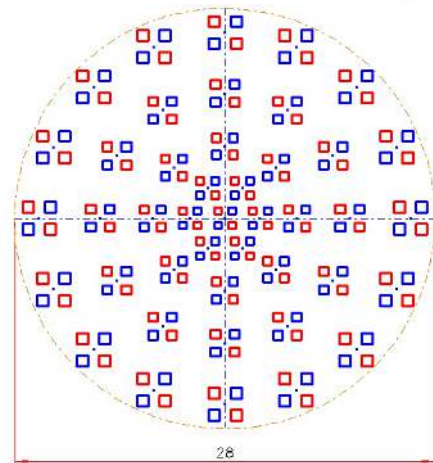

Theoretical zone plot. Optimum range is 12m.
Maximum Range 14m depending on electronic gain

Diagram shows theoretical zone plot for detector mounted 14m above floor. Mounting height can be reduced as required. The lens has a 1:1 aspect ratio, therefore when mounted at 12m height, the lens projects 43 zones into a 24m diameter floorspace.

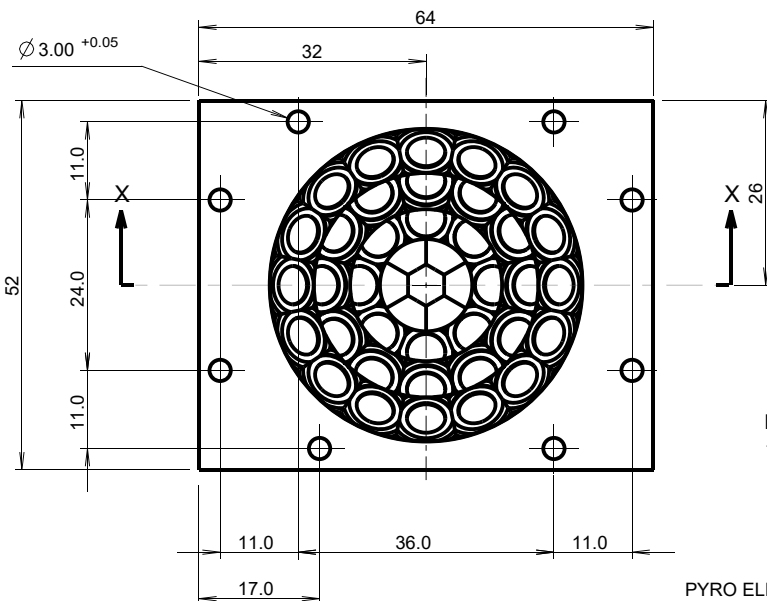

PYRO ELEMENT POSITION
(TYP. PYRO LHi1128 QUAD)

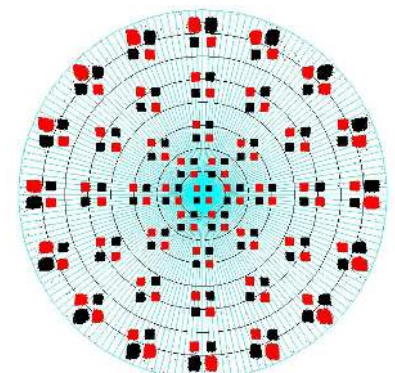
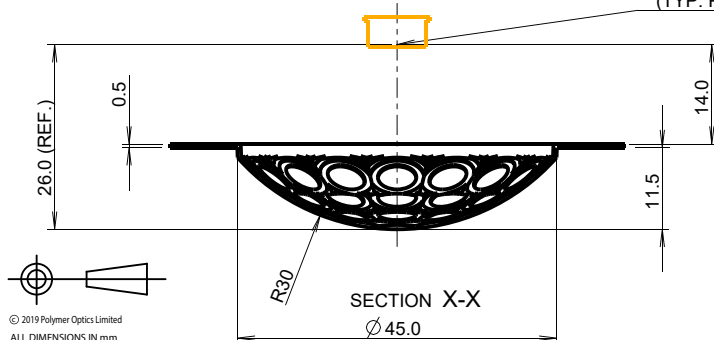

Zone plot using optical ray-tracing software

HIGH BAY LENS

PIR lens for motion detection. For use in security or lighting control applications where there are relatively high ceilings.

3 PYRO MODE

To improve the density of the zone pattern, and hence to increase detection sensitivity, the High Bay lens can also be used in a 3 pyro configuration.

We recommend tilting the pyro's according to the pictures below. A pyro holder design is available to download from the POL website. It can be used to 3D print a prototype holder, or it can be used under licence to manufacture a plastic mould tool.



APPLICATIONS

- Warehouses and factories
- Atriums
- Leisure centres, gyms, sports halls
- Street Lights, Car Parks

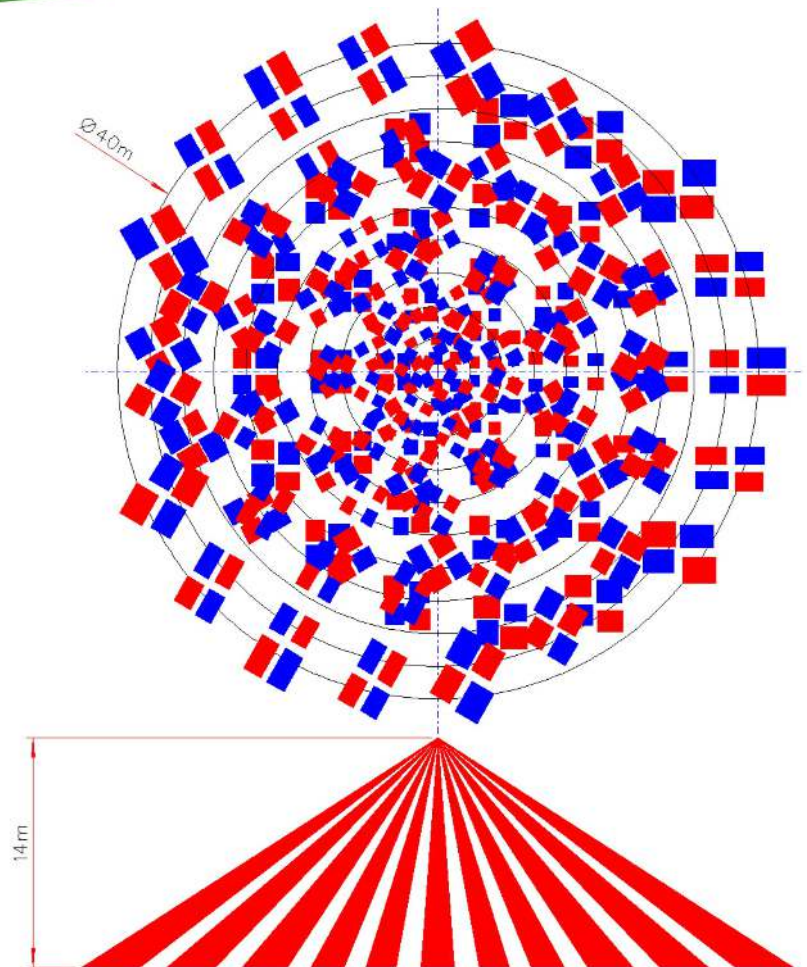
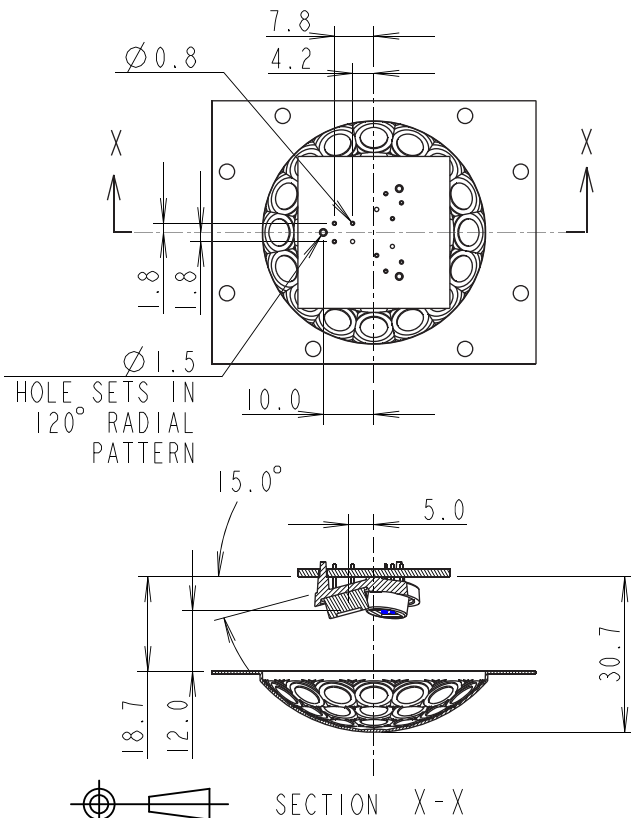

Diagram shows theoretical zone plot for detector mounted 14m above floor. Mounting height can be reduced as required. When used with a quad pyro the lens will project 516 individual detection zones within a 40m diameter circular area.