

# THS4521/2/4EVM

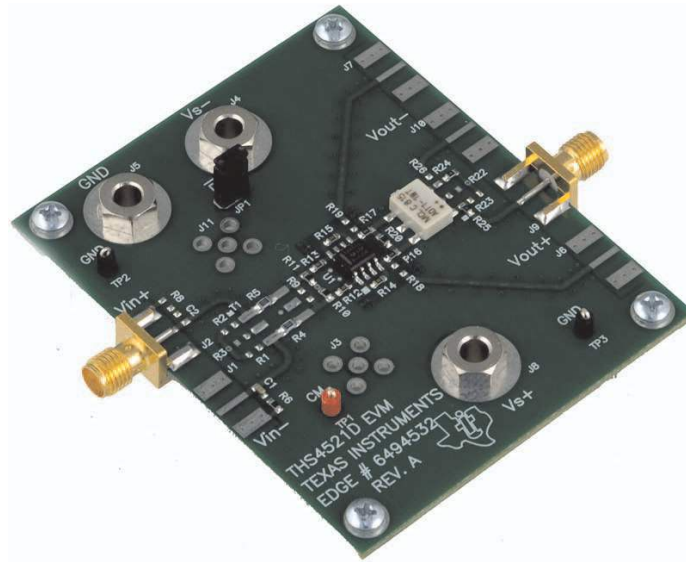

**THS4521EVM**

**Features:**

- Configured for split-supply operation; easily modified for single-supply operation.
- Default single-ended input configuration can easily be reconfigured for differential input.
- Default single-ended output configuration can easily be reconfigured for differential output.
- Designed for easy connection to standard 50-Ω input/output impedance test equipment.
- Inputs and outputs include SMA connectors.

**Contents**

1	Description .....	2
2	Power Connections .....	3
3	Input and Output Connections .....	3
4	THS4521EVM Schematic, Layout, and Bill of Materials (BOM) .....	4
5	THS4522EVM Schematic, Layout, and Bill of Materials (BOM) .....	7
6	THS4524EVM Schematic, Layout, and Bill of Materials (BOM) .....	10

**List of Figures**

1	THS4521EVM Schematic.....	5
2	THS4521EVM: Top Layer (Layer 1).....	6
3	THS4521EVM: Ground Layer (Layer 2) .....	6
4	THS4521EVM: Ground Layer (Layer 3) .....	6
5	THS4521EVM: Bottom Layer (Layer 4).....	6

All trademarks are the property of their respective owners.

6	THS4522EVM: Schematic 1 .....	8
7	THS4522EVM: Schematic 2 .....	8
8	THS4522EVM: Top Layer (Layer 1) .....	9
9	THS4522EVM: Ground Layer (Layer 2) .....	9
10	THS4522EVM: Ground Layer (Layer 3) .....	9
11	THS4522EVM: Bottom Layer (Layer 4) .....	9
12	THS4524EVM: Schematic 1 .....	11
13	THS4524EVM: Schematic 2 .....	11
14	THS4524EVM: Schematic 3 .....	12
15	THS4524EVM: Schematic 4 .....	12
16	THS4524EVM: Top Layer (Layer 1) .....	13
17	THS4524EVM: Ground Layer (Layer 2) .....	13
18	THS4524EVM: Ground Layer (Layer 3) .....	13
19	THS4524EVM: Bottom Layer (Layer 4) .....	13

### List of Tables

1	EVM Specifications .....	2
2	Jumper Configuration .....	3
3	THS4521 Parts List .....	4
4	THS4522EVM Parts List .....	7
5	THS4524EVM Parts List .....	10

## 1 Description

The [THS4521](#), [THS4522](#), and [THS4524](#) family of devices are very low-power, fully differential operational amplifiers with rail-to-rail output and an input common-mode range that includes the negative rail. These amplifiers are designed for low-power data-acquisition systems and high-density applications where power dissipation is a critical parameter.

The THS4521EVM is an evaluation module (EVM) for the single version, THS4521, in an SO-8 (D) package. The THS4522EVM is an evaluation module for the dual version, THS4522, in a TSSOP-16 (PW) package. The THS4524EVM is an evaluation module for the quad version, THS4524, in a TSSOP-32 (DBT) package.

The THS4521/2/4EVMs are designed to quickly and easily demonstrate the functionality and versatility of these amplifiers. Each EVM is ready to connect to power, a signal source, and a variety of test instruments through the use of onboard connectors. The default amplifier configuration for each module is a single-ended input, single-ended output (via transformer), and split-supply operation. The EVMs can be easily configured for differential input, differential output, and single-supply operation. Throughout this document, the acronym *EVM* and the phrases *evaluation module* and *evaluation board* are synonymous with the THS4521/2/4EVMs. For clarity of reading, the abbreviation *THS4521/2/4EVMs* refers to the THS4521EVM, THS4522EVM, and THS4524EVM, unless otherwise noted.

The electrical specifications for the THS4521/2/4EVMs are summarized in [Table 1](#).

**Table 1. EVM Specifications**

Parameter	Units
Single-supply voltage range ( $V_{S-}$ = ground)	2.5 V to 5.5 V
Split Supply voltage range ( $V_{S\pm}$ )	$\pm 1.25$ V to 2.75 V
Supply current ( $I_{S\pm}$ )	1.1 mA/A, typ
Input voltage ( $V_I$ )	$V_{S\pm}$ , max
Output drive ( $I_O$ )	$\pm 55$ mA, typ

## 2 Power Connections

The THS4521/2/4EVMs are equipped with banana jacks for easy power connections. The positive supply input is labeled  $V_{S+}$ . The negative supply input is labeled  $V_{S-}$ . Ground is labeled *GND*.

### 2.1 Split-Supply Operation

For split-supply operation, apply the positive supply voltage to  $V_{S+}$ , the negative supply voltage to  $V_{S-}$ , and the ground reference from supply to *GND*.

### 2.2 Single-Supply Operation

For single-supply operation, connect  $V_{S-}$  to *GND* with a jumper, and apply the positive supply voltage to  $V_{S+}$ .

## 3 Input and Output Connections

The THS4521/2/4EVMs are equipped with SMA connectors for easy connection of signal generators and analysis equipment. As shipped from the factory, the EVMs are configured for single-ended input and output with termination for connection to 50-Ω test equipment. For best results, the signal should be routed to and from the EVM with cables that have 50-Ω characteristic impedance. Refer to the [THS4521](#), [THS4522](#), [THS4524 product data sheet](#), and the schematics and layouts provided in this user guide for details on how to reconfigure the EVM board for differential input or output operation.

### 3.1 Power-Down Operation

The THS4521/2/4EVMs enable normal operation of the respective devices, or they can each be placed into a power-down mode through the placement of jumpers, as shown in [Table 2](#).

**Table 2. Jumper Configuration**

EVM	Jumper	Operating Mode
THS4521EVM	JP1	Open
		Shorted
THS4522EVM	JP1	Open
		Shorted
	JP2	Open
		Shorted
THS4524EVM	JP1	Open
		Shorted
	JP2	Open
		Shorted
	JP3	Open
		Shorted
	JP4	Open
		Shorted

#### 4 THS4521EVM Schematic, Layout, and Bill of Materials (BOM)

Table 3 lists the bill of materials for the THS4521EVM.

Figure 1 through Figure 5 show the schematic and printed circuit board (PCB) layouts, respectively, for the THS4521EVM.

**Table 3. THS4521 Parts List**

Item	Description	SMD Size	Reference Designator	Qty	Manufacturer Part Number
1	Capacitor, 10.0 $\mu$ F, ceramic, X5R, 6.3 V	0805	C7-C10	4	(AVX) 08056D106KAT2A
2	Capacitor, 0.1 $\mu$ F, ceramic, X7R, 16 V	0603	C3, C5, C11, C12	4	(AVX) 0603YC104KAT2A
3	Capacitor, 0.22 $\mu$ F, ceramic, X7R, 10 V	0603	C1, C4, C6	3	(AVX) 0603ZC224KAT2A
4	Open	0603	C2, C13-C16	5	
5	Open	0603	R1-R3, R7-R9, R18, R19, R21-R23, R26	12	
6	Resistor, 0 $\Omega$	0603	R24, R25	2	(ROHM) MCR03EZPJ000
7	Resistor, 49.9 $\Omega$ , 1/10W, 1%	0603	R6	1	(ROHM) MCR03EZPFX49R9
8	Resistor, 52.3 $\Omega$ , 1/10W, 1%	0603	R10, R11, R20	3	(ROHM) MCR03EZPFX52R3
9	Resistor, 487 $\Omega$ , 1/10W, 1%	0603	R16, R17	2	(ROHM) MCR03EZPFX4870
10	Resistor, 1k $\Omega$ , 1/10W, 1%	0603	R12-R15	4	(ROHM) MCR03EZPFX1001
11	Resistor, 0 $\Omega$	0805	R4, R5	2	(ROHM) MCR10EZPJ000
12	Open		T1	1	
13	Transformer, RF		T2	1	(MINI-CIRCUITS) ADT1-1WT
14	Jack, banana receptance, 0.25-in diameter hole		J4, J5, J8	3	(SPC) 813
15	Open		J1, J3, J6, J7, J10, J11	6	
16	Connector, edge, SMA PCB jack		J2, J9	2	(JOHNSON) 142-0701-801
17	Header, 0.1 in CTRS, 0.025-in sq. pins	2 POS.	JP1	1	(SULLINS) PBC36SAAN
18	Shunts		JP1	1	(SULLINS) SSC02SYAN
19	Test point, red		TP1	1	(KEYSTONE) 5000
20	Test point, black		TP2, TP3	2	(KEYSTONE) 5001
21	IC, THS4521		U1	1	(TI) THS4521D
22	Standoff, 4-40 hex, 0.625 in			4	(KEYSTONE) 1808
23	Screw, Phillips, 4-40, 0.250 in			4	SHR-0440-016-SN
24	Board, printed circuit			1	(TI) EDGE# 6494532

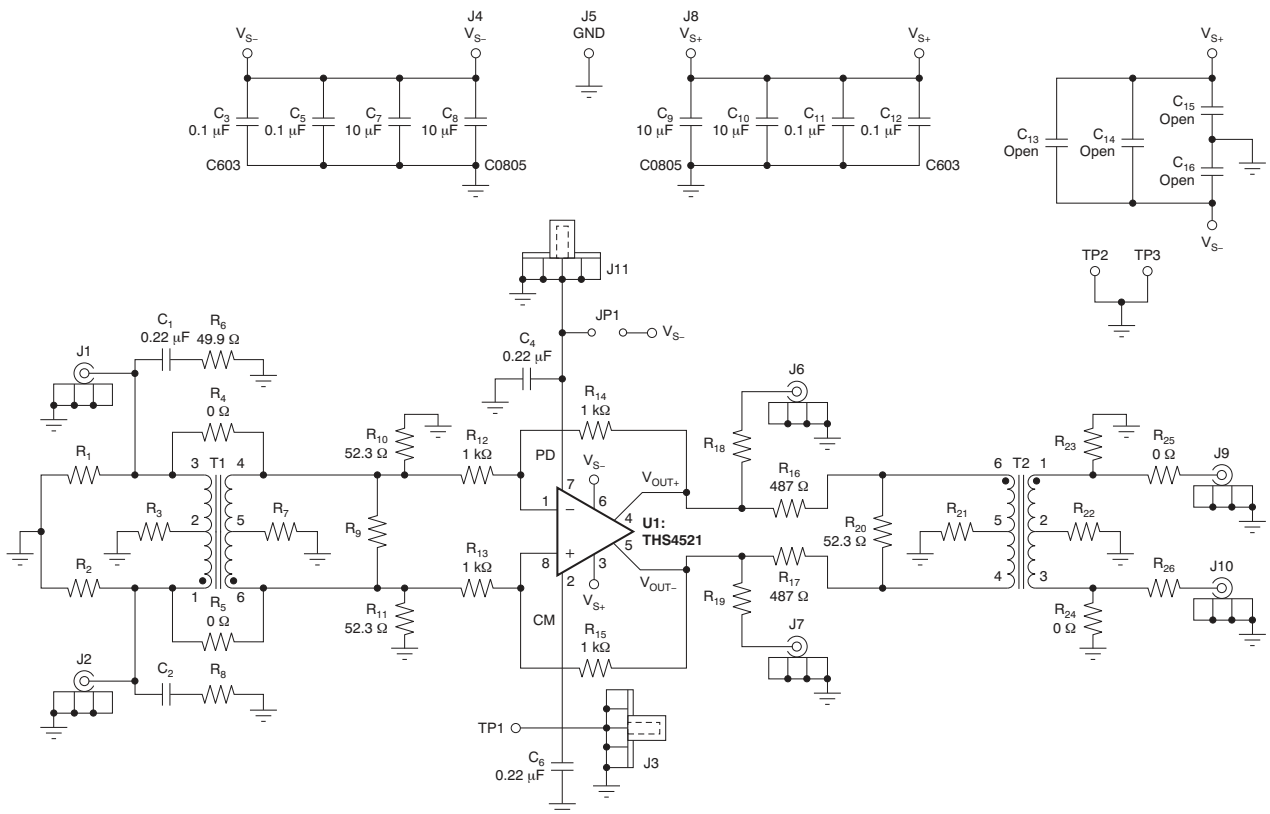

**Figure 1. THS4521EVM Schematic**



## 5 THS4522EVM Schematic, Layout, and Bill of Materials (BOM)

Table 4 lists the bill of materials for the THS4522EVM.

Figure 6 through Figure 11 show the schematic and PCB layouts, respectively, for the THS4522EVM.

**Table 4. THS4522EVM Parts List**

Item	Description	SMD Size	Reference Designator	Qty	Manufacturer Part Number
1	Capacitor, 10.0 $\mu$ F, ceramic, X5R, 6.3 V	0805	C7-C10	4	(AVX) 08056D106KAT2A
2	Capacitor, 0.1 $\mu$ F, ceramic, X7R, 16 V	0603	C3, C5, C11, C12	4	(AVX) 0603YC104KAT2A
3	Capacitor, 0.22 $\mu$ F, ceramic, X7R, 10 V	0603	C2, C4, C6, C18-C20	6	(AVX) 0603ZC224KAT2A
4	Open	0603	C1, C13-C17, C21-C24	10	
5	Resistor, 52.3 $\Omega$ , 1/16W, 1%	0402	R10, R11, R36, R37	4	(KOA) RK73H1ETTP52R3F
6	Resistor, 487 $\Omega$ , 1/16W, 1%	0402	R16, R17, R42, R43	4	(KOA) RK73H1ETTP4870F
7	Resistor, 1 k $\Omega$ , 1/16W, 1%	0402	R12-R15, R38-R41	8	(KOA) RK73H1ETTP1001F
8	Open	0603	R1-R3, R6-R8, R19, R22, R23, R26-R29, R32-R34, R45, R48, R49, R52	20	
9	Resistor, 0 $\Omega$	0603	R24, R25, R50, R51	4	(ROHM) MCR03EZPJ000
10	Resistor, 49.9 $\Omega$ , 1/10W, 1%	0603	R9, R35	2	(ROHM) MCR03EZPFX49R9
11	Resistor, 52.3 $\Omega$ , 1/10W, 1%	0603	R18, R44	2	(ROHM) MCR03EZPFX52R3
12	Open	0805	R20, R21, R46, R47	4	
13	Resistor, 0 $\Omega$	0805	R4, R5, R30, R31	4	(ROHM) MCR10EZPJ000
14	Open		T1, T3	2	
15	Transformer, RF		T2, T4	2	(MINI-CIRCUITS) ADT1-1WT
16	Jack, banana receptance, 0.25-in diameter hole		J3-J5	3	(SPC) 813
17	Open		J1, J7, J8, J11-J15	8	
18	Connector, edge, SMA PCB jack		J2, J6, J9, J10	4	(JOHNSON) 142-0701-801
19	Header, 0.1 in CTRS, 0.025-in sq. pins	2 POS.	JP1, JP2	2	(SULLINS) PBC36SAAN
20	Shunts		JP1, JP2	2	(SULLINS) SSC02SYAN
21	Test point, red		TP1, TP4	2	(KEYSTONE) 5000
22	Test point, black		TP2, TP3	2	(KEYSTONE) 5001
23	IC, THS4522		U1	1	(TI) THS4522PW
24	Standoff, 4-40 hex, 0.625 in			4	(KEYSTONE) 1808
25	Screw, Phillips, 4-40, 0.250 in			4	(BF) PMS4400031PH
26	Board, printed circuit			1	(TI) EDGE# 6494533, REV.A

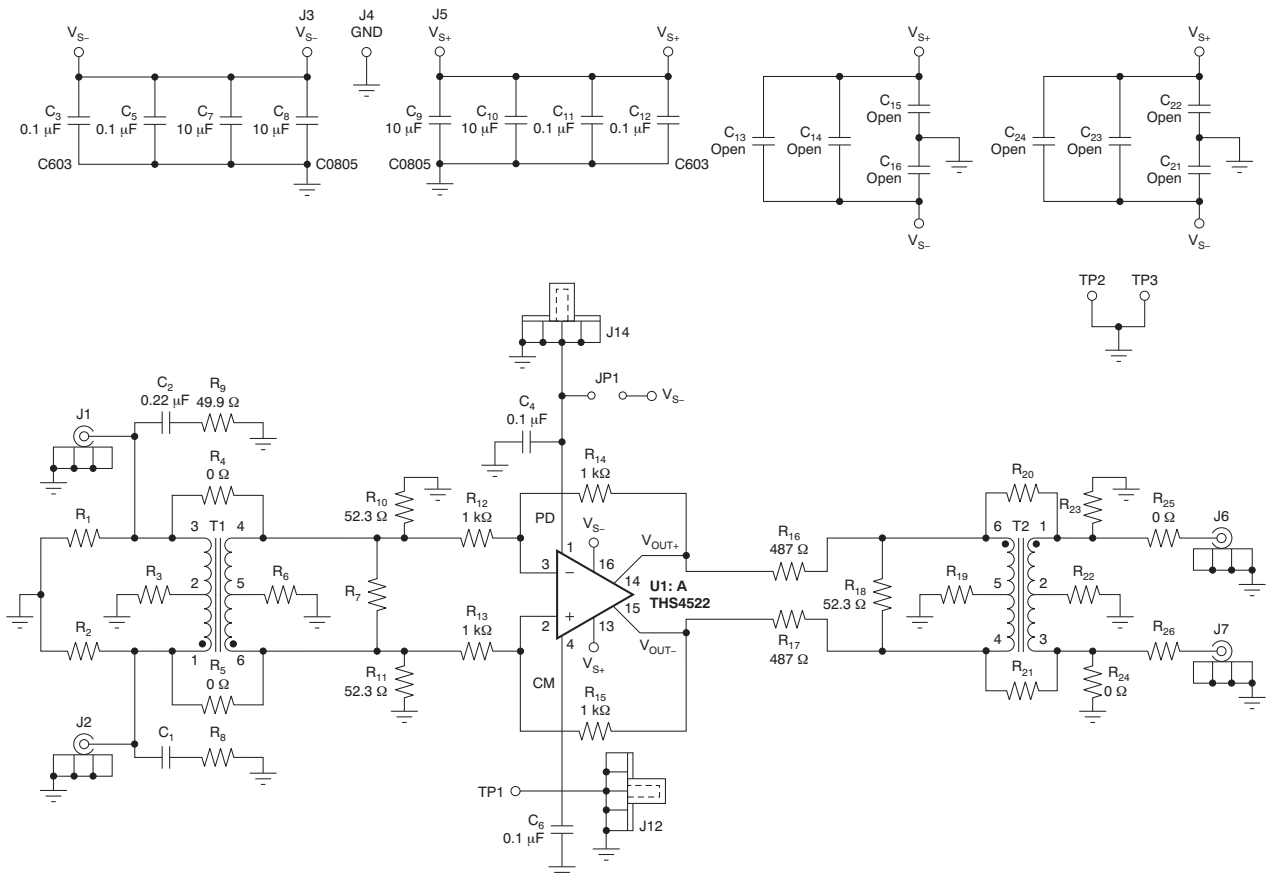

Figure 6. THS4522EVM: Schematic 1

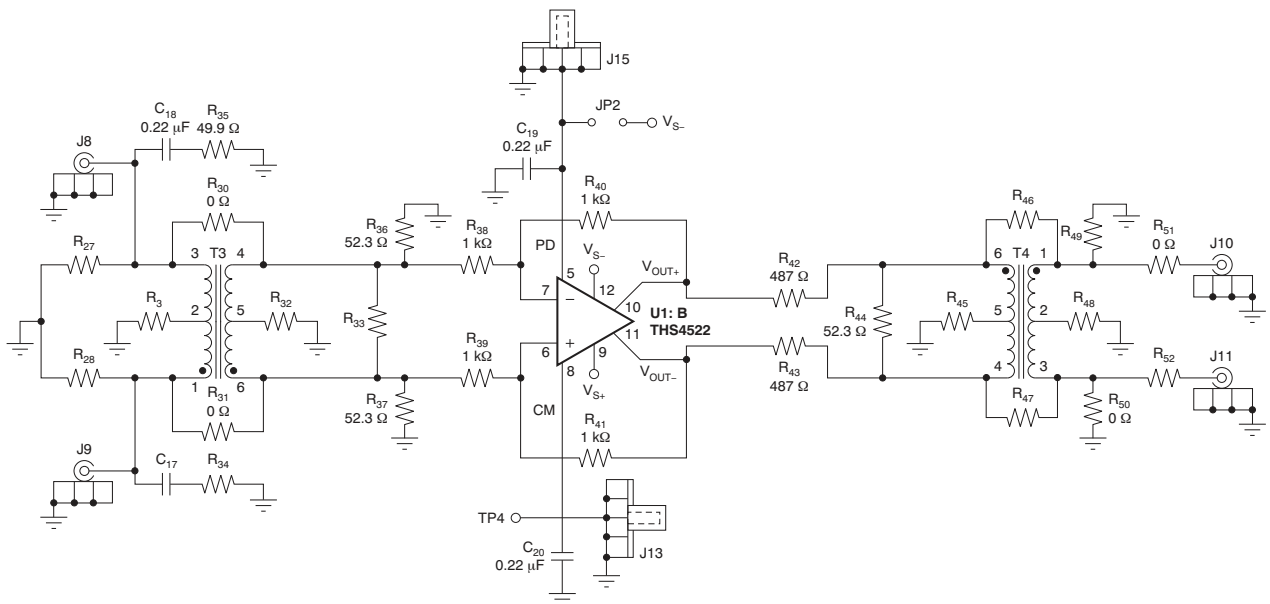

Figure 7. THS4522EVM: Schematic 2



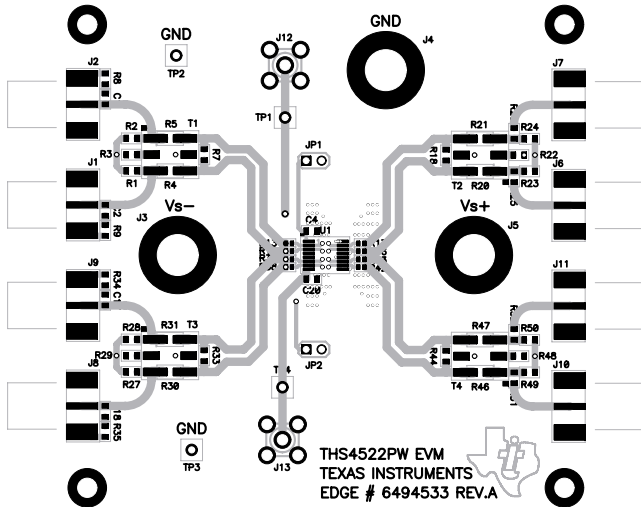

Figure 8. THS4522EVM: Top Layer (Layer 1)

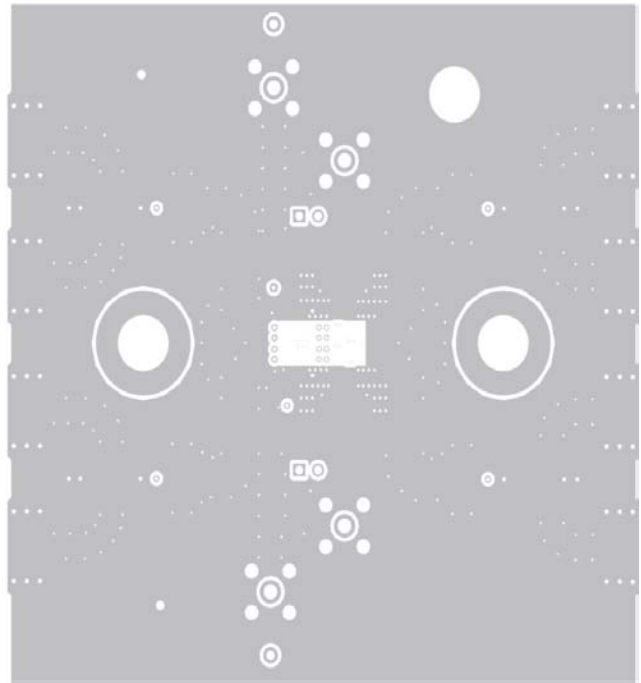

Figure 9. THS4522EVM: Ground Layer (Layer 2)

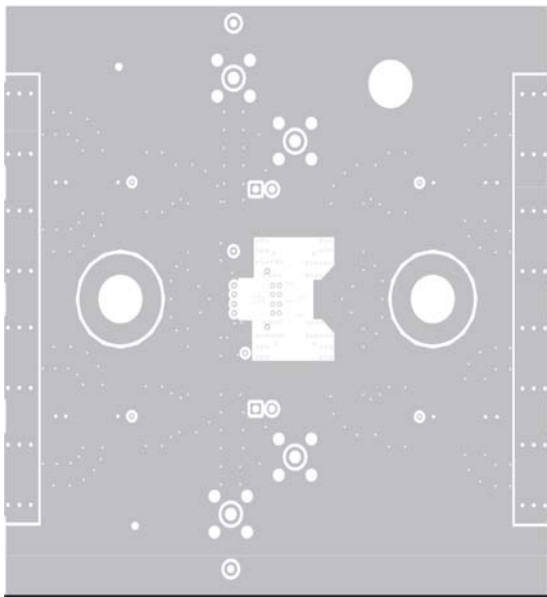

Figure 10. THS4522EVM: Ground Layer (Layer 3)

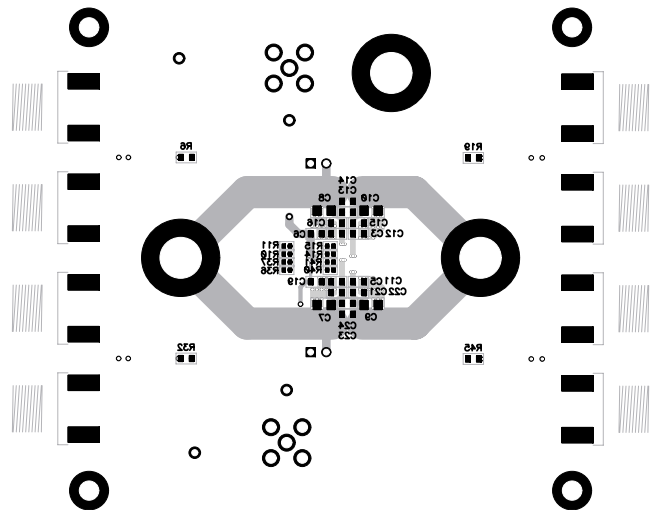

Figure 11. THS4522EVM: Bottom Layer (Layer 4)

## 6 THS4524EVM Schematic, Layout, and Bill of Materials (BOM)

Table 5 lists the bill of materials for the THS4524EVM.

Figure 12 through Figure 19 show the schematics and PCB layouts, respectively, for the THS4524EVM.

**Table 5. THS4524EVM Parts List**

Item	Description	SMD Size	Reference Designator	Qty	Manufacturer Part Number
1	Capacitor, 10.0 $\mu$ F, ceramic, X5R, 6.3 V	805	C7-C10, C33	5	(AVX) 08056D106KAT2A
2	Open	402	C29-C32	4	
3	Capacitor, 0.1 $\mu$ F, ceramic, X7R, 16 V	402	C3, C5, C11-C16, C34-C37	12	(MURATA) GRM155R71C104KA88D
4	Capacitor, 0.22 $\mu$ F, ceramic, X7R, 10 V	603	C2, C4, C6, C18-C21, C23-C25, C27, C28	12	(AVX) 0603ZC224KAT2A
5	Open	603	C1, C17, C22, C26	4	
6	Resistor, 52.3 $\Omega$ , 1/16W, 1%	402	R10, R11, R36, R37, R53, R54, R79, R90	8	(KOA) RK73H1ETTP52R3F
7	Resistor, 487 $\Omega$ , 1/16W, 1%	402	R16, R17, R42, R43, R77, R78, R103, R104	8	(KOA) RK73H1ETTP4870F
8	Resistor, 1 k $\Omega$ , 1/16W, 1%	402	R12-R15, R38-R41, R70, R71, R74, R76, R96, R97, R100, R102	16	(KOA) RK73H1ETTP1001F
9	Open	603	R1-R3, R6-R8, R19, R22, R23, R26-R29, R32-R34, R45, R48, R49, R52, R57, R59, R60, R62, R63, R65, R66, R69, R72, R75, R83, R85, R86, R88, R89, R91, R92, R95, R98, R101	40	
10	Resistor, 0 $\Omega$	603	R24, R25, R50, R51, R55, R73, R81, R99	8	(ROHM) MCR03EZPJ000
11	Resistor, 49.9 $\Omega$ , 1/10W, 1%	603	R9, R35, R61, R87	4	(ROHM) MCR03EZPFX49R9
12	Resistor, 52.3 $\Omega$ , 1/10W, 1%	603	R18, R44, R64, R90	4	(ROHM) MCR03EZPFX52R3
13	Open	805	R20, R21, R46, R47, R56, R58, R82, R84	8	
14	Resistor, 0 $\Omega$	805	R4, R5, R30, R31, R67, R68, R93, R94	8	(ROHM) MCR10EZPJ000
15	Open		T1, T3, T5, T7	4	
16	Transformer, RF		T2, T4, T6, T8	4	(MINI-CIRCUITS) ADT1-1WT
17	Jack, banana receptance, 0.25-in diameter hole	2 POS.	J3, J4, J5	3	(SPC) 813
18	Open		J1, J7, J8, J11, J13, J14, J17, J18, J20-J27	16	
19	Connector, edge, SMA PCB jack		J2, J6, J9, J10, J12, J15, J16, J19	8	(JOHNSON) 142-0701-801
20	Header, 0.1 in CTRS, 0.025-in sq. pins		JP1-JP4	4	(SULLINS) PBC36SAAN
21	Shunts		JP1-JP4	4	(SULLINS) SSC02SYAN
22	Test point, red		TP1, TP4-TP6	4	(KEYSTONE) 5000
23	Test point, black		TP2, TP3	2	(KEYSTONE) 5001
24	IC, THS4524		U1	1	(TI) THS4524DBT
25	Standoff, 4-40 hex, 0.625 in			4	(KEYSTONE) 1808
26	Screw, Phillips, 4-40, 0.250 in			4	(BF) PMS4400031PH
27	Board, printed circuit			1	(TI) EDGE# 6494534, REV.A

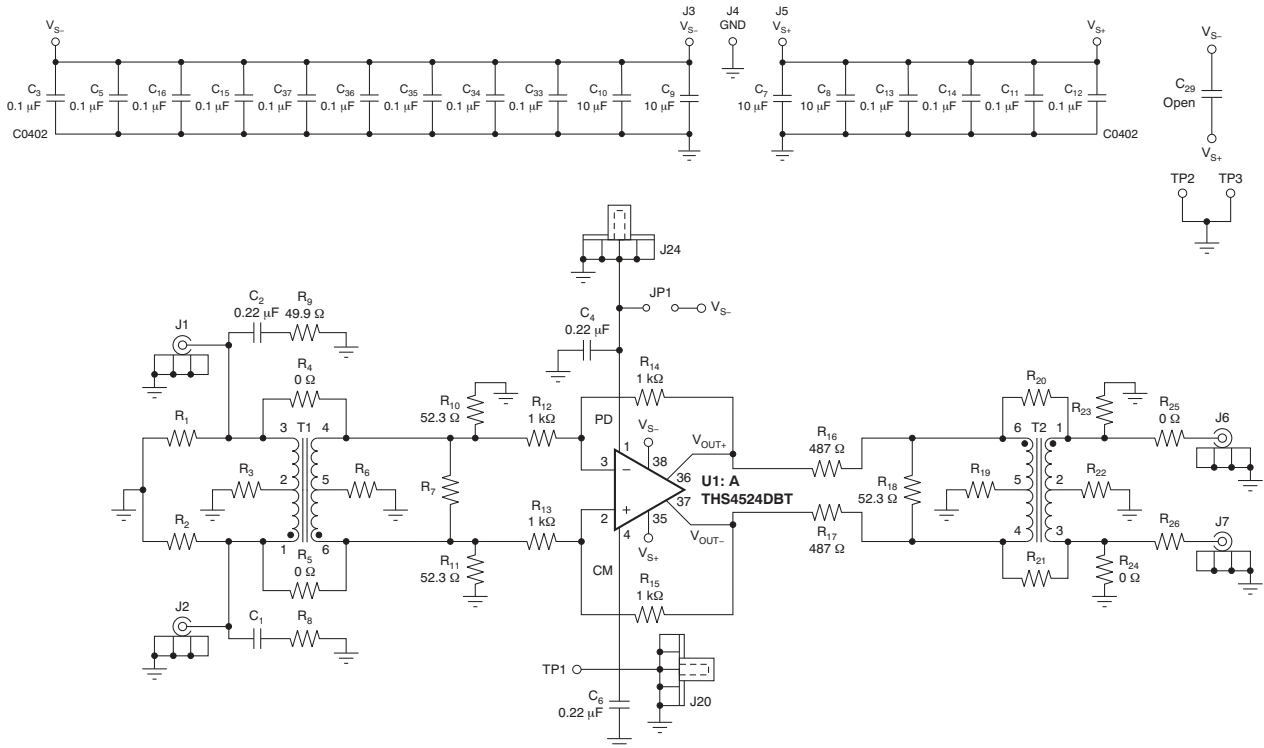

**Figure 12. THS4524EVM: Schematic 1**

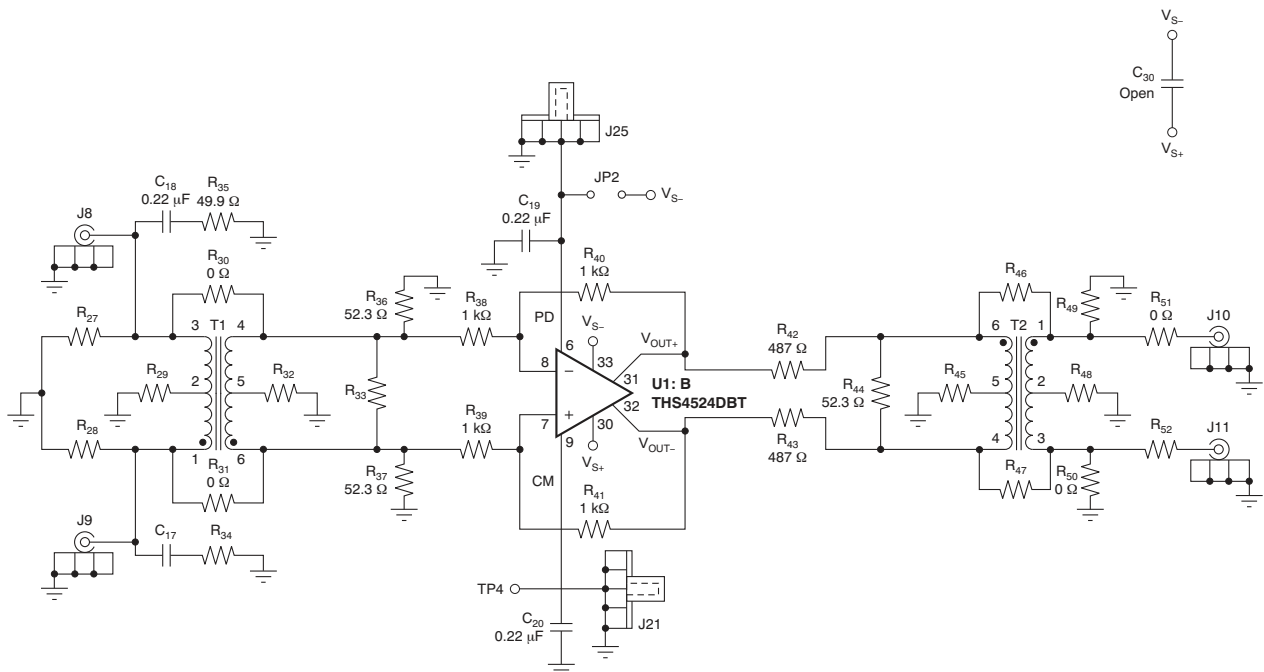

**Figure 13. THS4524EVM: Schematic 2**

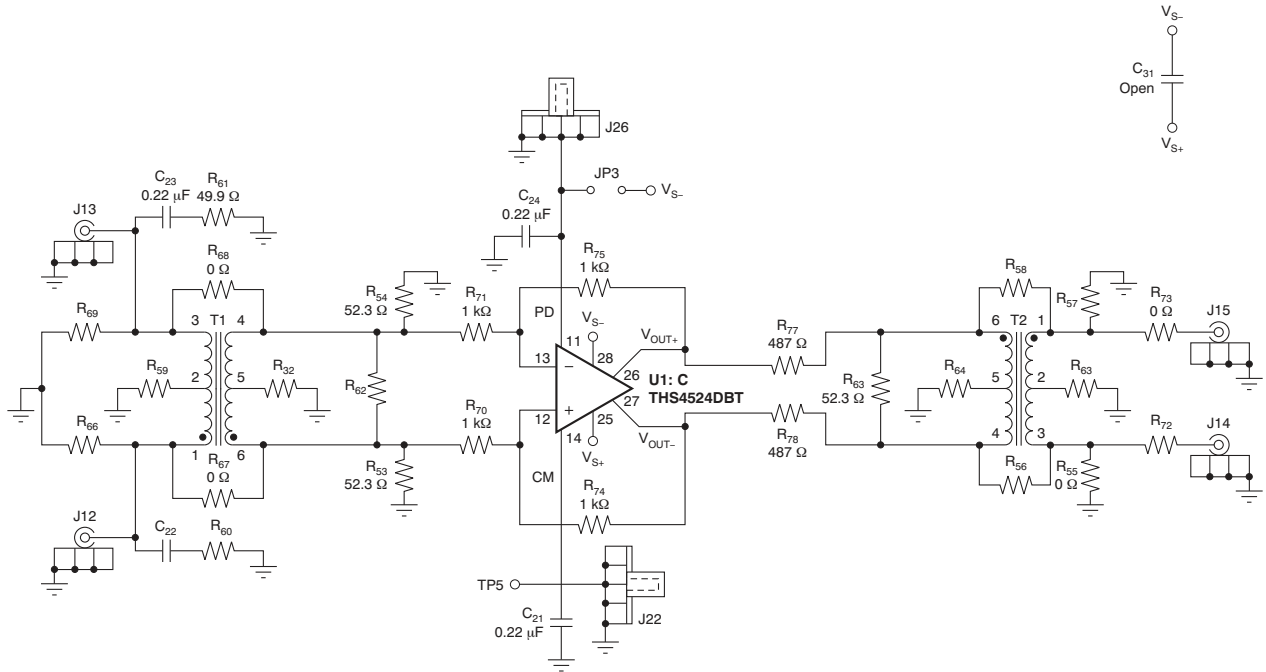

Figure 14. THS4524EVM: Schematic 3

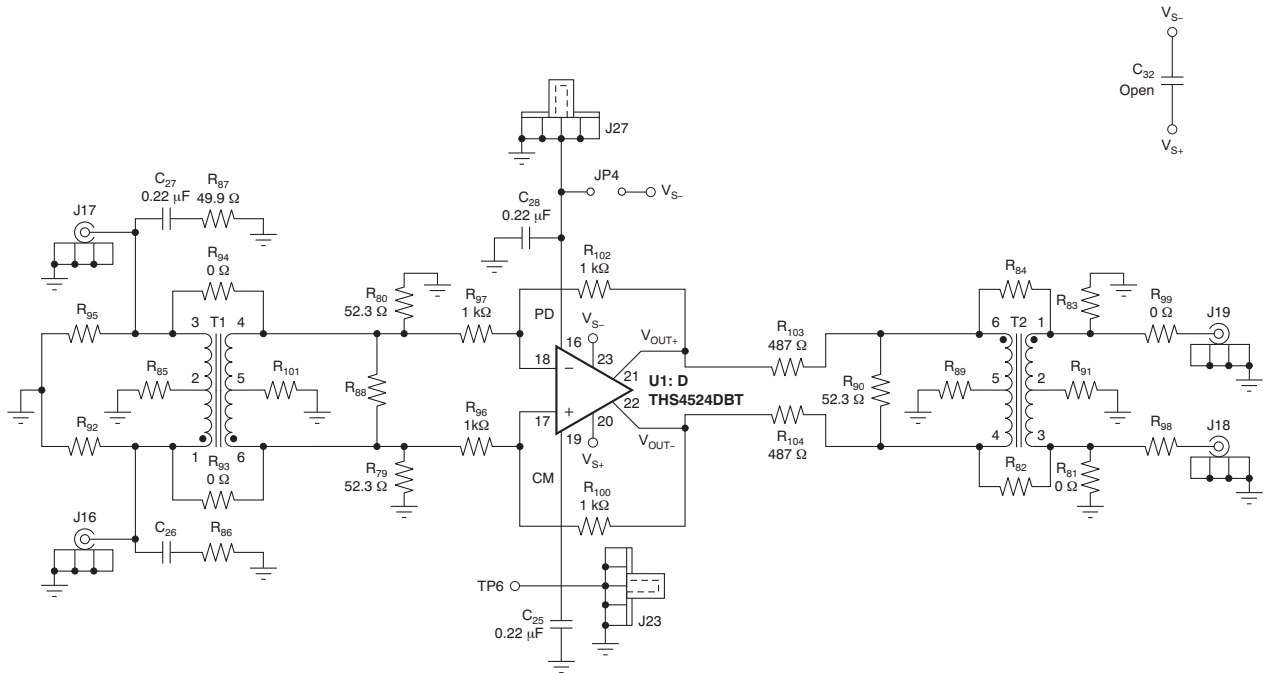

Figure 15. THS4524EVM: Schematic 4

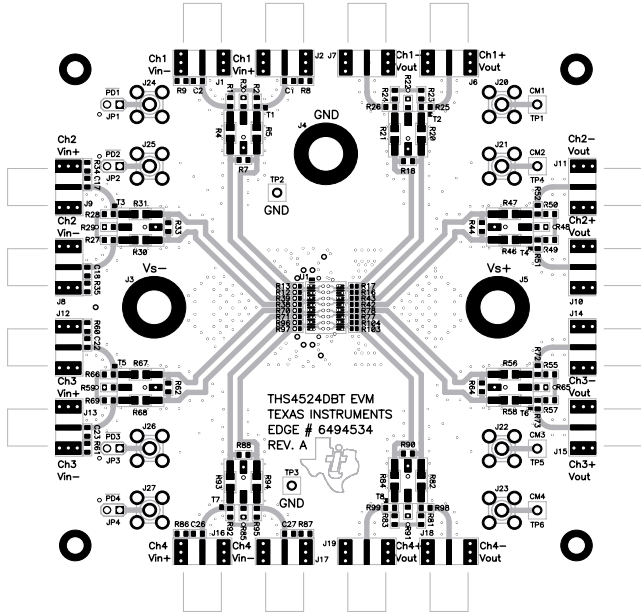

Figure 16. THS4524EVM: Top Layer (Layer 1)

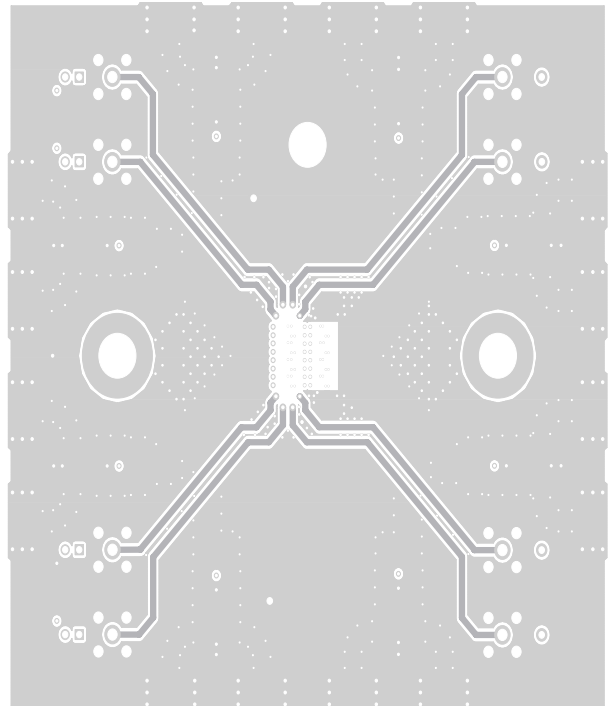

Figure 17. THS4524EVM: Ground Layer (Layer 2)

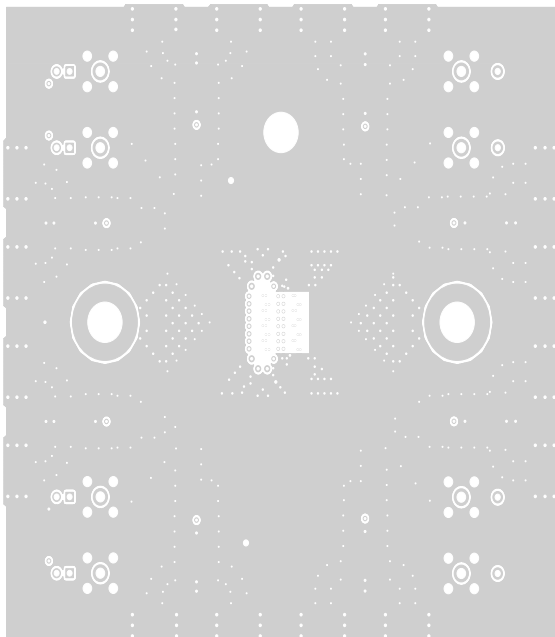

Figure 18. THS4524EVM: Ground Layer (Layer 3)

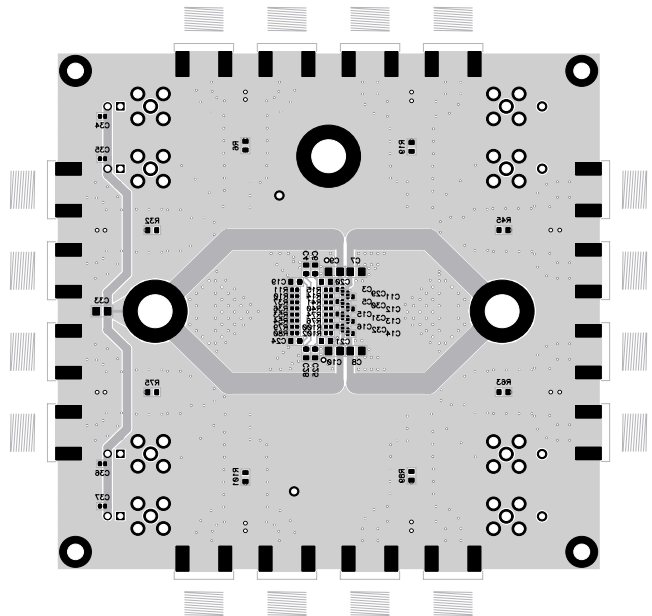

Figure 19. THS4524EVM: Bottom Layer (Layer 4)

## EVALUATION BOARD/KIT IMPORTANT NOTICE

Texas Instruments (TI) provides the enclosed product(s) under the following conditions:

This evaluation board/kit is intended for use for **ENGINEERING DEVELOPMENT, DEMONSTRATION, OR EVALUATION PURPOSES ONLY** and is not considered by TI to be a finished end-product fit for general consumer use. Persons handling the product(s) must have electronics training and observe good engineering practice standards. As such, the goods being provided are not intended to be complete in terms of required design-, marketing-, and/or manufacturing-related protective considerations, including product safety and environmental measures typically found in end products that incorporate such semiconductor components or circuit boards. This evaluation board/kit does not fall within the scope of the European Union directives regarding electromagnetic compatibility, restricted substances (RoHS), recycling (WEEE), FCC, CE or UL, and therefore may not meet the technical requirements of these directives or other related directives.

Should this evaluation board/kit not meet the specifications indicated in the User's Guide, the board/kit may be returned within 30 days from the date of delivery for a full refund. **THE FOREGOING WARRANTY IS THE EXCLUSIVE WARRANTY MADE BY SELLER TO BUYER AND IS IN LIEU OF ALL OTHER WARRANTIES, EXPRESSED, IMPLIED, OR STATUTORY, INCLUDING ANY WARRANTY OF MERCHANTABILITY OR FITNESS FOR ANY PARTICULAR PURPOSE.**

The user assumes all responsibility and liability for proper and safe handling of the goods. Further, the user indemnifies TI from all claims arising from the handling or use of the goods. Due to the open construction of the product, it is the user's responsibility to take any and all appropriate precautions with regard to electrostatic discharge.

**EXCEPT TO THE EXTENT OF THE INDEMNITY SET FORTH ABOVE, NEITHER PARTY SHALL BE LIABLE TO THE OTHER FOR ANY INDIRECT, SPECIAL, INCIDENTAL, OR CONSEQUENTIAL DAMAGES.**

TI currently deals with a variety of customers for products, and therefore our arrangement with the user **is not exclusive.**

TI assumes **no liability for applications assistance, customer product design, software performance, or infringement of patents or services described herein.**

Please read the User's Guide and, specifically, the Warnings and Restrictions notice in the User's Guide prior to handling the product. This notice contains important safety information about temperatures and voltages. For additional information on TI's environmental and/or safety programs, please contact the TI application engineer or visit [www.ti.com/esh](http://www.ti.com/esh).

No license is granted under any patent right or other intellectual property right of TI covering or relating to any machine, process, or combination in which such TI products or services might be or are used.

### FCC Warning

This evaluation board/kit is intended for use for **ENGINEERING DEVELOPMENT, DEMONSTRATION, OR EVALUATION PURPOSES ONLY** and is not considered by TI to be a finished end-product fit for general consumer use. It generates, uses, and can radiate radio frequency energy and has not been tested for compliance with the limits of computing devices pursuant to part 15 of FCC rules, which are designed to provide reasonable protection against radio frequency interference. Operation of this equipment in other environments may cause interference with radio communications, in which case the user at his own expense will be required to take whatever measures may be required to correct this interference.

### EVM WARNINGS AND RESTRICTIONS

It is important to operate this EVM within the input voltage range of 0 V to 5.5 V and the output voltage range of 3 V to 5.5 V.

Exceeding the specified input range may cause unexpected operation and/or irreversible damage to the EVM. If there are questions concerning the input range, please contact a TI field representative prior to connecting the input power.

Applying loads outside of the specified output range may result in unintended operation and/or possible permanent damage to the EVM. Please consult the EVM User's Guide prior to connecting any load to the EVM output. If there is uncertainty as to the load specification, please contact a TI field representative.

During normal operation, some circuit components may have case temperatures greater than +85°C. The EVM is designed to operate properly with certain components above +85°C as long as the input and output ranges are maintained. These components include but are not limited to linear regulators, switching transistors, pass transistors, and current sense resistors. These types of devices can be identified using the EVM schematic located in the EVM User's Guide. When placing measurement probes near these devices during operation, please be aware that these devices may be very warm to the touch.

Mailing Address: Texas Instruments, Post Office Box 655303, Dallas, Texas 75265  
Copyright © 2009, Texas Instruments Incorporated

## IMPORTANT NOTICE

Texas Instruments Incorporated and its subsidiaries (TI) reserve the right to make corrections, modifications, enhancements, improvements, and other changes to its products and services at any time and to discontinue any product or service without notice. Customers should obtain the latest relevant information before placing orders and should verify that such information is current and complete. All products are sold subject to TI's terms and conditions of sale supplied at the time of order acknowledgment.

TI warrants performance of its hardware products to the specifications applicable at the time of sale in accordance with TI's standard warranty. Testing and other quality control techniques are used to the extent TI deems necessary to support this warranty. Except where mandated by government requirements, testing of all parameters of each product is not necessarily performed.

TI assumes no liability for applications assistance or customer product design. Customers are responsible for their products and applications using TI components. To minimize the risks associated with customer products and applications, customers should provide adequate design and operating safeguards.

TI does not warrant or represent that any license, either express or implied, is granted under any TI patent right, copyright, mask work right, or other TI intellectual property right relating to any combination, machine, or process in which TI products or services are used. Information published by TI regarding third-party products or services does not constitute a license from TI to use such products or services or a warranty or endorsement thereof. Use of such information may require a license from a third party under the patents or other intellectual property of the third party, or a license from TI under the patents or other intellectual property of TI.

Reproduction of TI information in TI data books or data sheets is permissible only if reproduction is without alteration and is accompanied by all associated warranties, conditions, limitations, and notices. Reproduction of this information with alteration is an unfair and deceptive business practice. TI is not responsible or liable for such altered documentation. Information of third parties may be subject to additional restrictions.

Resale of TI products or services with statements different from or beyond the parameters stated by TI for that product or service voids all express and any implied warranties for the associated TI product or service and is an unfair and deceptive business practice. TI is not responsible or liable for any such statements.

TI products are not authorized for use in safety-critical applications (such as life support) where a failure of the TI product would reasonably be expected to cause severe personal injury or death, unless officers of the parties have executed an agreement specifically governing such use. Buyers represent that they have all necessary expertise in the safety and regulatory ramifications of their applications, and acknowledge and agree that they are solely responsible for all legal, regulatory and safety-related requirements concerning their products and any use of TI products in such safety-critical applications, notwithstanding any applications-related information or support that may be provided by TI. Further, Buyers must fully indemnify TI and its representatives against any damages arising out of the use of TI products in such safety-critical applications.

TI products are neither designed nor intended for use in military/aerospace applications or environments unless the TI products are specifically designated by TI as military-grade or "enhanced plastic." Only products designated by TI as military-grade meet military specifications. Buyers acknowledge and agree that any such use of TI products which TI has not designated as military-grade is solely at the Buyer's risk, and that they are solely responsible for compliance with all legal and regulatory requirements in connection with such use.

TI products are neither designed nor intended for use in automotive applications or environments unless the specific TI products are designated by TI as compliant with ISO/TS 16949 requirements. Buyers acknowledge and agree that, if they use any non-designated products in automotive applications, TI will not be responsible for any failure to meet such requirements.

Following are URLs where you can obtain information on other Texas Instruments products and application solutions:

### Products

Amplifiers	<a href="http://amplifier.ti.com">amplifier.ti.com</a>
Data Converters	<a href="http://dataconverter.ti.com">dataconverter.ti.com</a>
DLP® Products	<a href="http://www.dlp.com">www.dlp.com</a>
DSP	<a href="http://dsp.ti.com">dsp.ti.com</a>
Clocks and Timers	<a href="http://www.ti.com/clocks">www.ti.com/clocks</a>
Interface	<a href="http://interface.ti.com">interface.ti.com</a>
Logic	<a href="http://logic.ti.com">logic.ti.com</a>
Power Mgmt	<a href="http://power.ti.com">power.ti.com</a>
Microcontrollers	<a href="http://microcontroller.ti.com">microcontroller.ti.com</a>
RFID	<a href="http://www.ti-rfid.com">www.ti-rfid.com</a>
RF/IF and ZigBee® Solutions	<a href="http://www.ti.com/lprf">www.ti.com/lprf</a>

### Applications

Audio	<a href="http://www.ti.com/audio">www.ti.com/audio</a>
Automotive	<a href="http://www.ti.com/automotive">www.ti.com/automotive</a>
Broadband	<a href="http://www.ti.com/broadband">www.ti.com/broadband</a>
Digital Control	<a href="http://www.ti.com/digitalcontrol">www.ti.com/digitalcontrol</a>
Medical	<a href="http://www.ti.com/medical">www.ti.com/medical</a>
Military	<a href="http://www.ti.com/military">www.ti.com/military</a>
Optical Networking	<a href="http://www.ti.com/opticalnetwork">www.ti.com/opticalnetwork</a>
Security	<a href="http://www.ti.com/security">www.ti.com/security</a>
Telephony	<a href="http://www.ti.com/telephony">www.ti.com/telephony</a>
Video & Imaging	<a href="http://www.ti.com/video">www.ti.com/video</a>
Wireless	<a href="http://www.ti.com/wireless">www.ti.com/wireless</a>

Mailing Address: Texas Instruments, Post Office Box 655303, Dallas, Texas 75265  
Copyright © 2009, Texas Instruments Incorporated