

DM537405000NCLF	STRAIGHT MALE COAXIAL CONTACT	1.00	1.75	2.32	3.20	22.40	RG 178 B/U RG 196 A/U
DM537405008NCLF	STRAIGHT MALE COAXIAL CONTACT	1.00	1.75	2.32	3.20	23.60	RG 178 B/U RG 196 A/U
DM537405002NCLF	STRAIGHT MALE COAXIAL CONTACT	2.75	4.00	5.09	5.95	26.30	RG 195 A/U RG 180 B/U
PART NUMBER	DESIGNATION	$\phi A^{+0.10}_0$	$\phi B^{+0.00}_{-0.10}$	$\phi C^{+0.10}_0$	$\phi D^{\pm 0.10}$	(E)	CABLE REF.

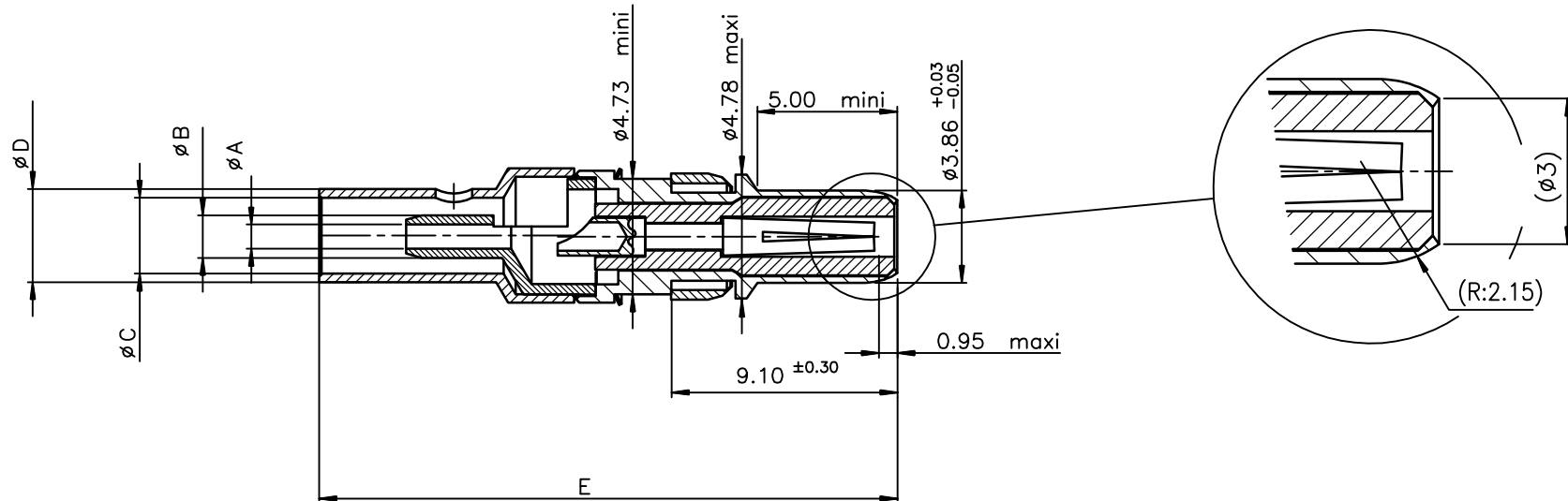

NOTE:RoHS INFORMATIONS

- The "LF" product meets European union Directives and other country regulations as described in GS-22-008.
- The product is not intended to be exposed to a manufacturing solder process.
- Packaging spec: see GS-14-920.

**ELECTRICAL CHARACTERISTICS**

- Impedance: 50 Ohm
- Working frequency: 1GHz max
- Dielectric with standing voltage: 600V
- Insulation resistance 5000: 14 Ohm
- Contact resistance < 5 mOhm
- Insertion lost: < 0.2 dB

**MECHANICAL CHARACTERISTICS**

- Mating force per set of contact 0.4 N to 9 N
- Mating endurance 500
- Temperature -55°C to +125 °C

**TOOLING**

- Coaxial contact extraction tool 8630-07A

rev	ecn no	dr	date
A	LS05-0086	MPE	2005/10/14
B	LS05-0107	MPE	2005/12/20
C	LS06-0101	MPE	2006/06/29
D	LS07-0001	MPE	2007/01/02
E	F10-0086	LSA	2010/08/20
-	-	-	-
-	-	-	-

www.fciconnect.com		surface ISO 1302 ✓	tolerance std ISO 406 ISO 1101	projection A3	mm Scale 5
TOLERANCES UNLESS OTHERWISE SPECIFIED					
Dr	PESSON	2005/10/14	ANGULAR	0.X	±0.1
Eng	PESSON	2005/10/14	LINEAR	0.XX	±0.1
Chr	LEGARE	2005/10/14	0.XX ±2	0.XXX	±0.1
Appr	LEGARE	2005/10/14	Product family		D-SUB
size				ECN F10-0086	
Spec ref				-	
title <b>STRAIGHT MALE COAX CONTACT</b>		dwg no <b>C01-8639-2154</b>		Rev. <b>E</b>	
catalog no		-		CUSTOMER sheet 1 of 1	