

THIS DRAWING IS UNPUBLISHED. RELEASED FOR PUBLICATION  
 © COPYRIGHT - By - ALL RIGHTS RESERVED.

REVISIONS					
P	LTR	DESCRIPTION	DATE	DWN	APVD
	B2	REVISED PER ECO-17-001162	14AUG2017	SK	PO

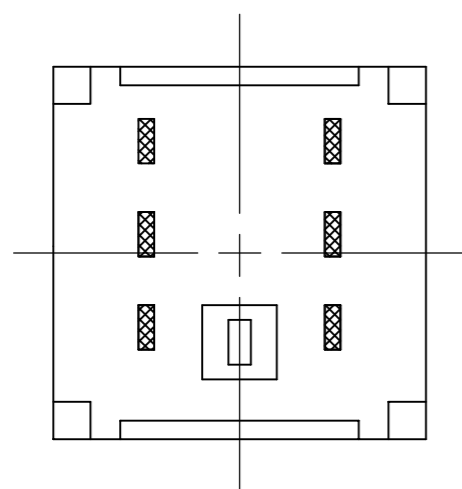
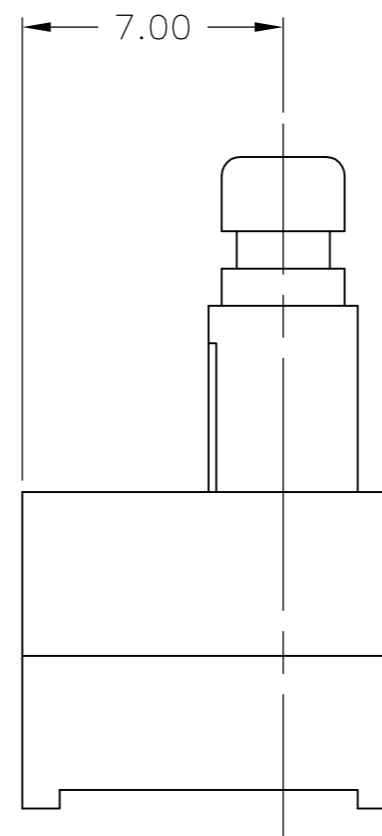
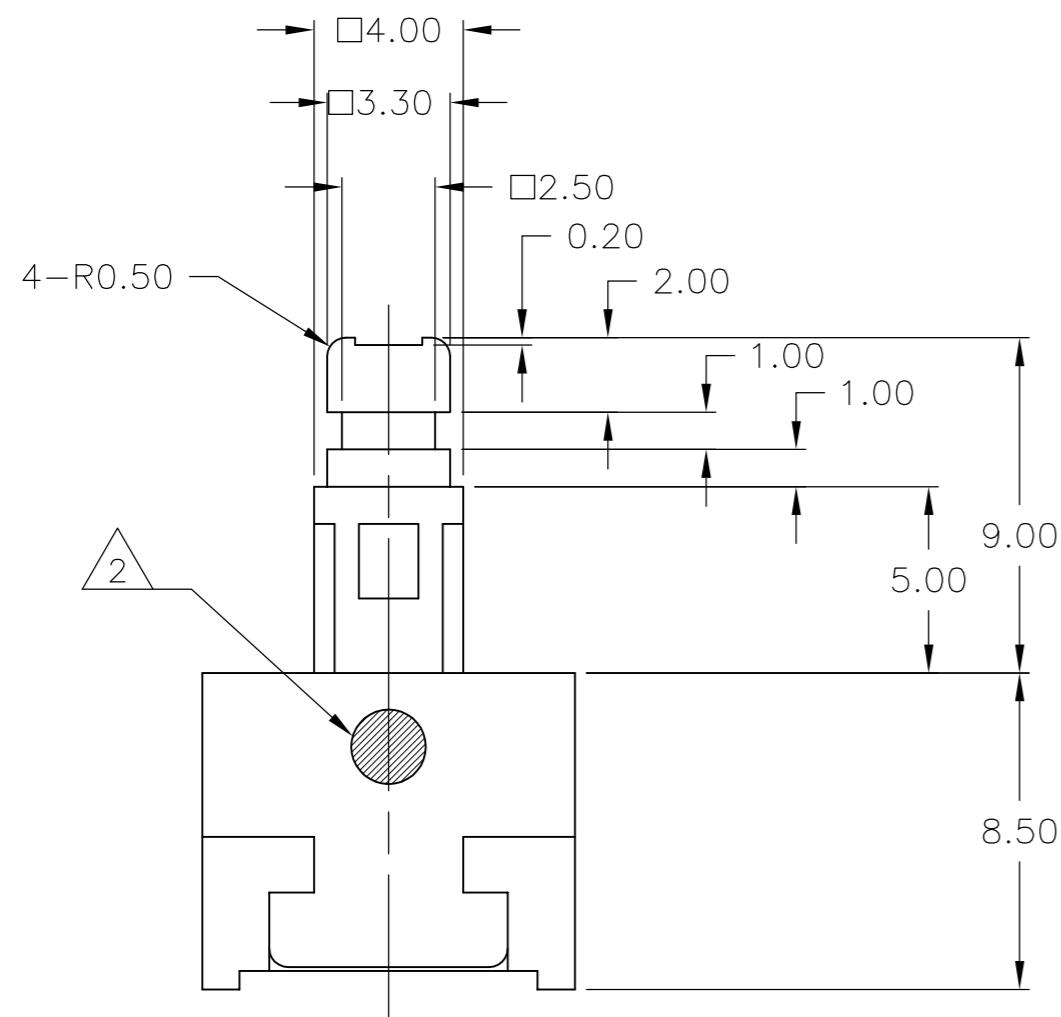
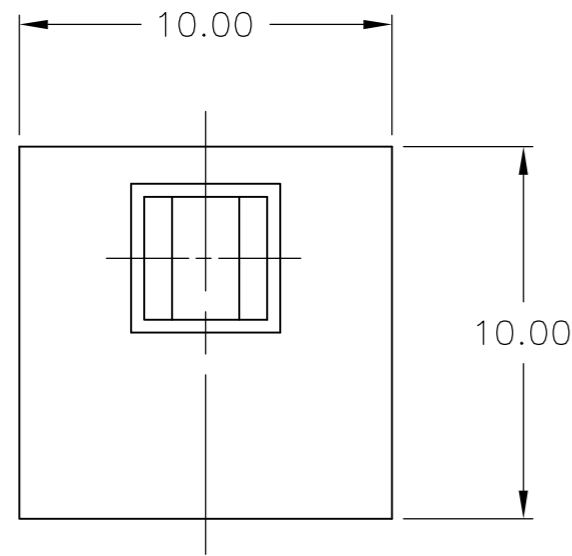

SPECIFICATIONS:

BREAK BEFORE MAKE (NON-SHORTING) CONFIGURATION  
 MAX CONTACT RATING: 100 MILLIAMPS @ 30V DC

OPERATING FORCE: 200±50 GRAMS-FORCE  
 LIFE EXPECTANCY: 100,000 CYCLES

CASE: PBT (UL 95HB) BLACK  
 COVER: NYLON 66 (UL 94HB) BLACK  
 ACTUATOR BUTTON: THERMOPLASTIC (UL 94 HB) BLUE

- 1 100,000 CYCLES ACTUATION FORCE DEVIATION <10% OF ORIGINAL STARTING.
- 2 WHITE PAINT DOT APPROXIMATE SIZE 2.00mm POSITION APPROXIMATE AS SHOWN.

	2	200±50gf	1	SELF LOCK	FULL: 2.5 LOCK: 1.5	BLUE	1825491-3
OBSOLETE		200±50gf	1	SELF LOCK	FULL: 2.5 LOCK: 1.5	BLUE	1825491-1
	MARKING	OPERATING FORCE	OPERATING MODE	TRAVEL	PUSH COLOR	PART NUMBER	

THIS DRAWING IS A CONTROLLED DOCUMENT.		DWN M.BINNER 06JUL2006				
DIMENSIONS: mm		CHK M.WILBOURN 06JUL06				
TOLERANCES UNLESS OTHERWISE SPECIFIED:		APVD M.WILBOURN 06JUL06	NAME SWITCH LATCHING, UNPOPULATED			
0 PLC ± -		PRODUCT SPEC	SIZE A2			
1 PLC ± 0.30		APPLICATION SPEC	CAGE CODE 00779			
2 PLC ± -		WEIGHT	DRAWING NO 1825491			
3 PLC ± -		FINISH	RESTRICTED TO			
4 PLC ± -			SCALE 5:1			
ANGLES ± -			SHEET 1 of 1			
MATERIAL			REV B2			
CUSTOMER DRAWING						