

THIS DRAWING IS UNPUBLISHED. **XXXXXXXXXXXXX** DATE: -
 © COPYRIGHT - BY - ALL RIGHTS RESERVED.

LOC	DIST	REVISIONS			
H	-	LTR	DESCRIPTION	DATE	APVD
		E1	REVISED PER ECO-11-005294	30APR11	HMR

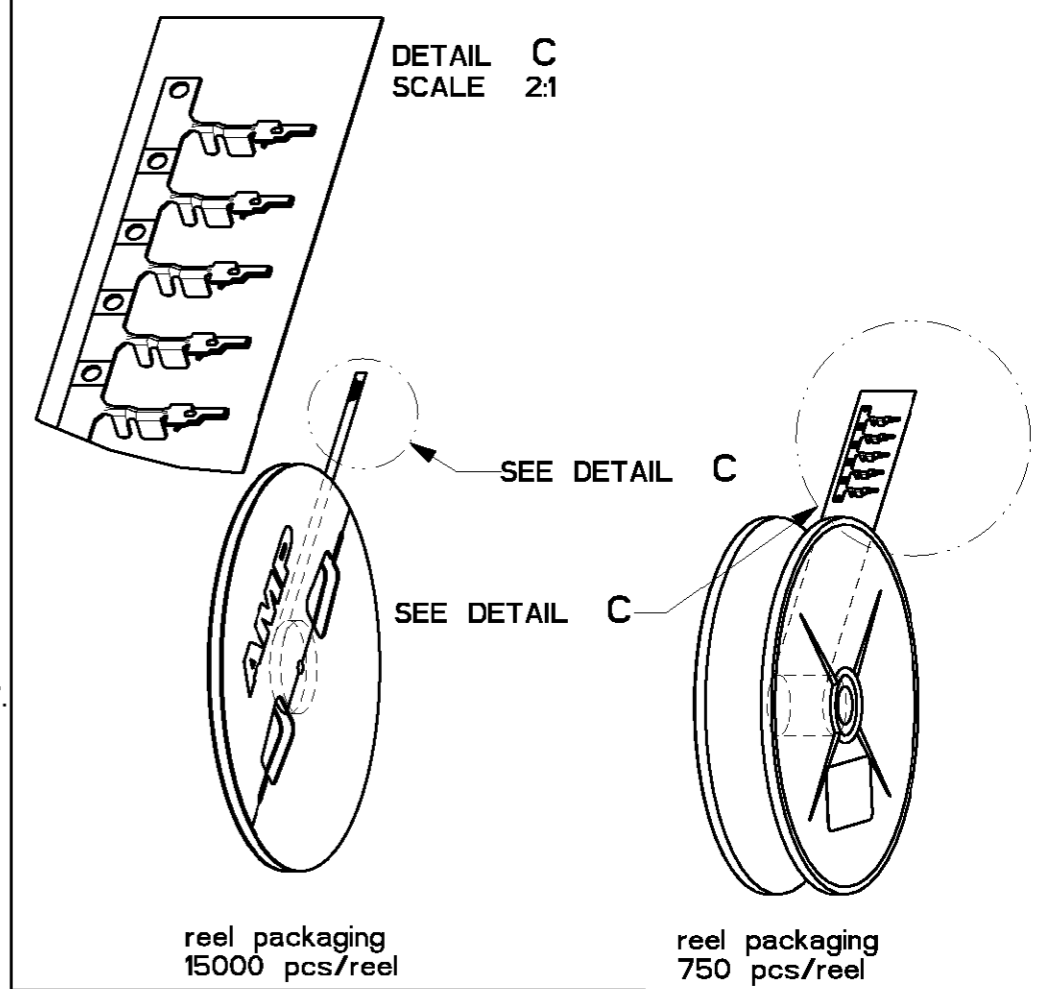

- NOTES:**
1. WIRE RANGE 24-20 AWG
 2. INSULATION RANGE \varnothing .50- .060 (1,27-1,52 mm)
 3. FOR APPLICATOR USE ONLY
 4. FOR HANDTOOL USE ONLY
 5. FOR APPLICABLE CONNECTOR HOUSINGS SEE C-338095.

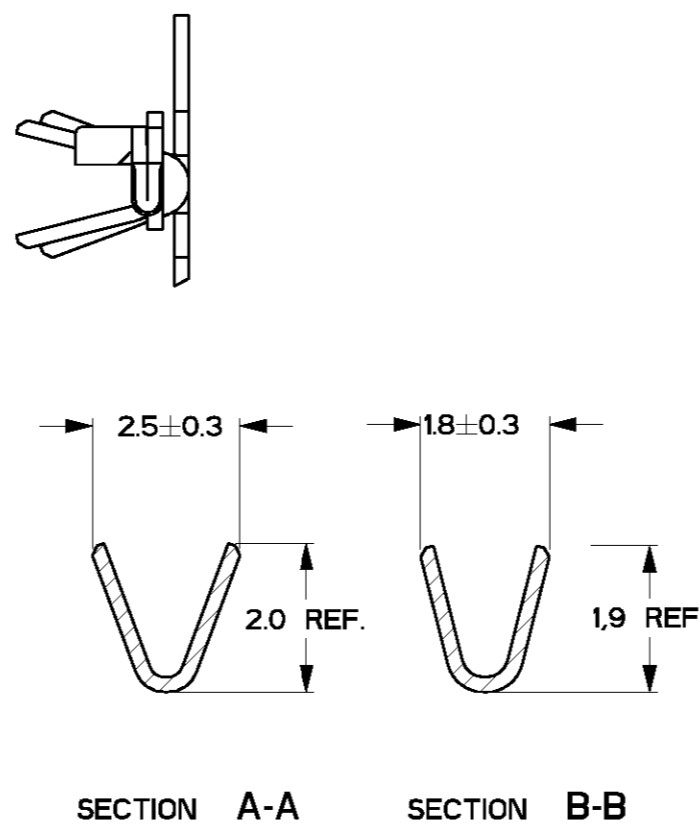
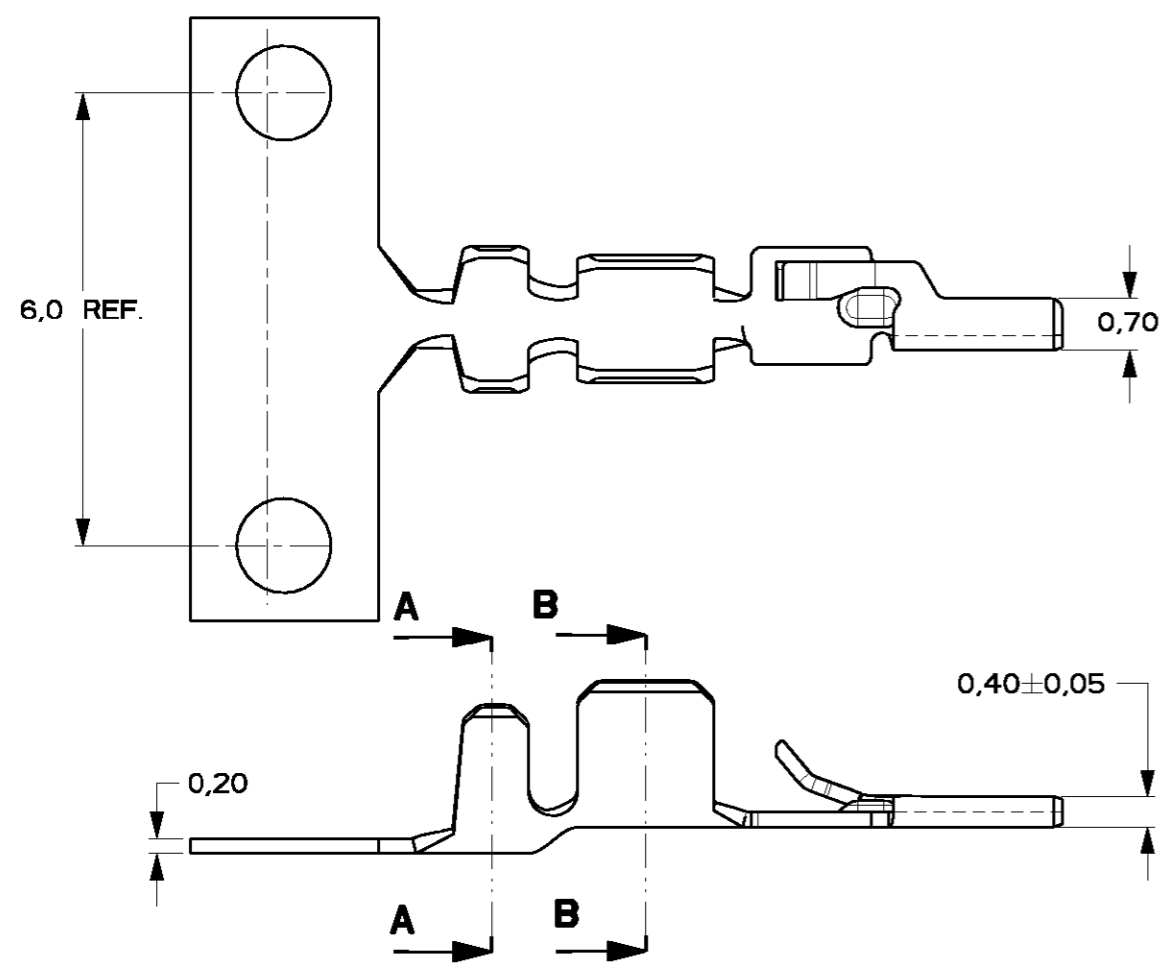
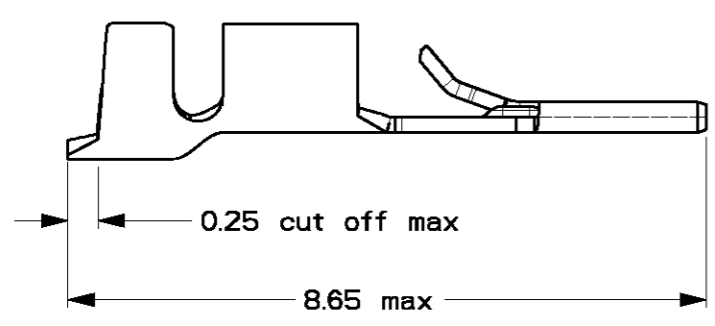
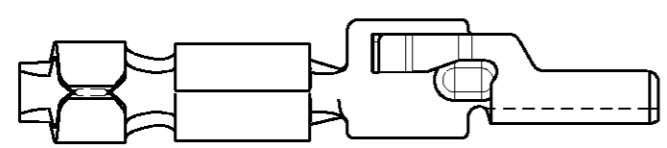

4	750	Pre-Tin	COSI-contact	Phosphorbronze	1-0338097-1
3	15000	Pre-Tin	COSI-contact	Phosphorbronze	0-0338097-1
	Pcs/reel	Finish	Description	Material	Partnumber

DWN M.V.AMELSFORT		 TE Connectivity			
CHK Hv.Delft					
APVD -		NAME MICRO-MATCH COSI CONTACT			
PRODUCT SPEC 108-19052		20-24 AWG			
APPLICATION SPEC 114-19051		SIZE A3	CAGE CODE 00779	DRAWING NO. C-338097	
MATERIAL		WEIGHT -		SCALE 10:1 SHEET 1 OF 1 REV E1	
FINISH Pre-tinplated		CUSTOMER DRAWING			