

RoHS Recast Compliant

M.2 2260 Flash Drive

P200-M Product Specifications

July 8, 2015

Version 1.2



Apacer Technology Inc.

1F, No.32, Zhongcheng Rd., Tucheng Dist., New Taipei City, Taiwan, R.O.C

Tel: +886-2-2267-8000 Fax: +886-2-2267-2261

www.apacer.com

Features:

- **Standard SATA Interface Compliance**
 - Serial ATA Revision 3.1 compliance
 - SATA 6.0 Gbps interface
 - ATA-8 command set
- **Capacities**
 - 16, 32, 64, 128, 256 GB
- **Performance***
 - Interface burst read/write: 600 MB/sec
 - Sustained read: up to 520 MB/sec
 - Sustained write: up to 180 MB/sec
- **Flash Management**
 - Built-in hardware ECC
 - Static/dynamic wear-leveling
 - Flash bad-block management
 - S.M.A.R.T.
 - Power Failure Management
 - ATA Secure Erase
 - TRIM
- **NAND Flash Type: MLC**
- **Endurance**
 - 16GB: 14 TBW
 - 32GB: 28 TBW
 - 64GB: 57 TBW
 - 128GB: 114 TBW
 - 256GB: 228 TBW
- **Temperature ranges**
 - Operating:
 - Standard: 0°C to 70°C
 - Extended: -40°C to 85°C
 - Storage: -40°C to 85°C
- **Supply voltage**
 - 3.3 V \pm 5%
- **Power consumption (typical)***
 - Active mode: 540 mA
 - Idle mode: 105 mA
- **Connector type**
 - 75-pin SATA-based M.2 module pinout
- **Form factor**
 - M.2 2260 form factor
 - Dimensions: 60.00mm x 22.00mm x 3.65mm
- **Shock & Vibration*****
 - Shock: 1500 G
 - Vibration: 15 G
- **MTBF: >2,000,000 hours**
- **RoHS Recast compliant (complies with 2011/65/EU standard)**
- **Device Sleep mode (optional)**

*Varies from capacities. The values for performances and power consumptions presented are typical and may vary depending on flash configurations or platform settings. The term idle refers to the standby state of the device.

***Non-operating

Table of Contents

1. GENERAL DESCRIPTION	3
2. PIN ASSIGNMENTS	3
3. PRODUCT SPECIFICATIONS.....	6
3.1 CAPACITY	6
3.2 PERFORMANCE	6
3.3 ENVIRONMENTAL SPECIFICATIONS	7
3.4 MEAN TIME BETWEEN FAILURES (MTBF)	7
3.5 CERTIFICATION AND COMPLIANCE	7
4. FLASH MANAGEMENT	8
4.1 ERROR CORRECTION/DETECTION	8
4.2 BAD BLOCK MANAGEMENT	8
4.3 WEAR LEVELING	8
4.4 POWER FAILURE MANAGEMENT.....	8
4.5 ATA SECURE ERASE	9
4.6 TRIM	9
4.7 SATA POWER MANAGEMENT	9
4.8 ENDURANCE	10
5. SOFTWARE INTERFACE	11
5.1 COMMAND SET	11
5.2 S.M.A.R.T.....	12
6. ELECTRICAL SPECIFICATION	13
7. MECHANICAL SPECIFICATIONS	14

1. General Description

Apacer's P200-M is the next generation modularized Solid State Drive (SSD) with the shape of all new M.2 form factor, aimed to be the more suitable for mobile and compact computers with standard width at only 22.00 mm. P200-M appears in M.2 2260 mechanical dimensions and is believed to be the leading add-in storage solution for future host computing systems.

The M.2 SSD is designed with SATA-based connector pinouts, providing full compliance with the latest SATA Revision 3.1 interface specifications. Aside from SATA compliance, P200-M delivers exceptional performance and power efficiency. On the other hand, the extreme thin and light form factor makes P200-M the ideal choice for mobile computing systems, which appears to be the trend in near future.

Regarding reliability, P200-M is built with a powerful SATA controller that supports on-the-module ECC as well as efficient wear leveling scheme. In terms of power efficiency, P200-M is compliant with SATA 6.0 Gbps interface standard so that it can operate on SATA power management modes, which greatly save on power consumption.

2. Pin Assignments

This connector does not support hot plug capability. There are a total of 75 pins. 12 pin locations are used for mechanical key locations; this allows such a module to plug into both Key B and Key M connectors.

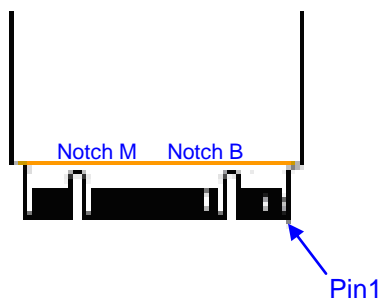

Pin	Type	Description
1	CONFIG_3	Ground (according to M.2 configurations for SSD-SATA definition)
2	3.3V	Supply Pin, 3.3V
3	GND	Ground
4	3.3V	Supply pin, 3.3V
5	No connect	No connect
6	Not available	No connect (used for other purposes)
7	Not available	No connect (used for other purposes)
8	Not available	No connect (used for other purposes)
9	No connect	No connect
10	DAS/DSS	Device Activity Signal/Disable Staggered Spin-up

M.2 2260 Flash Drive APM2T60P200xxxxAN-XTMX

11	No connect	No connect (used for other purposes)
12	Module key	Mechanical notch B
13	Module key	Mechanical notch B
14	Module key	Mechanical notch B
15	Module key	Mechanical notch B
16	Module key	Mechanical notch B
17	Module key	Mechanical notch B
18	Module key	Mechanical notch B
19	Module key	Mechanical notch B
20	Not available	No connect (used for other purposes)
21	CONFIG_0	Ground (according to M.2 configurations for SSD-SATA definition)
22	Not available	No connect (used for other purposes)
23	Not available	No connect (used for other purposes)
24	Not available	No connect (used for other purposes)
25	Not available	No connect (used for other purposes)
26	Not available	No connect (used for other purposes)
27	GND	Ground
28	Not available	No connect (used for other purposes)
29	Not available	No connect
30	Not available	No connect (used for other purposes)
31	Not available	No connect
32	Not available	No connect (used for other purposes)
33	GND	Ground
34	Not available	No connect (used for other purposes)
35	Not available	No connect
36	Not available	No connect (used for other purposes)
37	Not available	No connect
38	Not available	No connect
39	GND	Ground
40	Not available	No connect (used for other purposes)
41	SATA-Rx+	Host receiver differential signal pair
42	Not available	No connect (used for other purposes)
43	SATA-Rx-	Host receiver differential signal pair
44	Not available	No connect (used for other purposes)
45	GND	Ground
46	Not available	No connect (used for other purposes)
47	SATA-Tx-	Host transmitter differential pair

M.2 2260 Flash Drive APM2T60P200xxxxAN-XTMX

48	Not available	No connect (used for other purposes)
49	SATA-Tx+	Host transmitter differential pair
50	Not available	No connect
51	GND	Ground
52	Not available	Not used
53	Not available	Not used
54	Not available	Not used
55	Not available	Not used
56	Reserved for MFG Data	Manufacturing Data line. Used for SSD manufacturing only. Not used in normal operation. Pins should be left N/C in platform Socket.
57	GND	Ground
58	Reserved for MFG clock	Manufacturing Clock line. Used for SSD manufacturing only. Not used in normal operation. Pins should be left N/C in platform Socket
59	Module key	Mechanical notch M
60	Module key	Mechanical notch M
61	Module key	Mechanical notch M
62	Module key	Mechanical notch M
63	Module key	Mechanical notch M
64	Module key	Mechanical notch M
65	Module key	Mechanical notch M
66	Module key	Mechanical notch M
67	Not available	No connect (used for other purposes)
68	SUSCLK	32 kHz clock supply input that is provided by PCH to reduce power and cost for the module
69	CONFIG_1	Defines module type
70	3.3V	Supply pin, 3.3V
71	GND	Ground
72	3.3V	Supply pin, 3.3V
73	GND	Ground
74	3.3V	Supply pin, 3.3V
75	CONFIG_2	Ground

3. Product Specifications

3.1 Capacity

Capacity specification of P200-M is available as shown in Table 3-1. It lists the specific capacity and the default numbers of heads, sectors and cylinders for each product line.

Table 3-1: Capacity specifications

Capacity	Total Bytes	Cylinders	Heads	Sectors	Max LBA
16 GB	16,013,942,784	16,383	16	63	31,277,232
32 GB	32,017,047,552	16,383	16	63	62,533,296
64 GB	64,023,257,088	16,383	16	63	125,045,424
128 GB	128,035,676,160	16,383	16	63	250,069,680
256 GB	256,060,514,304	16,383	16	63	500,118,192

*Display of total bytes varies from file systems, which means not all of the bytes can be used for storage.

**Notes: 1 GB = 1,000,000,000 bytes; 1 sector = 512 bytes.

LBA count addressed in the table above indicates total user storage capacity and will remain the same throughout the lifespan of the device. However, the total usable capacity of the SSD is most likely to be less than the total physical capacity because a small portion of the capacity is reserved for device maintenance usages.

3.2 Performance

Performances of P200-M are listed below in table 3-2.

Table 3-2: Performance

Capacity	16 GB	32 GB	64 GB	128 GB	256 GB
Performance					
Sustained read (MB/s)	300	510	515	520	520
Sustained write (MB/s)	170	180	180	180	180

Note: Results were measured by CrystalDiskMark and may differ from various flash configurations or host system setting

3.3 Environmental Specifications

Environmental specification of P200-M series follows MIL-STD-810 standards as shown in Table 3-3.

Table 3-3 P200-M environmental specifications

Item	Specification
Operating temperature	0°C ~70°C(standard); -40°C ~85°C (extended)
Non-operating temperature	-40°C ~85°C
Operating humidity	40°C, 90%RH
Non-operating humidity	40°C, 93%RH
Vibration (Non-operating)	Frequency/Displacement: 20Hz~80Hz/1.52mm Frequency/Acceleration: 80Hz~2000Hz/20G X, Y, Z axis/60mins
shock (Non-operating)	1500G, 0.5ms
Drop (Non-operating)	80cm free fall, 6 face of each unit
Bending (non-operating)	≥20N, hold 1min/5times
Torque (non-operating)	0.5N-m or ±2.5 deg, hold 1min/5times
ESD (Electrostatic)	Passed (at relative temp/humidity: 24°C, 49%RH)

3.4 Mean Time Between Failures (MTBF)

Mean Time Between Failures (MTBF) is predicted based on reliability data for the individual components in P200-M. The prediction result for P200-M is more than 2,000,000 hours.

Notes about the MTBF:

The MTBF is predicated and calculated based on "Telcordia Technologies Special Report, SR-332, Issue 2" method.

3.5 Certification and Compliance

P200-M complies with the following standards:

- CE: EN55022
- FCC :CISPR22
- BSMI 13438
- RoHS Recast

4. Flash Management

4.1 Error Correction/Detection

P200-M implements a hardware ECC scheme, based on the BCH algorithm. It can detect and correct up to 72 bits error in 1K bytes.

4.2 Bad Block Management

Bad blocks are blocks that include one or more invalid bits, and their reliability is not guaranteed. Blocks that are identified and marked as bad by the manufacturer are referred to as “Initial Bad Blocks”. Bad blocks that are developed during the lifespan of the flash are named “Later Bad Blocks”. Apacer implements an efficient bad block management algorithm to detect the factory-produced bad blocks and manages any bad blocks that appear with use. This practice further prevents data being stored into bad blocks and improves the data reliability.

4.3 Wear Leveling

NAND flash devices can only undergo a limited number of program/erase cycles, and in most cases, the flash media are not used evenly. If some areas get updated more frequently than others, the lifetime of the device would be reduced significantly. Thus, Wear Leveling is applied to extend the lifespan of NAND flash by evenly distributing write and erase cycles across the media.

Apacer provides advanced Wear Leveling algorithm, which can efficiently spread out the flash usage through the whole flash media area. Moreover, by implementing both dynamic and static Wear Leveling algorithms, the life expectancy of the NAND flash is greatly improved.

4.4 Power Failure Management

Power Failure Management is a mechanism to prevent data loss during unexpected power failure. DRAM is a volatile memory and frequently used as temporary cache or buffer between the controller and the NAND flash to improve the SSD performance. However, one major concern of the DRAM is that it is not able to keep data during power failure. Accordingly, P200-M applies the flush mechanism, which requests the controller to transfer data to the cache. For P200-M, DDR performs as a cache. Only when the data is fully committed to the NAND flash will the controller send acknowledgement (ACK) to the host. Such implementation can prevent false-positive performance and the risk of power cycling issues.

Additionally, it is critical for a controller to shorten the time the in-flight data stays in the cache. Thus, P200-M applies an algorithm to reduce the amount of data resides in the cache to provide a better performance. This algorithm allows incoming data to only have a “pit stop” in the cache and then move to the NAND flash at once. If the flash is jammed due to particular file sizes (such as random 4KB data), the cache will be treated as an “organizer”, consolidating incoming data into groups before written into the flash to improve write amplification.

In sum, Power Failure Management proves to provide the reliability required by consumer, industrial, and enterprise-level applications.

4.5 ATA Secure Erase

ATA Secure Erase is a standard ATA command and will write all "0xFF" to fully wipe all the data on hard drives and SSDs. When this command is issued, the SSD controller will empty its storage blocks and return to its factory default settings.

4.6 TRIM

TRIM is a feature which helps improve the read/write performance and speed of solid-state drives (SSD). Unlike hard disk drives (HDD), SSDs are not able to overwrite existing data, so the available space gradually becomes smaller with each use. With the TRIM command, the operating system can inform the SSD which blocks of data are no longer in use and can be removed permanently. Thus, the SSD will perform the erase action, which prevents unused data from occupying blocks all the time.

4.7 SATA Power Management

By complying with SATA 6.0 Gb/s specifications, the SSD supports the following SATA power saving modes:

- ACTIVE: PHY ready, full power, Tx & Rx operational
- PARTIAL: Reduces power, resumes in under 10 μ s (microseconds)
- SLUMBER: Reduces power, resumes in under 10 ms (milliseconds)
- HIPM: Host-Initiated Power Management
- DIPM: Device-Initiated Power Management
- Device Sleep (DevSleep or DEVSLP): PHY powered down; power consumption \leq 5 mW; host assertion time \leq 10 ms; exit timeout from this state \leq 20 ms (unless specified otherwise in SATA Identify Device Log).

Note:

1. The behaviors of power management features would depend on host/device settings.

4.8 Endurance

The endurance of a storage device is predicted by TeraBytes Written based on several factors related to usage, such as the amount of data written into the drive, block management conditions, and daily workload for the drive. Thus, key factors, such as Write Amplifications and the number of P/E cycles, can influence the lifespan of the drive.

Capacity	TeraBytes Written
16 GB	14
32 GB	28
64 GB	57
128 GB	114
256 GB	228

Notes:

- The measurement assumes the data written to the SSD for test is under a typical and constant rate.
- The measurement follows the standard metric: 1 TB (Terabyte) = 1000 GB.
- This estimation complies with JEDEC JESD-219, enterprise endurance workload of random data with payload size distribution.

5. Software Interface

5.1 Command Set

Table 5-1: Command set

Command	Code	Command	Code
Data Set Management	06h	CHECK POWER MODE	98h
Recalibrate	10h-1Fh	SLEEP	99h
Read Sectors	20h	SMART	B0h
Read Sectors without Retry	21h	DEVICE CONFIGURATION	B1h
Read Sectors EXT	24h	Read Multiple	C4h
Read DMA EXT	25h	Write Multiple	C5h
Read Native Max Address EXT	27h	Set Multiple Mode	C6h
Read Multiple EXT	29h	Read DMA	C8h
Read Log EXT	2Fh	Read DMA without Retry	C9h
Write Sectors	30h	Write DMA	CAh
Write Sectors without Retry	31h	Write DMA without Retry	CBh
Write Sectors EXT	34h	Write Multiple FUA EXT	CEh
Write DMA EXT	35h	Standby Immediate	E0h
Set Native Max Address EXT	37h	Idle Immediate	E1h
CFA WRITE SECTORS WITHOUT ERASE	38h	Standby	E2h
Write Multiple EXT	39h	IDLE	E3h
Write DMA FUA EXT	3Dh	Read Buffer	E4h
Write Long EXT	3Fh	Check Power Mode	E5h
Read Verify Sectors	40h	Sleep	E6h
Read Verify Sectors without Retry	41h	Flush Cache	E7h
Read Verify Sectors EXT	42h	Write Buffer	E8h
WRITE UNCORRECTABLE EXT	45h	Flush Cache EXT	EAh
Read FPDMA Queued	60h	Identify Device	ECh
Write FPDMA Queued	61h	Set Features	EFh
Seek	70h-71h	Security Set Password	F1h
Execute Device Diagnostic	90h	Security Unlock	F2h
Initialize Device Parameters	91h	Security Erase Prepare	F3h
Download Microcode	92h	Security Erase Unit	F4h
DOWNLOAD MICROCODE DMA	93h	Security Freeze Lock	F5h
STANDBY IMMEDIATE	94h	Security Disable Password	F6h

M.2 2260 Flash Drive
APM2T60P200xxxxAN-XTMX



IDLE IMMEDIATE	95h	Read Native Max Address	F8
STANDBY	96h	Set Max Address	F9
IDLE	97h		

5.2 S.M.A.R.T.

SMART, an acronym for Self-Monitoring, Analysis and Reporting Technology, is an open standard that allows a hard disk drive to automatically detect its health and report potential failures. When a failure is recorded by SMART, users can choose to replace the drive to prevent unexpected outage or data loss. Moreover, SMART can inform users of impending failures while there is still time to perform proactive actions, such as copy data to another device.

6. Electrical Specification

Table 6-1: Operating range

Ambient Temperature	0°C ~ +70°C(standard) -40°C ~ 85°C (extended)
Supply Voltage	3.3V±5% (3.135-3.465V)

Table 6-2: Typical power consumption

Modes \ Capacity	16 GB	32 GB	64 GB	128 GB	256 GB
Active (mA)	370	480	540	535	535
Idle (mA)	100	100	100	100	105

Note: Results may differ from various flash configurations or host system setting

7. Mechanical Specifications

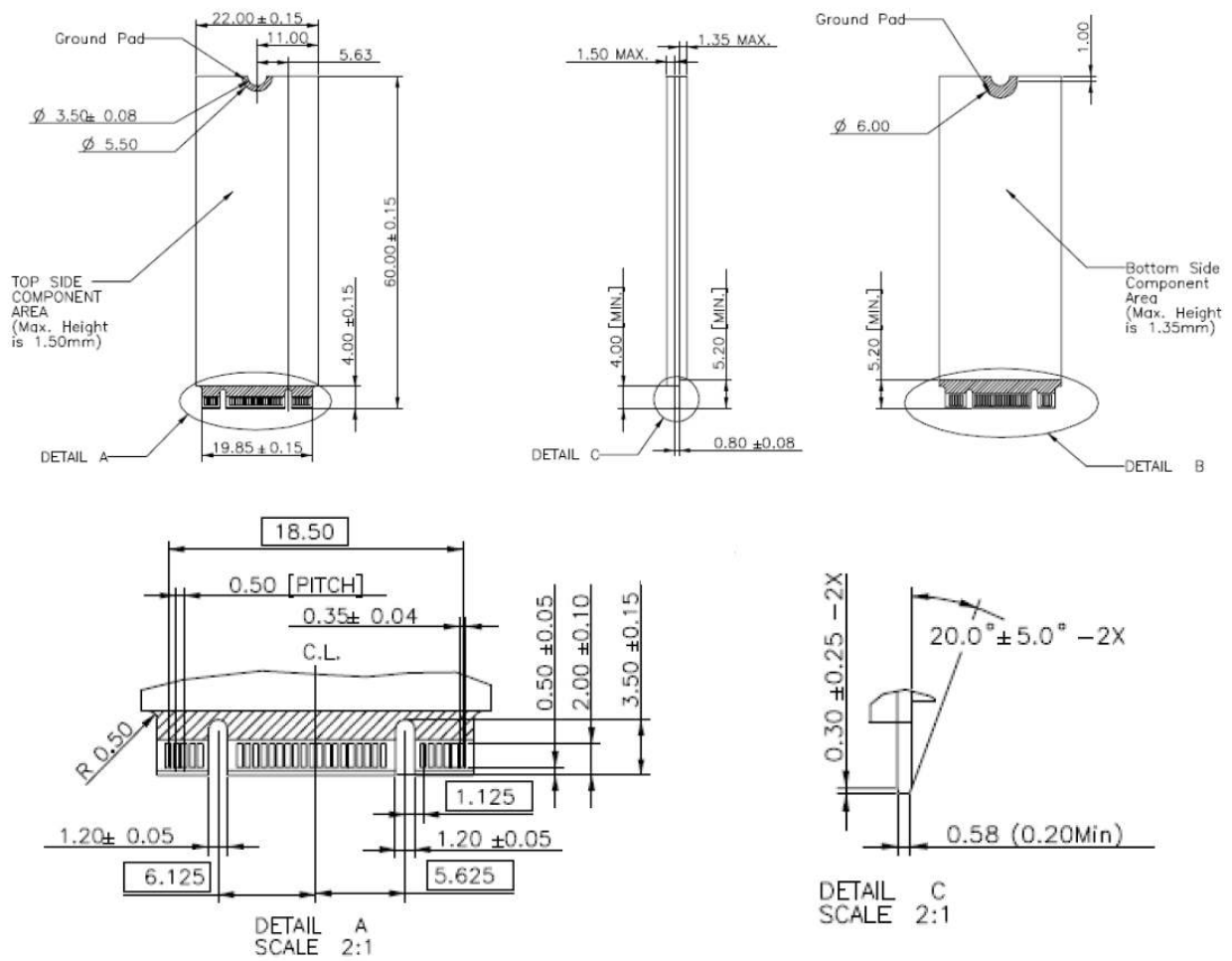

M.2 2260 Flash Drive
APM2T60P200xxxxAN-XTMX

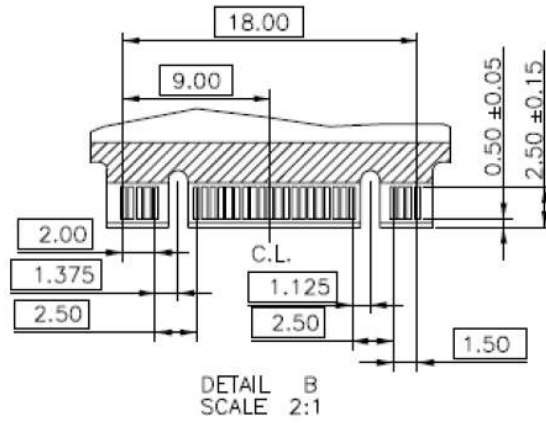

8. Product Ordering Information

8.1 Product Code Designations

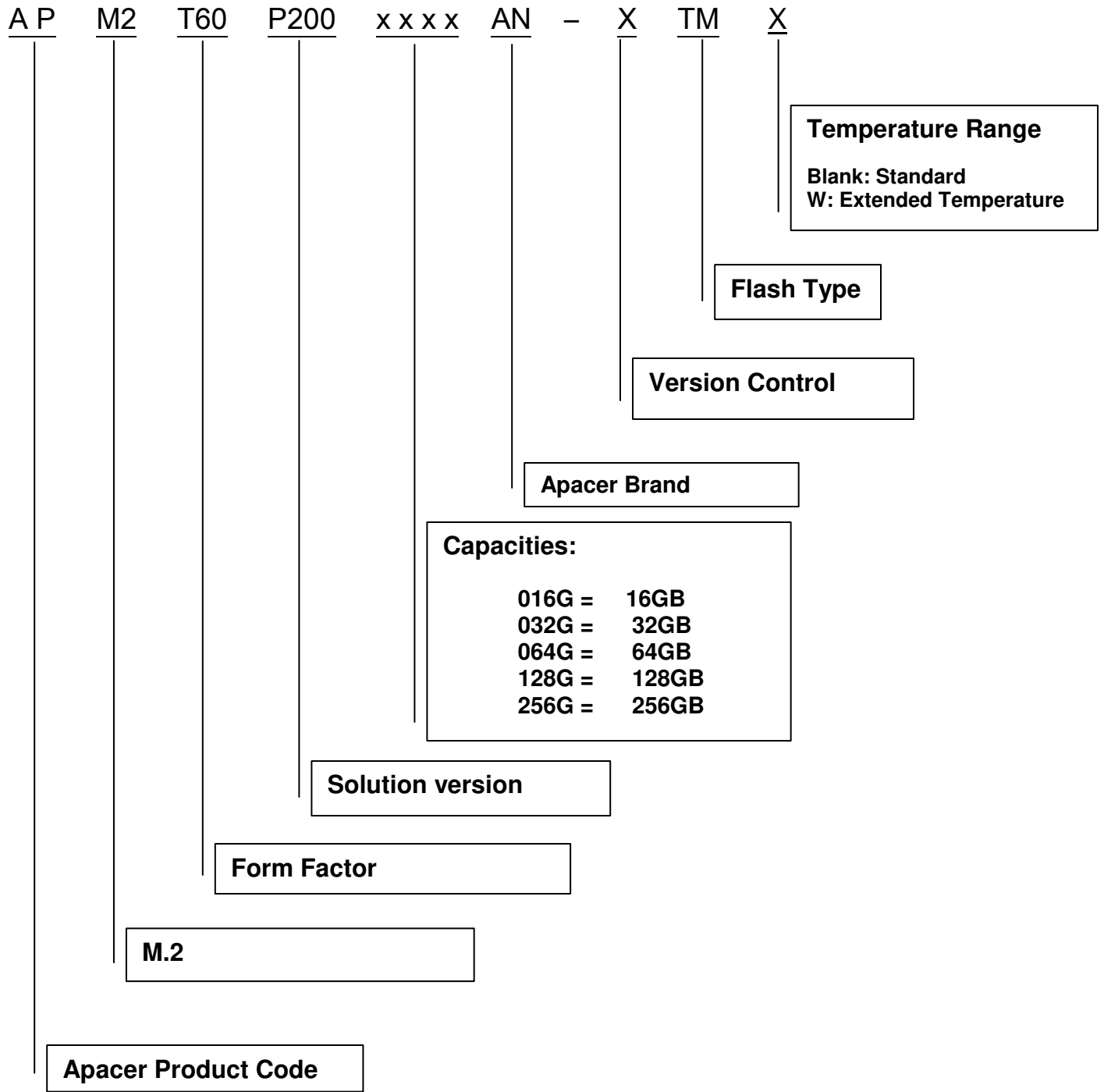

8.2 Valid Combinations

8.2.1 Standard Temperature

Capacity	No DEVSLP	DEVSLP
16GB	APM2T60P200016GAN-7TM	APM2T60P200016GAN-8TM
32GB	APM2T60P200032GAN-7TM	APM2T60P200032GAN-8TM
64GB	APM2T60P200064GAN-7TM	APM2T60P200064GAN-8TM
128GB	APM2T60P200128GAN-7TM	APM2T60P200128GAN-8TM
256GB	APM2T60P200256GAN-7TM	APM2T60P200256GAN-8TM

8.2.2 Extended Temperature

Capacity	No DEVSLP	DEVSLP
16GB	APM2T60P200016GAN-7TMW	APM2T60P200016GAN-8TMW
32GB	APM2T60P200032GAN-7TMW	APM2T60P200032GAN-8TMW
64GB	APM2T60P200064GAN-7TMW	APM2T60P200064GAN-8TMW
128GB	APM2T60P200128GAN-7TMW	APM2T60P200128GAN-8TMW
256GB	APM2T60P200256GAN-7TMW	APM2T60P200256GAN-8TMW

Note: Valid combinations are those products in mass production or will be in mass production. Consult your Apacer sales representative to confirm availability of valid combinations and to determine availability of new combinations.

Revision History

Revision	Date	Description	Remark
1.0	10/28/2014	Official release	
1.1	07/07/2015	Add endurance information	
1.2	07/08/2015	-Added extended temp product support -Revised product ordering information due to FW change(22A)	

Global Presence

Taiwan (Headquarters)	Apacer Technology Inc. 1F., No.32, Zhongcheng Rd., Tucheng Dist., New Taipei City 236, Taiwan R.O.C. Tel: 886-2-2267-8000 Fax: 886-2-2267-2261 amtsales@apacer.com
U.S.A.	Apacer Memory America, Inc. 386 Fairview Way, Suite102, Milpitas, CA 95035 Tel: 1-408-518-8699 Fax: 1-408-935-9611 sa@apacerus.com
Japan	Apacer Technology Corp. 5F, Matsura Bldg., Shiba, Minato-Ku Tokyo, 105-0014, Japan Tel: 81-3-5419-2668 Fax: 81-3-5419-0018 jpservices@apacer.com
Europe	Apacer Technology B.V. Science Park Eindhoven 5051 5692 EB Son, The Netherlands Tel: 31-40-267-0000 Fax: 31-40-267-0000#6199 sales@apacer.nl
China	Apacer Electronic (Shanghai) Co., Ltd 1301, No.251,Xiaomuqiao Road, Shanghai, 200032, China Tel: 86-21-5529-0222 Fax: 86-21-5206-6939 sales@apacer.com.cn
India	Apacer Technologies Pvt Ltd, # 535, 1st Floor, 8th cross, JP Nagar 3rd Phase, Bangalore – 560078, India Tel: 91-80-4152-9061 sales_india@apacer.com