

Interface RF Connector with Switch, 3.9mm High, DC to 6GHz

MS-147 Series

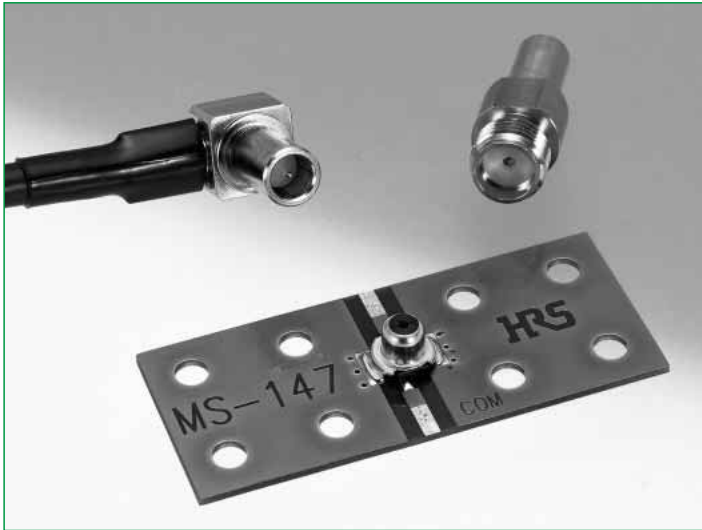

■ Outline

The ultra-small MS-147 coaxial switch series was developed for the portable terminal interface and for inspection of microwave boards (substrates) (DC – 6GHz) used at high frequencies.

To respond to the development of portable terminal technologies and popularization of high-frequency applications – up to 6GHz – this switch features low loss, low profile, and light weight.

The switch circuit is designed so that the NC terminal is connected to the C terminal without a plug mated. Mating with a plug opens this connection.

Vertical mounting structure allows the switch to be placed near the antenna of the portable terminal and used to inspect output and switch to an external antenna.

■ Features

1. Low insertion loss

Insertion loss is as low as:
Typically, 0.08dB at 1GHz
Typically, 0.1dB at 2GHz

2. Space saving

External dimensions are 5.8mm x 5.4mm. Saves installation space.

3. Low profile

Switch height is 3.9mm.

4. Light weight

Switch weight is 0.11g

5. Long life

The switch is guaranteed for up to 12,000 mechanical operations.

6. Auto insertable

Available in embossed tape-and-reel auto-insertable format

7. Wide application range

Operating frequency from DC to 6GHz.

8. RoHS compliant

All components and materials comply with the requirements of the EU Directive 2002/95/EC.

9. Self-alignment

The eccentricity for plug mating is $\pm 0.5\text{mm}$.

■ Application

- * Wireless communication
(Bluetooth, IEEE 802.11)
- * Machines
(Portable terminal, notebook PC, ETC, POS terminal, GPS terminal PDA, etc.)
- * Also suitable for other high-frequency machines.



MS-147(06)



MS-147-C(LP)-1



MS-147-HRMJ-1

Product Specifications

	Not mated with the plug	Mated (MS-147-HRMJ-1)
Operating temperature range	-30°C ~ +85°C	-10°C ~ +65°C
Power rating	4 W	4 W
Frequency range	DC ~ 6 GHz	DC ~ 6 GHz
Insertion loss	0.15dB Max. (DC ~ 2GHz) 0.2dB Max. (2GHz ~ 3GHz) 0.4dB Max. (3GHz ~ 6GHz)	0.2dB max. (DC ~ 2GHz) 0.3dB max. (2GHz ~ 2.5GHz) 0.4dB max. (2.5GHz ~ 3GHz) 0.8dB max. (3GHz ~ 6GHz)
Isolation	25dB min. (DC ~ 1GHz) 20dB min. (1GHz ~ 3GHz) 14dB min. (3GHz ~ 6GHz)	
V.S.W.R.	1.2 Max. (DC ~ 3GHz) 1.5 Max. (3GHz ~ 6GHz)	1.25 max. (DC ~ 2GHz) 1.3 max. (2GHz ~ 2.5GHz) 1.4 max. (2.5GHz ~ 3GHz) 1.9 max. (3GHz ~ 6GHz)

Item	Standard	Conditions
1.Contact resistance	Center 75m ohms max. Outer 50m ohms max.	100mA max.
2.Insulation resistance	1,000M ohms or more	100V DC
3.Withstanding voltage	No flashover or insulation breakdown	100V AC / one minute
4. Vibration	No electrical discontinuity for 10 μ s Min.	Frequency of 10 to 55 Hz, overall amplitude of 1.5 mm for 2 hours in each of 3 directions
5. Shock		Acceleration of 490 m/s ² , sine half-wave waveform, 3 cycles in each of the 3 axis
6.Humidity	Contact resistance: Center 100m ohms max. Outer 75m ohms max. Insulation resistance 10M ohms min.	96 hours at temperature of 40°C and humidity of 90% to 95%
7.Temperature cycle		Temperature : -55°C → +15°C → +35°C → 85°C → +15°C → +35°C Time:30 →5 max. → 30 → 5 max. 100 cycles
8.Salt spray	Contact resistance: Center 100m ohms max. Outer 75m ohms max. No excessive corrosion	Exposed to 5% salt water solution for 48 hours(at +35°C)
9.Durability (Insertion/withdrawal)	Contact resistance: Center 100m ohms max. Outer 75m ohms max.	12,000 cycles

Materials

Part	Material	Finish	Remarks
Shell	Phosphor bronze	Gold plating	—————
Insulator	Polyamide resin	—————	UL94HB
Common terminal	Beryllium copper	Gold plating	—————
Board circuit side (N.C) terminal	Beryllium copper	Gold plating	—————

Typical Data

● NORMALLY CLOSED (N.C)~ (Not mated with the plug)

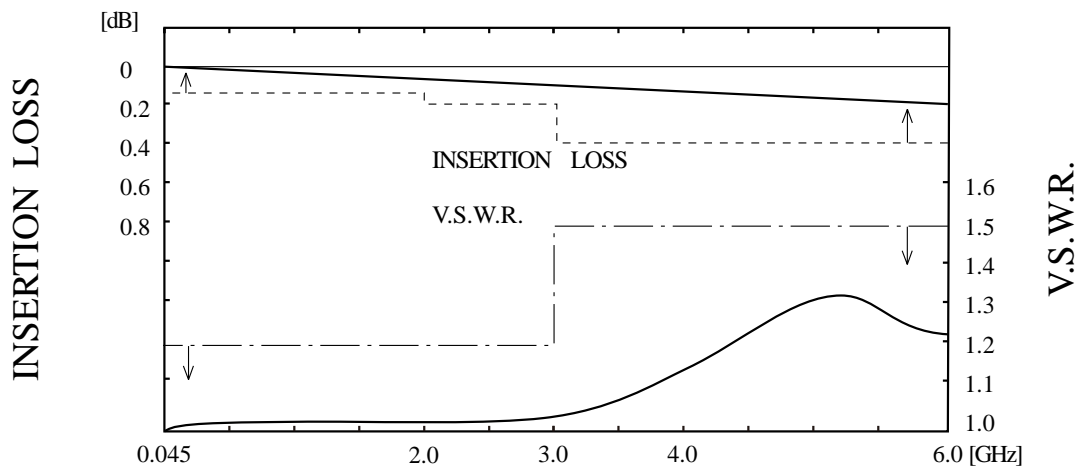

● OPEN (N.O)~ (Mated with the plug)

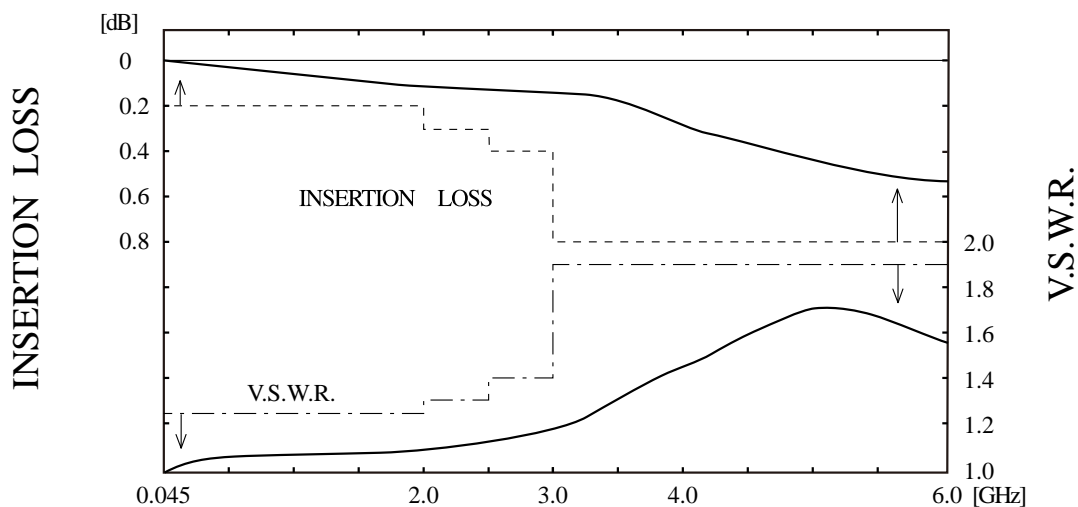

● ISOLATION

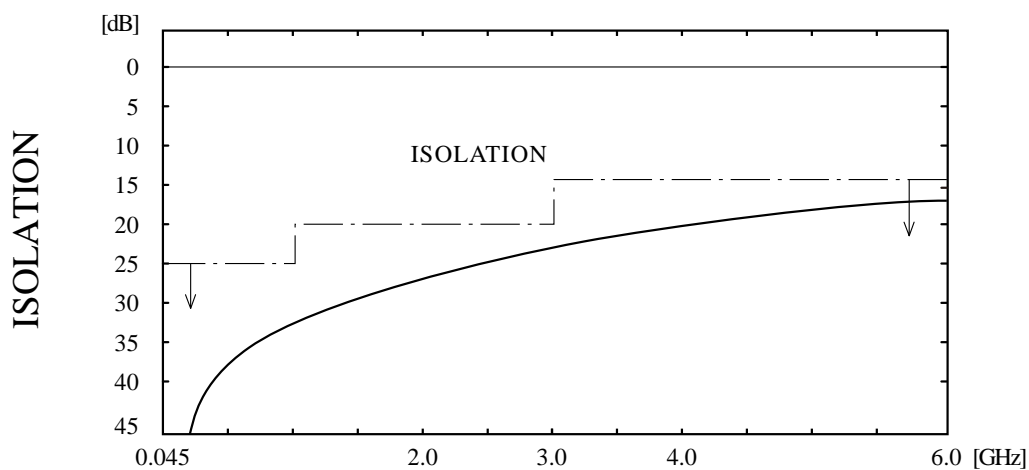

Receptacle

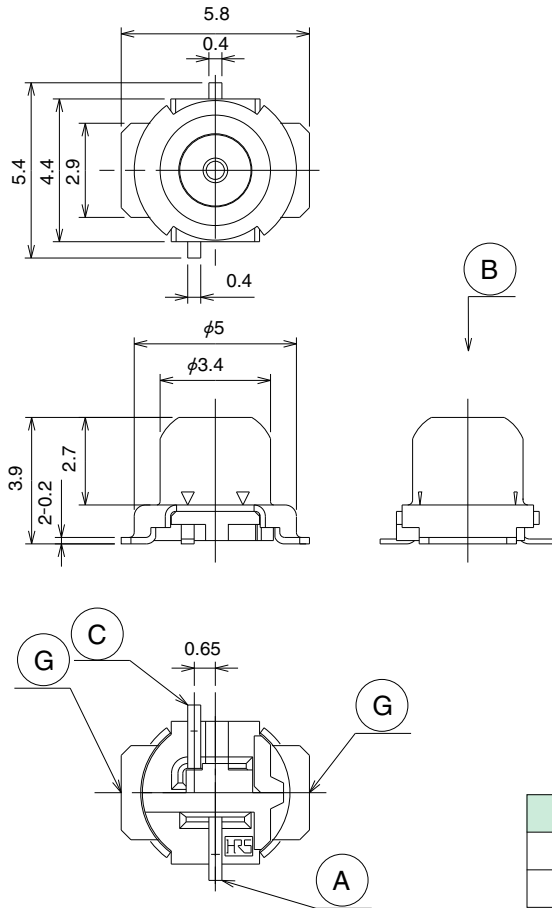

Circuit diagram

Not mated with the plug
(N.C)

Mated with the plug
(N.O)

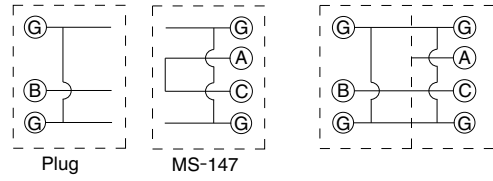

Part Number	HRS No.	Packaging	RoHS
MS-147(06)	CL358-0150-5-06	1,500 pieces / reel	YES
MS-147(01)	CL358-0150-5-01	50 pieces	

Embossed Carrier Tape Dimensions

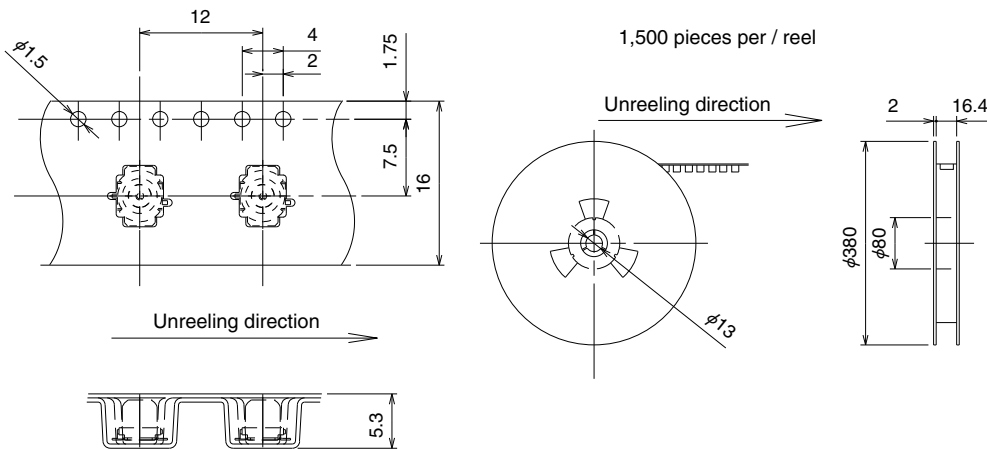

◆PCB Mounting pattern

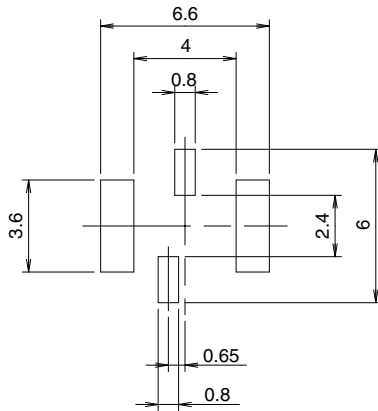

◆Metal mask dimensions

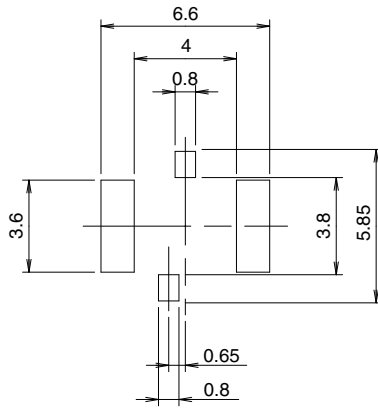

■Plug

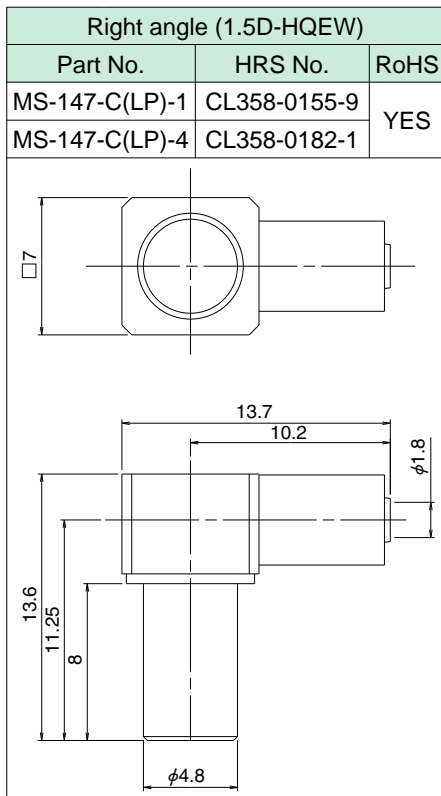

■SMA Conersion Adapters

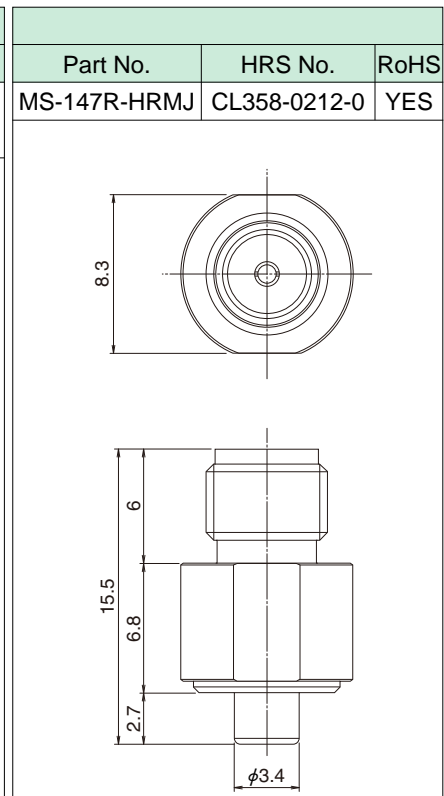
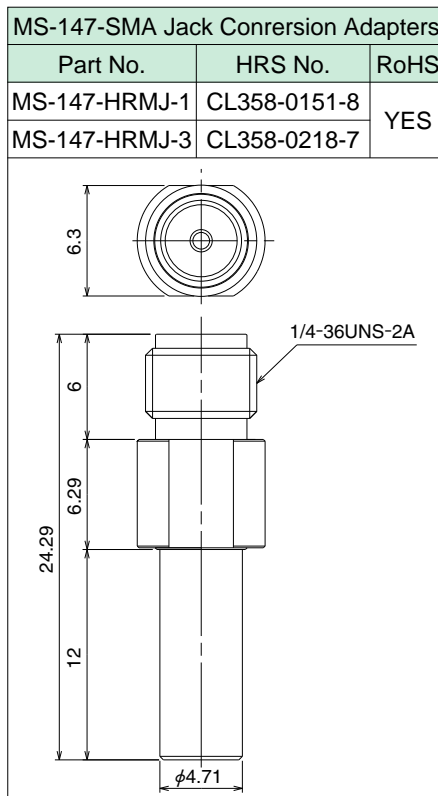

Jun.1.2023 Copyright 2023 HIROSE ELECTRIC CO., LTD. All Rights Reserved.

◆ Recommended Temperature Profile

● Using Typical Solder Paste

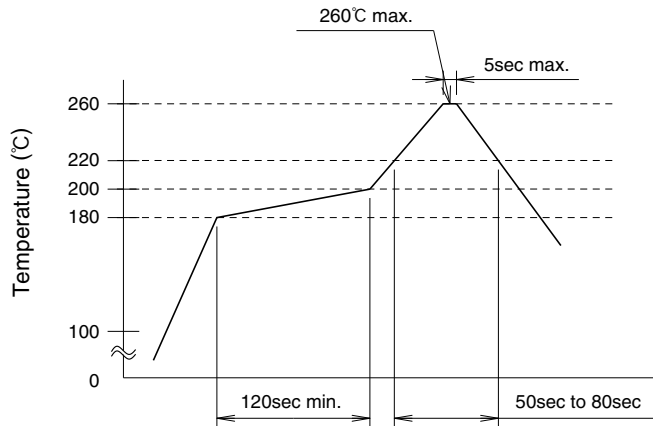

① Max. temperature	: 260°C
② Duration of peak temperature	: 5sec max.
③ Base peak temperature	: 240°C ~ 255°C
④ 220°C or over	: 50sec to 80sec.
⑤ 180°C to 200°C	: 60sec to 120sec.

◆ Example of Application

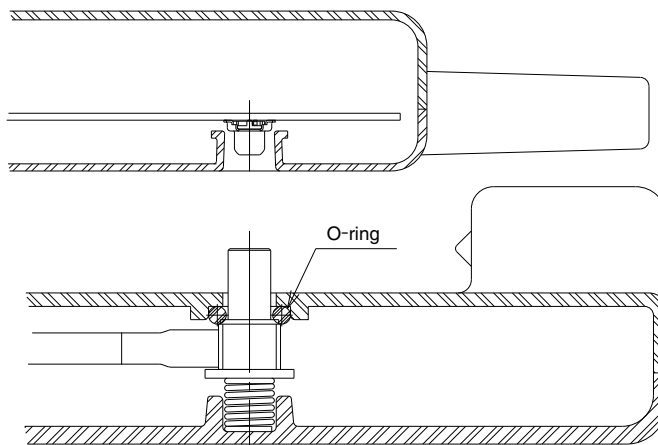

Note: Mounting example

Recommended Nozzle Dimensions

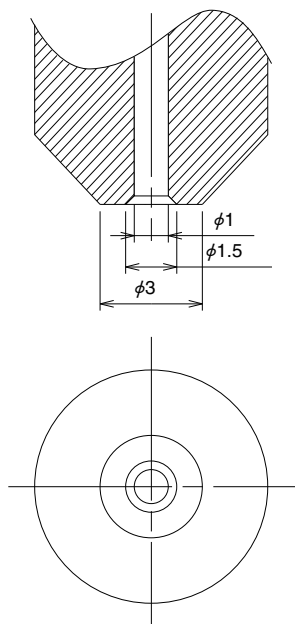

Precautions

1. Plugs

Part No.	Use	Effective mating length
MS-147-C(LP)-1	Plug harness type	0.87mm
MS-147-C(LP)-4	Plug harness type	0.87mm
MS-147-HRMJ-1	SMA conversion adapter	0.87mm
MS-147-HRMJ-3	SMA conversion adapter	0.87mm

2. Not washable.

3. Design the mounting holes with sufficient clearance to protect the switch from being subjected to excessive force should the board be dropped.

4. For RF interface application for portable terminals, cover the plug entry with a rubber cap to keep dust out when no plug is inserted.

5. Be sure to fully insert the plug until it contacts part P.

