



# 285 MHz Bandpass Filter

## Part Number: AE258B9875



### Electrical Specifications

**Center Frequency:** 258 MHz  
**Bandwidth:** 27.5 MHz  
**Passband:** 243-270.5 MHz  
**Insertion Loss:** 2.0 dB Max  
**Return Loss:** 14 dB Min  
**Rejection:** >50 dB @ 0-200 MHz  
>45 dB @ 320-1100 MHz

### Mechanical

**Connector Type:** SMA (F)  
**Dimensions:** 1.25 x 0.375 x 0.375 Inches

### Environmental

**Operating Temperature:** -30 to +75° C  
**Storage Temperature:** -40 to +85° C

### Outline Drawing:

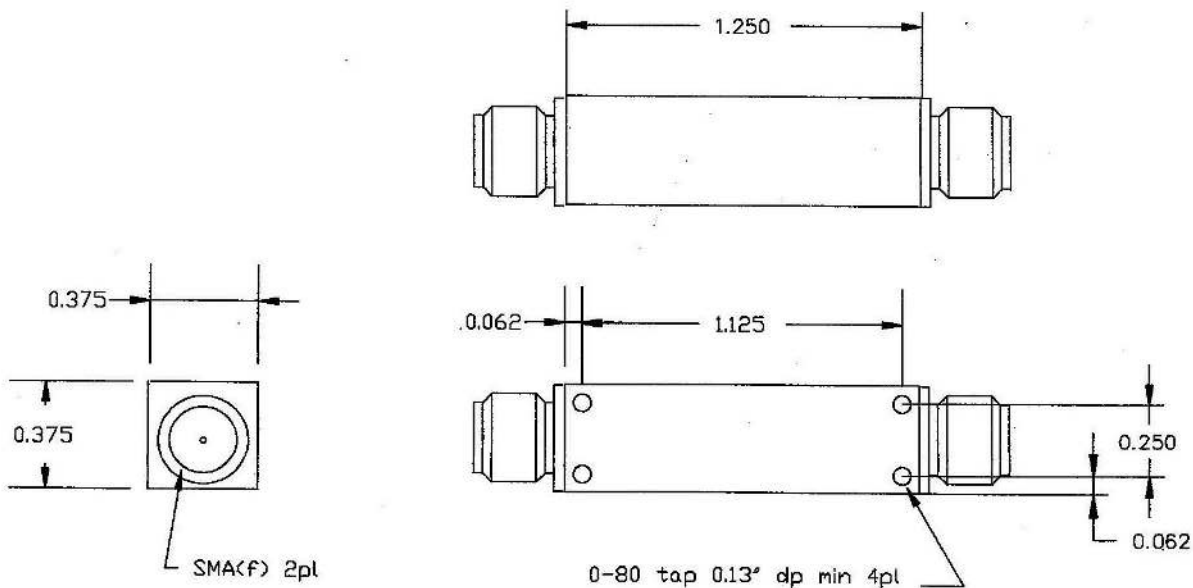



# 285 MHz Bandpass Filter

## Part Number: AE258B9875



### Response Plot:

