

Transfer or duplication of this document as well as the utilisation or communication of its content are not permitted unless express consent is granted. Violations give rise to claims for damages. All rights reserved in case of patent, utility model or design patent registrations.

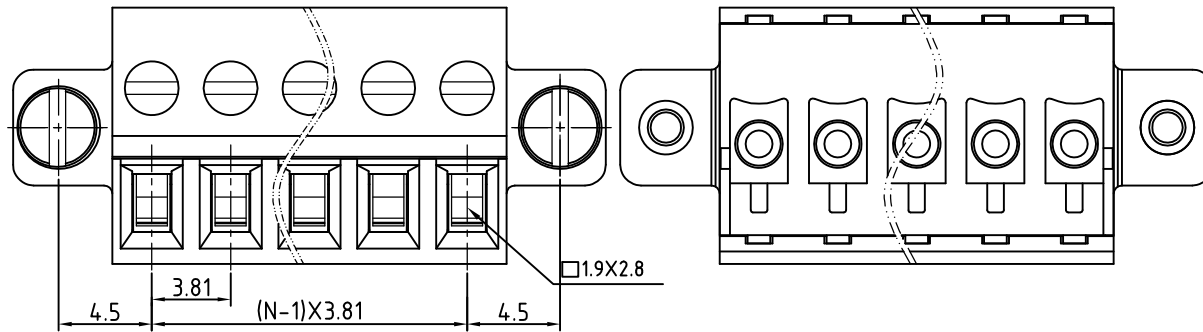

N=Number of contacts

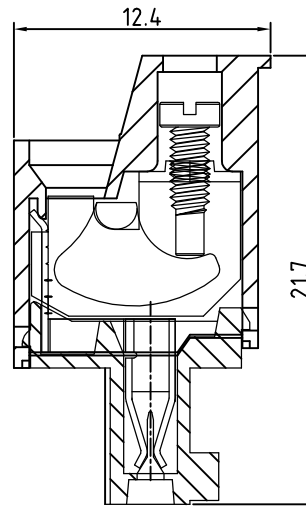
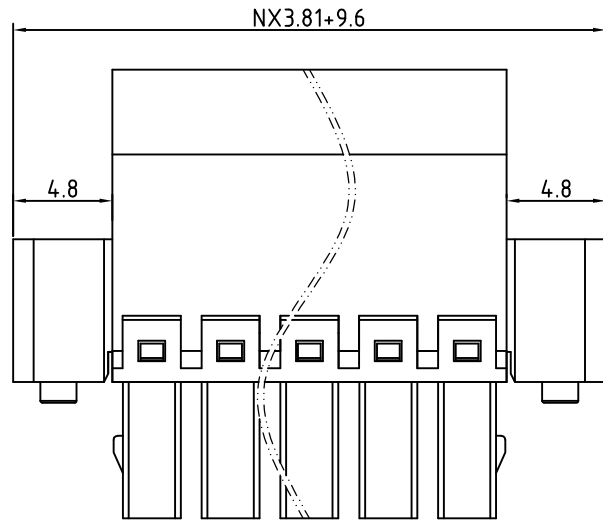

Technical Data:

Electrical

- Pitch: 3.81mm
- Voltage rating: 300V
- Current rating: 12 Amps
- Contact resistance: 20mΩ(max)
- Withstanding Voltage: 2500VAC(1min) Test time=60sec/1pcs
- Wire Range:12-24AWG
- Wire strip length: 6-7mm

Mechanical:

- Torque: 2.5kgf.cm/M2
- Operating temperature: -40°C to +105°C
- Safety approval:
- RoHS Compliance

Part No.:

OSTVMXX3552

<p>No. of Poles</p> <p>02 2 Poles</p> <p>03 3 Poles</p> <p>... ..</p> <p>24 24 Poles</p> <p>Nonstandard colors Mins could apply</p>	<p>COLOR</p> <p>0: Black</p> <p>2: Red</p> <p>3: Orange</p> <p>4: Yellow</p> <p>5: Green (Standard)</p> <p>6: Blue</p> <p>8: Grey</p>
---	---

7	Flange with screw	Steel / M2.5	Cr3+ plated	2
6	Contact	Copper Alloy	Cr3+ plated	1xN
5	Axe	Copper Alloy	Cr3+ plated	1xN
4	Screw	Steel / M2.0	Cr3+ plated	1xN
3	Wire guard	Copper Alloy	Tin plated	1xN
2	Cover	PA66 UL94V-0		1
1	Body	PA66 UL94V-0		1

ITEM	NAME OF PART	MATERIAL	NOTES	Q'TY
DWG.	DATE	UNITS:	MM	SHEET: 1 OF 1
CHK.	DATE	SCALE:	NONE 4:1 (:)	REV.: A
APP.	DATE	TITLE:	OSTVM SERIES 3.81MM WITH FLANGE	
		PART NO.	OSTVMXX3552	
		DWG NO.	OSTVMXX3552.DWG	

REV	△	SIGN	DESCRIPTION	CHK.	DATE

OST
ON-SHORE TECHNOLOGY, INC.