

DRAWING MADE IN THIRD ANGLE PROJECTION

THIS DRAWING IS UNPUBLISHED. RELEASED FOR PUBLICATION .19
 © COPYRIGHT 19 BY TE INCORPORATED. ALL INTERNATIONAL RIGHTS RESERVED.

LOC	DIST	P	F	REVISIONS				
				ZONE	LTR	DESCRIPTION	DATE	APPD
AF	50				H4	REVISED PER ECR-18-006427	14MAY2018	BW/SV

- 1 CONTINUOUS STRIP ON REELS WITH TERMINALS LOCATED ON 5.59 ± 0.08 $[\.220 \pm .003]$ CENTERS.
- 2 SLOT ACCEPTS 0.36-0.57 mm [#27-#23] AWG COPPER MAGNET WIRE.
SLOT ACCEPTS 0.51-0.64mm [#24-#22] ALUMINUM MAGNET WIRE.
ALUMINUM WIRE RANGE APPLIES FOR POST-TIN PLATED VERSIONS ONLY.
- 3 MATES WITH STANDARD MAG-MATE STYLED POKE-IN TAB TERMINAL.
- 4 TIN PLATE

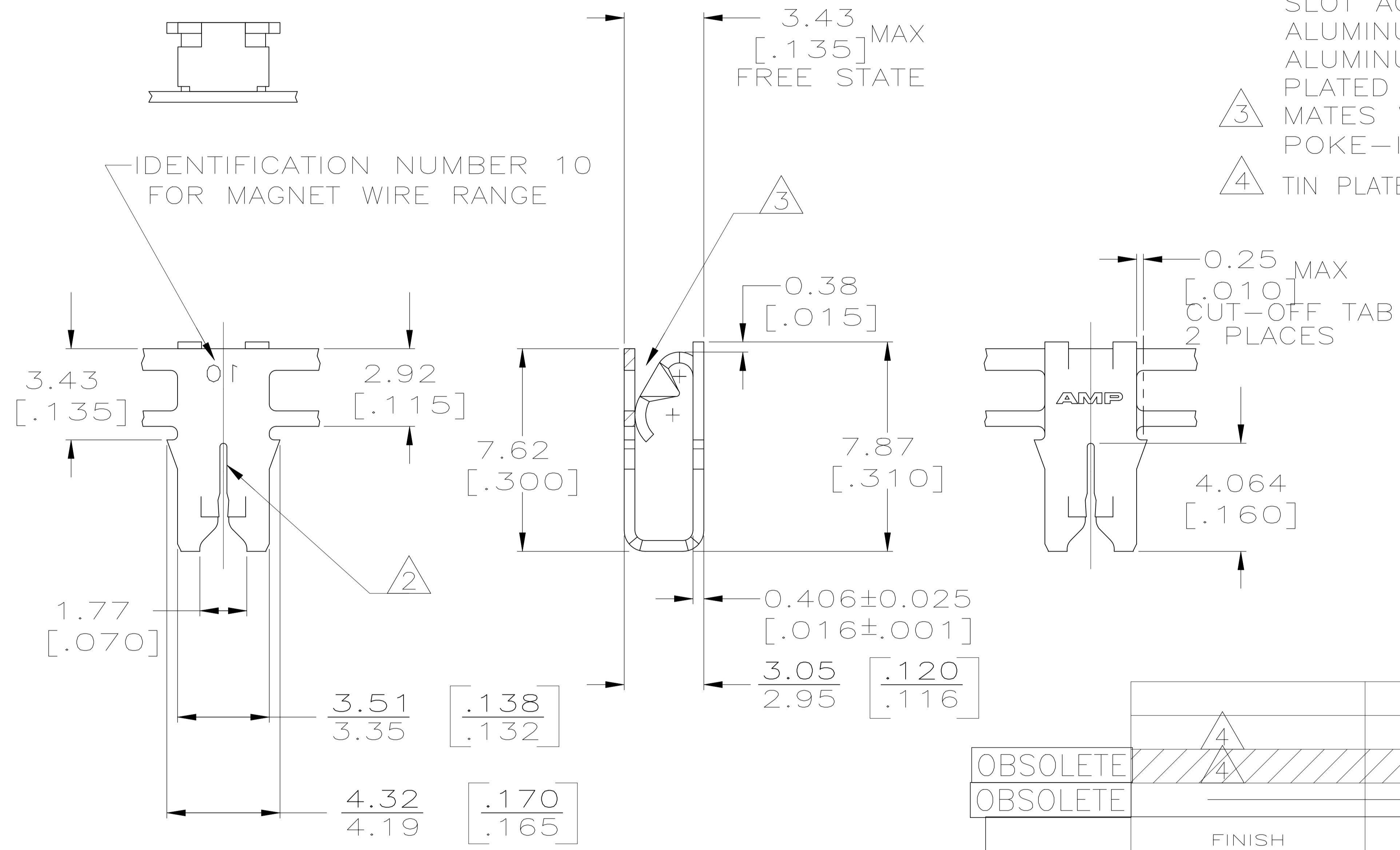

FINISH	MATERIAL	PART NO
	H04 PHOS. BRONZE	1-63551-3
		63551-3
OBSOLETE	4M BRASS	63551-2
OBSOLETE	4M BRASS	63551-1

DO NOT SCALE PRINT. UNLESS SPECIFIED	DR 8/21/89
DIMENSIONS IN mm [INCHES]	CHK 8/23/89
TOLERANCES ON:	APPD 8/23/89
2 PLC DEC \pm -	DF DECKER
3 PLC DEC \pm 0.25 [.010]	APPD 8/23/89
ANGLES \pm -	TL SHUTTER
MATERIAL	PRODUCT SPEC
SEE TABLE	108-2012
FINISH	APPLICATION SPEC
SEE TABLE	114-2046
	WEIGHT

TE TE Connectivity

NAME: SPECIAL LEAF CONTACT, 300 SERIES MAG-MATE™

SIZE	CAGE CODE	DRAWING NO
B	00779	63551
SCALE	SHEET	REV.
5:1	1 OF 1	H4

CUSTOMER DRAWING