

SD3114

Low profile metalized shielded drum core power inductors

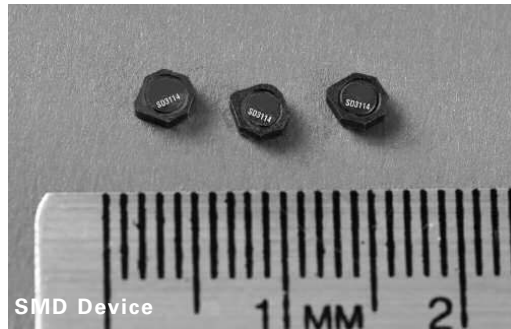

Product features

- 3.1 mm x 3.1 mm x 1.4 mm shielded drum core
- Ferrite core material
- Inductance range from 1.0 uH to 330 uH
- Current range from 2.59 A to 0.106 A
- Frequency range up to 4 MHz

Applications

- Mobile phones,
- Digital cameras
- Media players
- Small LCD displays
- LED driver and LED flash circuits
- Hard disk drives
- LCD Backlighting

Environmental data

- Storage temperature range (component):
-40 °C to +125 °C
- Operating temperature range: -40 °C to +125 °C
(ambient plus self-temperature rise)
- Solder reflow temperature:
J-STD-020 (latest revision) compliant



Product specifications

Part Number	Rated Inductance (μH)	OCL (1) (μH)	Part Marking Designator	I _{rms} (2) (A)	I _{sat} (3) (A)	DCR (Ω) typ. @ +20 °C	K-factor (4)
SD3114-1R0-R	1.0	1.16+/-30%	A	1.60	2.35	0.058	98
SD3114-1R5-R	1.5	1.44+/-30%	B	1.39	2.11	0.077	79
SD3114-2R2-R	2.2	2.12+/-30%	C	1.17	1.74	0.110	67
SD3114-3R3-R	3.3	3.36+/-30%	D	0.95	1.38	0.167	54
SD3114-4R7-R	4.7	4.90+/-30%	E	0.77	1.14	0.251	45
SD3114-6R8-R	6.8	6.72+/-30%	F	0.71	0.98	0.296	37
SD3114-8R2-R	8.2	8.10+/-30%	G	0.68	0.89	0.329	34
SD3114-100-R	10.0	10.4+/-30%	H	0.57	0.78	0.458	30
SD3114-150-R	15.0	14.9+/-20%	I	0.48	0.66	0.650	25
SD3114-220-R	22.0	22.5+/-20%	J	0.43	0.53	0.821	21
SD3114-330-R	33.0	33.1+/-20%	K	0.35	0.44	1.23	17
SD3114-470-R	47.0	47.5+/-20%	L	0.280	0.37	1.86	14
SD3114-680-R	68.0	68.6+/-20%	M	0.239	0.305	2.62	12
SD3114-820-R	82.0	81.8+/-20%	N	0.227	0.280	2.91	11
SD3114-101-R	100.0	101.1+/-20%	O	0.213	0.252	3.30	10
SD3114-151-R	150.0	149.0+/-20%	P	0.172	0.207	5.07	8
SD3114-221-R	220.0	220.9+/-20%	Q	0.140	0.170	7.67	6
SD3114-331-R	330.0	329.5+/-20%	R	0.113	0.139	11.78	5

(1) Open Circuit Inductance Test Parameters: 100 kHz, 0.1V_{rms}, 0.0 Adc.
 (2) I_{rms}: DC current for an approximate DT of 40 °C without core loss. Derating is necessary for AC currents. PCB layout, trace thickness and width, air-flow, and proximity of other heat generating components will affect the temperature rise. It is recommended that the temperature of the part not exceed +125 °C under worst case operating conditions verified in the end application.

(3) I_{sat} Amperes peak for approximately 30% rolloff (@ +20 °C)
 (4) K-factor: Used to determine B_{p-p} for core loss (see graph).
 $B_{p-p} = K * L * \Delta I$, B_{p-p}(mT), K: (K factor from table), L: (Inductance in uH), Δ(Peak to peak ripple current in Amps).

Dimensions- mm

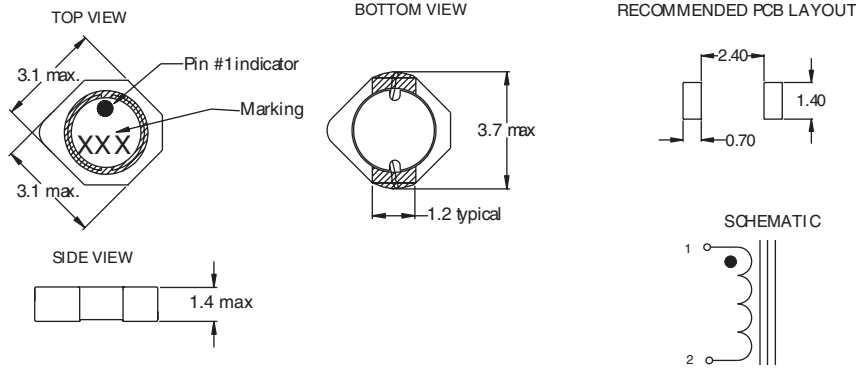

Part Marking:
 3 Digit Marking: (1st digit: Indicates inductance value per letter in Part Marking Designator); (2nd digit: Bi-weekly production date code); (3rd digit: Last digit of the year produced).
 Do not route traces or vias underneath the inductor

Packaging information- mm

Parts packaged on 13" Diameter reel,
 4,100 parts per reel.

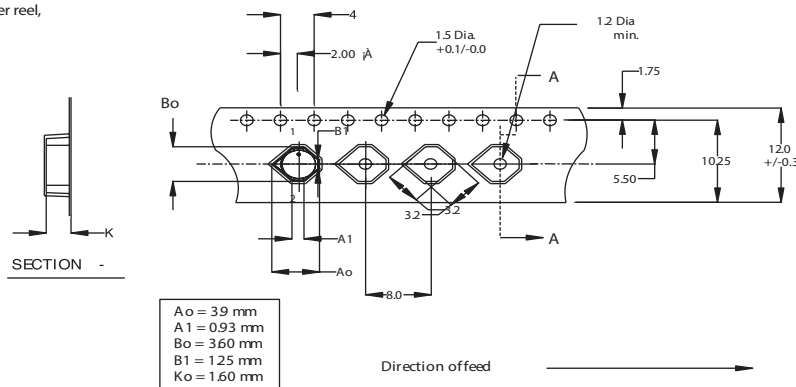

Temperature rise vs total loss loss

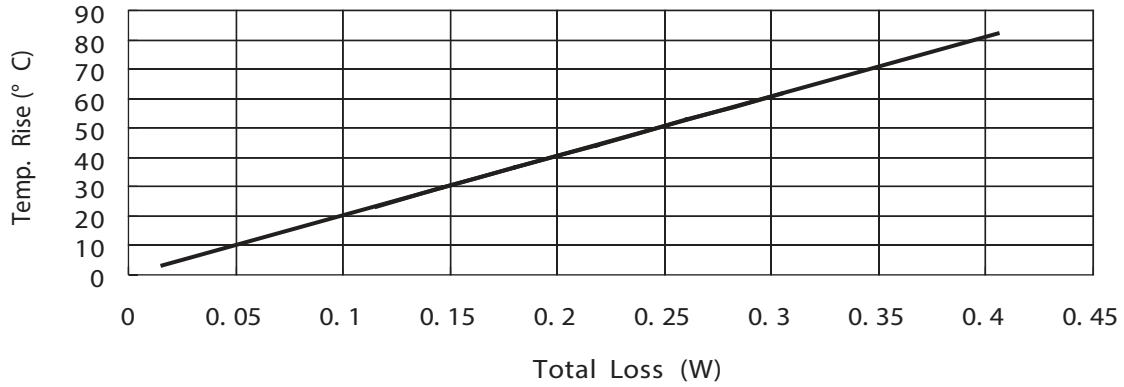

Core loss vs Bp-p

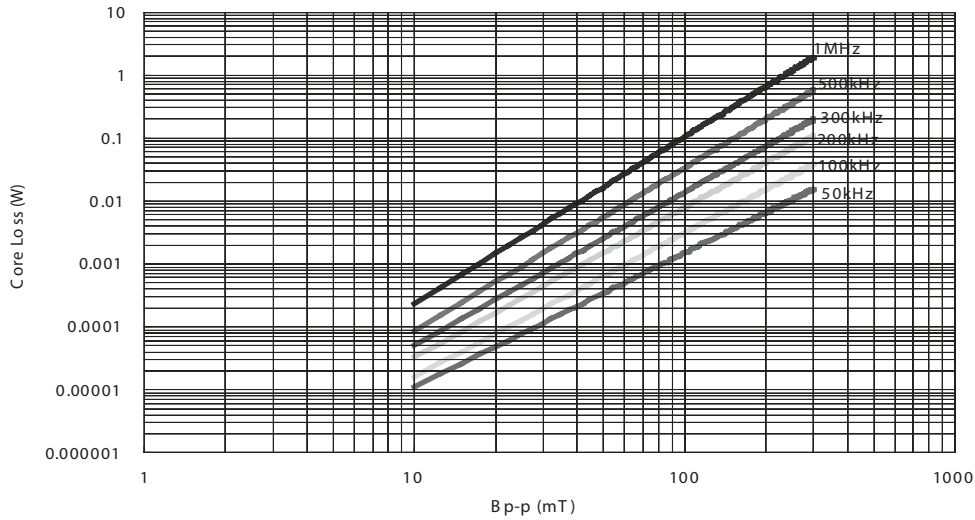

Inductance characteristics

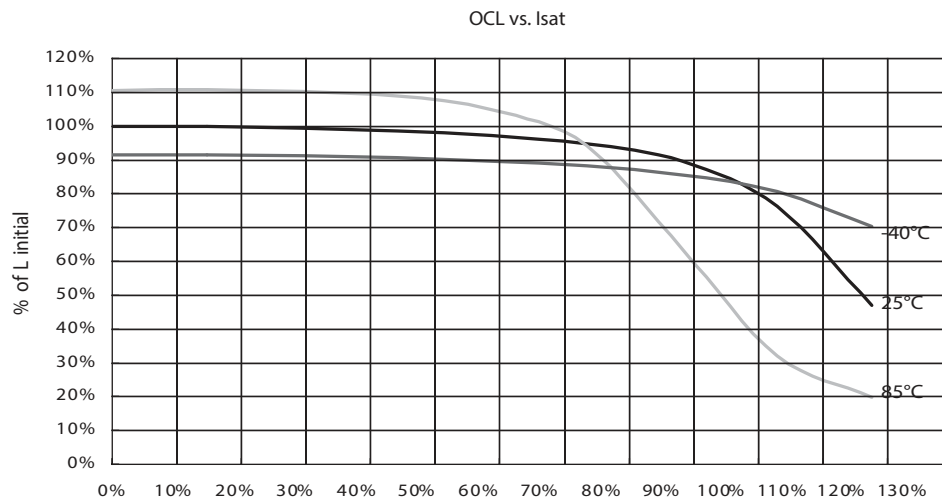

Solder Reflow Profile

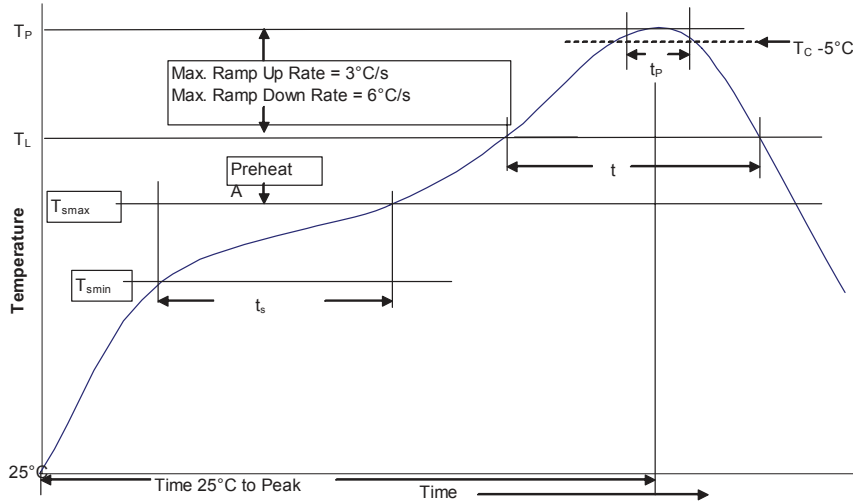

Table 1 - Standard SnPb Solder (T_c)

Package Thickness	Volume mm^3 <350	Volume mm^3 ≥ 350
<2.5mm	235°C	220°C
$\geq 2.5\text{mm}$	220°C	220°C

Table 2 - Lead (Pb) Free Solder (T_c)

Package Thickness	Volume mm^3 <350	Volume mm^3 350 - 2000	Volume mm^3 >2000
<1.6mm	260°C	260°C	260°C
1.6 – 2.5mm	260°C	250°C	245°C
>2.5mm	250°C	245°C	245°C

Reference JDEC J-STD-020

Profile Feature	Standard SnPb Solder	Lead (Pb) Free Solder
Preheat and Soak	• Temperature min. (T_{smin})	100°C
	• Temperature max. (T_{smax})	150°C
	• Time (T_{smin} to T_{smax}) (t_s)	60-120 Seconds
Average ramp up rate T_{smax} to T_p	3°C/ Second Max.	3°C/ Second Max.
Liquidous temperature (T_L)	183°C	217°C
Time at liquidous (t_L)	60-150 Seconds	60-150 Seconds
Peak package body temperature (T_p)*	Table 1	Table 2
Time (t_p)** within 5 °C of the specified classification temperature (T_c)	20 Seconds**	30 Seconds**
Average ramp-down rate (T_p to T_{smax})	6°C/ Second Max.	6°C/ Second Max.
Time 25°C to Peak Temperature	6 Minutes Max.	8 Minutes Max.

* Tolerance for peak profile temperature (T_p) is defined as a supplier minimum and a user maximum.

** Tolerance for time at peak profile temperature (t_p) is defined as a supplier minimum and a user maximum.

Life Support Policy: Eaton does not authorize the use of any of its products for use in life support devices or systems without the express written approval of an officer of the Company. Life support systems are devices which support or sustain life, and whose failure to perform, when properly used in accordance with instructions for use provided in the labeling, can be reasonably expected to result in significant injury to the user.

Eaton reserves the right, without notice, to change design or construction of any products and to discontinue or limit distribution of any products. Eaton also reserves the right to change or update, without notice, any technical information contained in this bulletin.

Eaton
Electronics Division
1000 Eaton Boulevard
Cleveland, OH 44122
United States
www.eaton.com/electronics

© 2017 Eaton
All Rights Reserved
Printed in USA
Publication No. 4128
August 2017