



GS1560A/GS1561 HD-LINX® II Dual-Rate Deserializer

Key Features

- SMPTE 292M and SMPTE 259M-C compliant descrambling and NRZI →NRZ decoding (with bypass)
- DVB-ASI 8b/10b decoding
- auto-configuration for HD-SDI and SD-SDI
- serial loop-through cable driver output selectable as reclocked or non-reclocked (GS1560A only)
- dual serial digital input buffers with 2 x 1 mux
- integrated serial digital signal termination
- integrated reclocker
- automatic or manual rate selection / indication (HD/SD)
- descrambler bypass option
- user selectable additional processing features including:
 - CRC, TRS, ANC data checksum, line number and EDH CRC error detection and correction
 - programmable ANC data detection
 - illegal code remapping
- internal flywheel for noise immune H, V, F extraction
- FIFO load Pulse
- 20-bit / 10-bit CMOS parallel output data bus
- 148.5MHz / 74.25MHz / 27MHz / 13.5MHz parallel digital output
- automatic standards detection and indication
- Pb-free and RoHS Compliant
- 1.8V core power supply and 3.3V charge pump power supply
- 3.3V digital I/O supply
- JTAG test interface
- small footprint compatible with GS9060, GS1532, and GS9062

Applications

- SMPTE 292M Serial Digital Interfaces
- SMPTE 259M-C Serial Digital Interfaces
- DVB-ASI Serial Digital Interfaces

Description

The GS1560A/GS1561 is a reclocking deserializer. When used in conjunction with the GS1524 Automatic Cable Equalizer and the GO1555/GO1525* Voltage Controlled Oscillator, a receive solution can be realized for HD-SD, SD-SDI and DVB-ASI applications.

In addition to reclocking and deserializing the input data stream, the GS1560A/GS1561 performs NRZI-to-NRZ decoding, descrambling as per SMPTE 259M-C/292M, and word alignment when operating in SMPTE mode. When operating in DVB-ASI mode, the device will word align the data to K28.5 sync characters and 8b/10b decode the received stream.

Two serial digital input buffers are provided with a 2x1 multiplexer to allow the device to select from one of two serial digital input signals.

The integrated reclocker features a very wide Input Jitter Tolerance of ± 0.3 UI (total 0.6 UI), a rapid asynchronous lock time, and full compliance with DVB-ASI data streams.

The GS1560A includes an integrated cable driver is for serial input loop-through applications. It can be selected to output either buffered or reclocked data. The cable driver also features an output mute on loss of signal, high impedance mode, adjustable signal swing, and automatic dual slew-rate selection depending on HD/SD operational requirements.

The GS1560A/GS1561 also includes a range of data processing functions such as error detection and correction, automatic standards detection, and EDH support. The device can also detect and extract SMPTE 352M payload identifier packets and independently identify the received video standard. This information is read from internal registers via the host interface port.

Line-based CRC errors, line number errors, TRS errors, EDH CRC errors and ancillary data checksum errors can all be detected.

Finally, the device can correct detected errors and insert new TRS ID words, line-based CRC words, ancillary data checksum words, EDH CRC words, and line numbers. Illegal code re-mapping is also available. All processing functions may be individually enabled or disabled via host interface control.

The GS1560A/GS1561 is Pb-free and the encapsulation compound does not contain halogenated flame retardant.

This component and all homogeneous subcomponents are RoHS compliant.

*For new designs use GO1555

Functional Block Diagrams

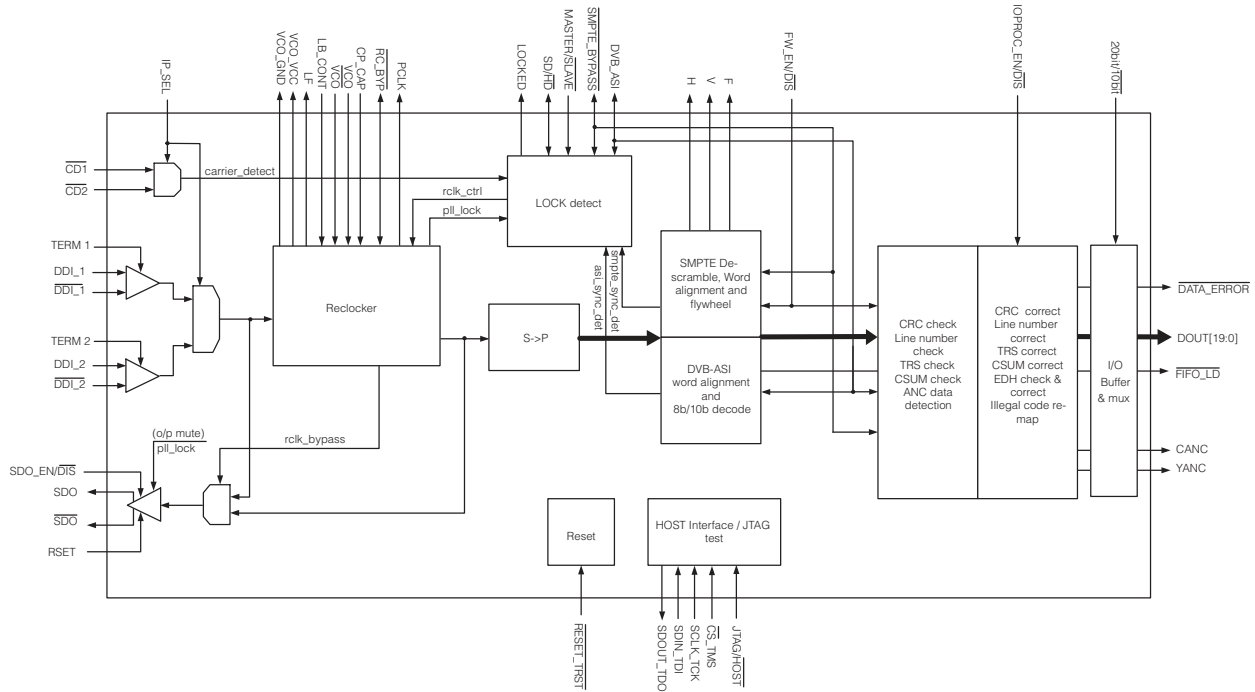

GS1560A Functional Block Diagram

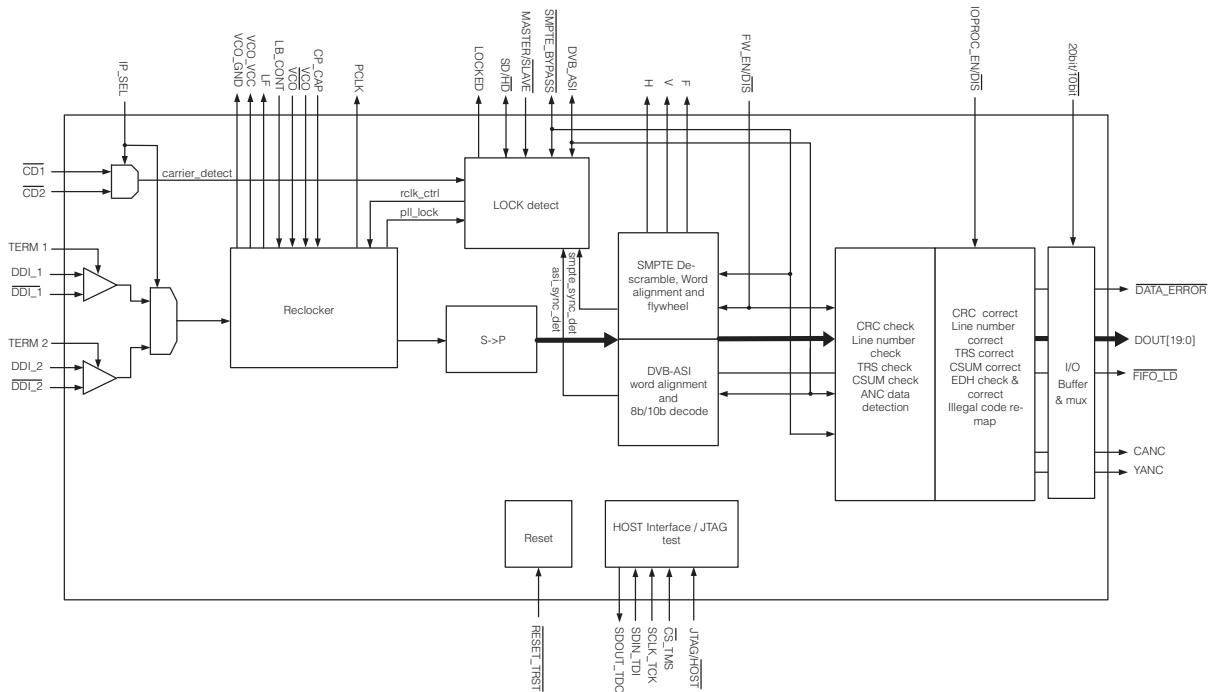

GS1561 Functional Block Diagram

Revision History

Version	ECR	PCN	Date	Changes and / or Modifications
6	134906	–	April 2005	Added Solder Reflow Profile description. Clarified setting of VD_STD[4:0], INT_PROG and STD_LOCK bits following a reset and/or removal of input. Minor correction to Typical Application Circuits for both parts. Added DVB-ASI Packet Counter information. Added Packaging Data section. Changed 'Green' references to RoHS Compliant.
7	136978	–	June 2005	Restored missing overlines to pin names. Corrected missing TERM pin in Serial Digital Input connection diagram. Rephrased RoHS compliance statement.
8	137405	–	September 2005	Conversion to Data Sheet. Added note on max device power and current to Table 2-1: DC Electrical Characteristics . Corrected Solder Reflow Profile labels.
9	140423	39452	May 2006	Corrected minor typing errors in Functional Block Diagram. Modified video format numbers for system 1125 on Table 3-4: Switch Line Position for Digital Systems .
10	143666	42774	January 2007	Recommended the new GO1555 VCO for new designs.
11	150195	50711	July 2008	DVB_ASI operation specification change in Master mode.

Contents

Key Features	1
Applications	1
Description	1
Functional Block Diagrams	2
1. Pin Out	6
1.1 Pin Assignment GS1560A	6
1.2 Pin Assignment GS1561	7
1.3 Pin Descriptions	8
2. Electrical Characteristics	19
2.1 Absolute Maximum Ratings	19
2.2 DC Electrical Characteristics	19
2.3 AC Electrical Characteristics	21
2.4 Solder Reflow Profiles	24
2.5 Input/Output Circuits	25
2.6 Host Interface Map	27
2.6.1 Host Interface Map (R/W Configurable Registers)	28
2.6.2 Host Interface Map (Read Only Registers)	29
3. Detailed Description	30

3.1 Functional Overview.....	30
3.2 Serial Digital Input	31
3.2.1 Input Signal Selection	31
3.2.2 Carrier Detect Input.....	31
3.2.3 Single Input Configuration.....	31
3.3 Serial Digital Reclocker	32
3.3.1 External VCO.....	32
3.3.2 Loop Bandwidth.....	32
3.4 Serial Digital Loop-Through Output (GS1560A only).....	32
3.4.1 Output Swing	33
3.4.2 Reclocker Bypass Control.....	34
3.4.3 Serial Digital Output Mute.....	34
3.5 Serial-To-Parallel Conversion	35
3.6 Modes Of Operation	35
3.6.1 Lock Detect.....	35
3.6.2 Master Mode.....	36
3.6.3 Slave Mode.....	37
3.7 SMPTE Functionality	38
3.7.1 SMPTE Descrambling and Word Alignment	38
3.7.2 Internal Flywheel	38
3.7.3 Switch Line Lock Handling.....	39
3.7.4 HVF Timing Signal Generation	43
3.8 DVB-ASI Functionality	45
3.8.1 Transport Packet Format.....	45
3.8.2 DVB-ASI 8b/10b Decoding and Word Alignment.....	45
3.8.3 Status Signal Outputs	46
3.9 Data Through Mode.....	46
3.10 Additional Processing Functions	46
3.10.1 FIFO Load Pulse	47
3.10.2 Ancillary Data Detection and Indication	48
3.10.3 SMPTE 352M Payload Identifier	52
3.10.4 Automatic Video Standard and Data Format Detection.....	52
3.10.5 Error Detection and Indication.....	56
3.10.6 Error Correction and Insertion	61
3.10.7 EDH Flag Detection	63
3.11 Parallel Data Outputs.....	65
3.11.1 Parallel Data Bus Buffers	65
3.11.2 Parallel Output in SMPTE Mode.....	66
3.11.3 Parallel Output in DVB-ASI Mode.....	66
3.11.4 Parallel Output in Data-Through Mode.....	66
3.11.5 Parallel Output Clock (PCLK)	67
3.12 GSPI Host Interface.....	68
3.12.1 Command Word Description.....	68
3.12.2 Data Read and Write Timing	69
3.12.3 Configuration and Status Registers.....	69

3.13 JTAG.....	70
3.14 Device Power Up.....	72
3.15 Device Reset.....	72
4. Application Reference Design	73
4.1 GS1560A Typical Application Circuit (Part A).....	73
4.2 GS1560A Typical Application Circuit (Part B)	74
4.3 GS1561 Typical Application Circuit (Part A).....	75
4.4 GS1561 Typical Application Circuit (Part B).....	76
5. References & Relevant Standards	77
6. Package & Ordering Information	78
6.1 Package Dimensions.....	78
6.2 Packaging Data.....	79
6.3 Ordering Information.....	79

1. Pin Out

1.1 Pin Assignment GS1560A

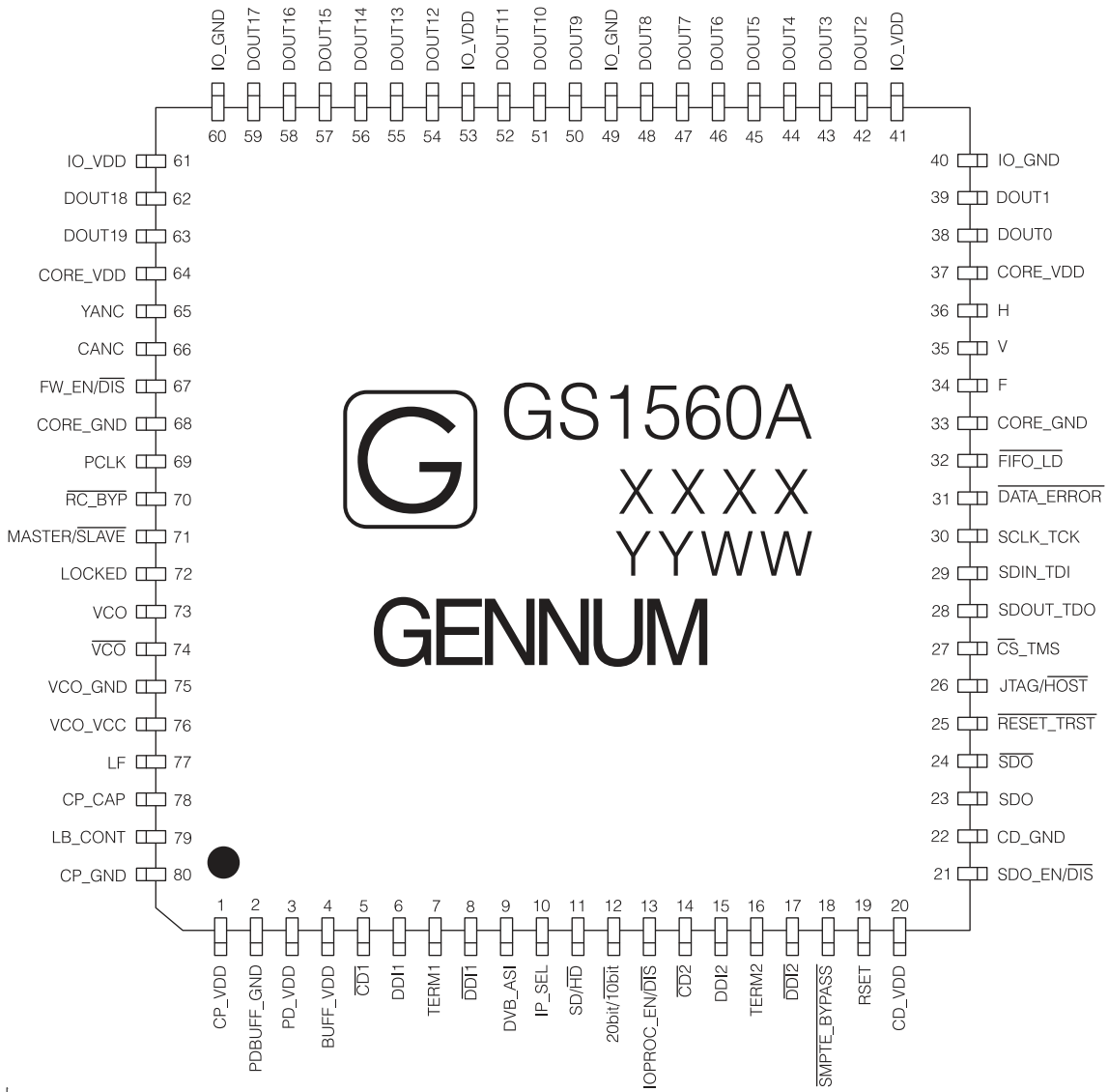

1.2 Pin Assignment GS1561

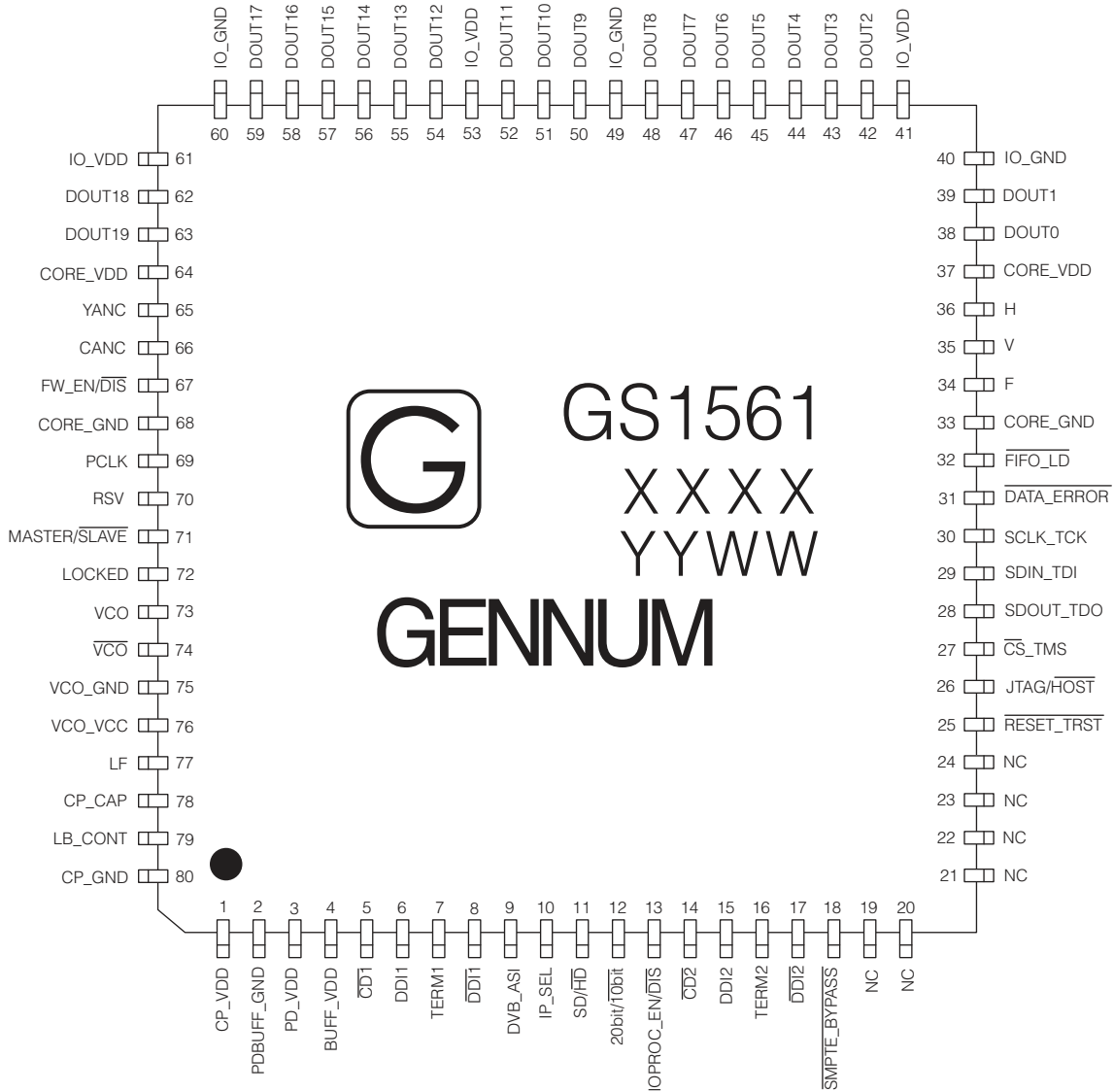

1.3 Pin Descriptions

Table 1-1: Pin Descriptions

Pin Number	Name	Timing	Type	Description
1	CP_VDD	–	Power	Power supply connection for the charge pump. Connect to +3.3V DC analog.
2	PDBUFF_GND	–	Power	Ground connection for the phase detector and serial digital input buffers. Connect to analog GND.
3	PD_VDD	–	Power	Power supply connection for the phase detector. Connect to +1.8V DC analog.
4	BUFF_VDD	–	Power	Power supply connection for the serial digital input buffers. Connect to +1.8V DC analog.
5	$\overline{\text{CD1}}$	Non Synchronous	Input	<p>STATUS SIGNAL INPUT Signal levels are LVCMOS/LVTTL compatible.</p> <p>Used to indicate the presence of a serial digital input signal. Normally generated by a Gennum automatic cable equalizer.</p> <p>When LOW, the serial digital input signal received at the DDI1 and $\overline{\text{DDI1}}$ pins is considered valid.</p> <p>When HIGH, the associated serial digital input signal is considered to be invalid. In this case, the LOCKED signal is set LOW and all parallel outputs are muted.</p>
6, 8	DDI1, $\overline{\text{DDI1}}$	Analog	Input	Differential input pair for serial digital input 1.
7	TERM1	Analog	Input	Termination for serial digital input 1. AC couple to EQ_GND.
9	DVB_ASI	Non Synchronous	Input / Output	<p>CONTROL SIGNAL INPUT / STATUS SIGNAL OUTPUT Signal levels are LVCMOS/LVTTL compatible.</p> <p>This pin will be an input set by the application layer in slave mode.</p> <p>This pin and its function are not supported in Master mode.</p> <p>Slave Mode (MASTER/$\overline{\text{SLAVE}}$ = LOW) When set HIGH in conjunction with $\text{SD}/\overline{\text{HD}}$ = HIGH and $\overline{\text{SMPTE_BYPASS}}$ = LOW, the device will be configured to operate in DVB-ASI mode.</p> <p>When set LOW, the device will not support the decoding or word alignment of received DVB-ASI data.</p>
10	IP_SEL	Non Synchronous	Input	<p>CONTROL SIGNAL INPUT Signal levels are LVCMOS/LVTTL compatible.</p> <p>Used to select DDI1 / $\overline{\text{DDI1}}$ or DDI2 / $\overline{\text{DDI2}}$ as the serial digital input signal, and $\overline{\text{CD1}}$ or $\overline{\text{CD2}}$ as the carrier detect input signal.</p> <p>When set HIGH, DDI1 / $\overline{\text{DDI1}}$ is selected as the serial digital input and $\overline{\text{CD1}}$ is selected as the carrier detect input signal.</p> <p>When set LOW, DDI2 / $\overline{\text{DDI2}}$ serial digital input and $\overline{\text{CD2}}$ carrier detect input signal is selected.</p>

Table 1-1: Pin Descriptions (Continued)

Pin Number	Name	Timing	Type	Description
11	SD/ $\overline{\text{HD}}$	Non Synchronous	Input / Output	<p>CONTROL SIGNAL INPUT / STATUS SIGNAL OUTPUT Signal levels are LVCMOS/LVTTL compatible.</p> <p>This pin will be an input set by the application layer in slave mode, and will be an output set by the device in master mode.</p> <p>Master Mode (MASTER/$\overline{\text{SLAVE}}$ = HIGH) The SD/$\overline{\text{HD}}$ signal will be LOW whenever the received serial digital signal is 1.485Gb/s or 1.485/1.001Gb/s. The SD/$\overline{\text{HD}}$ signal will be HIGH whenever the received serial digital signal is 270Mb/s.</p> <p>Slave Mode (MASTER/$\overline{\text{SLAVE}}$ = LOW) When set LOW, the device will be configured for the reception of 1.485Gb/s or 1.485/1.001Gb/s signals only and will not lock to any other serial digital signal. When set HIGH, the device will be configured for the reception of 270Mb/s signals only and will not lock to any other serial digital signal.</p> <p>NOTE: When in slave mode, reset the device after the SD/$\overline{\text{HD}}$ input has been initially configured, and after each subsequent SD/$\overline{\text{HD}}$ data rate change.</p> <p>NOTE: This pin has an internal pull-up resistor of 100K.</p>
12	20bit/ $\overline{10\text{bit}}$	Non Synchronous	Input	<p>CONTROL SIGNAL INPUT Signal levels are LVCMOS/LVTTL compatible.</p> <p>Used to select the output data bus width in SMPTE or Data-Through modes. This signal is ignored in DVB-ASI mode.</p> <p>When set HIGH, the parallel output will be 20-bit demultiplexed data. When set LOW, the parallel outputs will be 10-bit multiplexed data.</p>
13	IOPROC_EN/ $\overline{\text{DIS}}$	Non Synchronous	Input	<p>CONTROL SIGNAL INPUT Signal levels are LVCMOS/LVTTL compatible.</p> <p>Used to enable or disable I/O processing features.</p> <p>When set HIGH, the following I/O processing features of the device are enabled:</p> <ul style="list-style-type: none"> • EDH CRC Error Correction (SD-only) • ANC Data Checksum Correction • Line-based CRC Error Correction (HD-only) • Line Number Error Correction (HD-only) • TRS Error Correction • Illegal Code Remapping <p>To enable a subset of these features, keep IOPROC_EN/$\overline{\text{DIS}}$ HIGH and disable the individual feature(s) in the IOPROC_DISABLE register accessible via the host interface.</p> <p>When set LOW, the I/O processing features of the device are disabled, regardless of whether the features are enabled in the IOPROC_DISABLE register.</p>

Table 1-1: Pin Descriptions (Continued)

Pin Number	Name	Timing	Type	Description
14	$\overline{CD2}$	Non Synchronous	Input	<p>STATUS SIGNAL INPUT Signal levels are LVCMOS/LVTTL compatible.</p> <p>Used to indicate the presence of a serial digital input signal. Normally generated by a Gennum automatic cable equalizer.</p> <p>When LOW, the serial digital input signal received at the DDI2 and $\overline{DDI2}$ pins is considered valid.</p> <p>When HIGH, the associated serial digital input signal is considered to be invalid. In this case, the LOCKED signal is set LOW and all parallel outputs are muted.</p>
15, 17	DDI2, $\overline{DDI2}$	Analog	Input	Differential input pair for serial digital input 2.
16	TERM2	Analog	Input	Termination for serial digital input 2. AC couple to PDBUFF_GND.
18	$\overline{SMPTE_BYPASS}$	Non Synchronous	Input / Output	<p>CONTROL SIGNAL INPUT / STATUS SIGNAL OUTPUT Signal levels are LVCMOS/LVTTL compatible.</p> <p>This pin will be an input set by the application layer in slave mode, and will be an output set by the device in master mode.</p> <p>Master Mode (MASTER/\overline{SLAVE} = HIGH) The $\overline{SMPTE_BYPASS}$ signal will be HIGH only when the device has locked to a SMPTE compliant data stream. It will be LOW otherwise.</p> <p>Slave Mode (MASTER/\overline{SLAVE} = LOW) When set HIGH in conjunction with DVB_ASI = LOW, the device will be configured to operate in SMPTE mode. All I/O processing features may be enabled in this mode.</p> <p>When set LOW, the device will not support the descrambling, decoding or word alignment of received SMPTE data. No I/O processing features will be available.</p>
19	RSET	Analog	Input	<p>GS1560A Used to set the serial digital loop-through output signal amplitude. Connect to CD_VDD through 281Ω +/- 1% for 800mV_{p-p} single-ended output swing.</p>
	NC	–	–	<p>GS1561 No Connect.</p>
20	CD_VDD	–	Power	<p>GS1560A Power supply connection for the serial digital cable driver. Connect to +1.8V DC analog.</p>
	NC	–	–	<p>GS1561 No Connect.</p>

Table 1-1: Pin Descriptions (Continued)

Pin Number	Name	Timing	Type	Description
21	SDO_EN/ $\overline{\text{DIS}}$	Non Synchronous	Input	<p>GS1560A CONTROL SIGNAL INPUT Signal levels are LVCMOS/LVTTL compatible. Used to enable or disable the serial digital output loop-through stage. When set LOW, the serial digital output signals SDO and $\overline{\text{SDO}}$ are disabled and become high impedance. When set HIGH, the serial digital output signals SDO and $\overline{\text{SDO}}$ are enabled.</p>
	NC	–	–	<p>GS1561 No Connect.</p>
22	CD_GND	–	Power	<p>GS1560A Ground connection for the serial digital cable driver. Connect to analog GND.</p>
	NC	–	–	<p>GS1561 No Connect.</p>
23, 24	SDO, $\overline{\text{SDO}}$	Analog	Output	<p>GS1560A Serial digital loop-through output signal operating at 1.485Gb/s, 1.485/1.001Gb/s, or 270Mb/s. The slew rate of these outputs is automatically controlled to meet SMPTE 292M and 259M specifications according to the setting of the SD/$\overline{\text{HD}}$ pin.</p>
	NC	–	–	<p>GS1561 No Connect.</p>
25	$\overline{\text{RESET_TRST}}$	Non Synchronous	Input	<p>CONTROL SIGNAL INPUT Signal levels are LVCMOS/LVTTL compatible. Used to reset the internal operating conditions to default settings and to reset the JTAG test sequence. Host Mode (JTAG/$\overline{\text{HOST}}$ = LOW) When asserted LOW, all functional blocks will be set to default conditions and all input and output signals become high impedance, including the serial digital outputs SDO and $\overline{\text{SDO}}$. Must be set HIGH for normal device operation. NOTE: When in slave mode, reset the device after the SD/$\overline{\text{HD}}$ input has been initially configured, and after each subsequent SD/HD data rate change. JTAG Test Mode (JTAG/$\overline{\text{HOST}}$ = HIGH) When asserted LOW, all functional blocks will be set to default and the JTAG test sequence will be held in reset. When set HIGH, normal operation of the JTAG test sequence resumes.</p>

Table 1-1: Pin Descriptions (Continued)

Pin Number	Name	Timing	Type	Description
26	JTAG/HOST	Non Synchronous	Input	<p>CONTROL SIGNAL INPUT Signal levels are LVCMOS/LVTTL compatible.</p> <p>Used to select JTAG Test Mode or Host Interface Mode.</p> <p>When set HIGH, $\overline{CS_TMS}$, SDOUT_TDO, SDI_TDI and SCLK_TCK are configured for JTAG boundary scan testing.</p> <p>When set LOW, $\overline{CS_TMS}$, SDOUT_TDO, SDI_TDI and SCLK_TCK are configured as GSPI pins for normal host interface operation.</p>
27	$\overline{CS_TMS}$	Synchronous with SCLK_TCK	Input	<p>CONTROL SIGNAL INPUT Signal levels are LVCMOS/LVTTL compatible.</p> <p>Chip Select / Test Mode Select</p> <p>Host Mode (JTAG/HOST = LOW) $\overline{CS_TMS}$ operates as the host interface chip select, \overline{CS}, and is active LOW.</p> <p>JTAG Test Mode (JTAG/HOST = HIGH) $\overline{CS_TMS}$ operates as the JTAG test mode select, TMS, and is active HIGH.</p> <p>NOTE: If the host interface is not being used, tie this pin HIGH.</p>
28	SDOUT_TDO	Synchronous with SCLK_TCK	Output	<p>CONTROL SIGNAL OUTPUT Signal levels are LVCMOS/LVTTL compatible.</p> <p>Serial Data Output / Test Data Output</p> <p>Host Mode (JTAG/HOST = LOW) SDOUT_TDO operates as the host interface serial output, SDOUT, used to read status and configuration information from the internal registers of the device.</p> <p>JTAG Test Mode (JTAG/HOST = HIGH) SDOUT_TDO operates as the JTAG test data output, TDO.</p>
29	SDIN_TDI	Synchronous with SCLK_TCK	Input	<p>CONTROL SIGNAL INPUT Signal levels are LVCMOS/LVTTL compatible.</p> <p>Serial Data In / Test Data Input</p> <p>Host Mode (JTAG/HOST = LOW) SDIN_TDI operates as the host interface serial input, SDIN, used to write address and configuration information to the internal registers of the device.</p> <p>JTAG Test Mode (JTAG/HOST = HIGH) SDIN_TDI operates as the JTAG test data input, TDI.</p> <p>NOTE: If the host interface is not being used, tie this pin HIGH.</p>
30	SCLK_TCK	Non Synchronous	Input	<p>CONTROL SIGNAL INPUT Signal levels are LVCMOS/LVTTL compatible.</p> <p>Serial Data Clock / Test Clock.</p> <p>Host Mode (JTAG/HOST = LOW) SCLK_TCK operates as the host interface burst clock, SCLK. Command and data read/write words are clocked into the device synchronously with this clock.</p> <p>JTAG Test Mode (JTAG/HOST = HIGH) SCLK_TCK operates as the JTAG test clock, TCK.</p> <p>NOTE: If the host interface is not being used, tie this pin HIGH.</p>

Table 1-1: Pin Descriptions (Continued)

Pin Number	Name	Timing	Type	Description
31	$\overline{\text{DATA_ERROR}}$	Synchronous with PCLK	Output	<p>STATUS SIGNAL OUTPUT Signal levels are LVCMOS/LVTTL compatible.</p> <p>The $\overline{\text{DATA_ERROR}}$ signal will be LOW when an error within the received data stream has been detected by the device. This pin is a logical 'OR'ing of all detectable errors listed in the internal ERROR_STATUS register.</p> <p>Once an error is detected, $\overline{\text{DATA_ERROR}}$ will remain LOW until the start of the next video frame / field, or until the ERROR_STATUS register is read via the host interface.</p> <p>The $\overline{\text{DATA_ERROR}}$ signal will be HIGH when the received data stream has been detected without error.</p> <p>NOTE: It is possible to program which error conditions are monitored by the device by setting appropriate bits of the ERROR_MASK register HIGH. All error conditions are detected by default.</p>
32	$\overline{\text{FIFO_LD}}$	Synchronous with PCLK	Output	<p>CONTROL SIGNAL OUTPUT Signal levels are LVCMOS/LVTTL compatible.</p> <p>Used as a control signal for external FIFO(s).</p> <p>Normally HIGH but will go LOW for one PCLK period at SAV.</p>
33, 68	CORE_GND	–	Power	Ground connection for the digital core logic. Connect to digital GND.
34	F	Synchronous with PCLK	Output	<p>STATUS SIGNAL OUTPUT Signal levels are LVCMOS/LVTTL compatible.</p> <p>Used to indicate the ODD / EVEN field of the video signal.</p> <p>The F signal will be HIGH for the entire period of field 2 as indicated by the F bit in the received TRS signals.</p> <p>The F signal will be LOW for all lines in field 1 and for all lines in progressive scan systems.</p>
35	V	Synchronous with PCLK	Output	<p>STATUS SIGNAL OUTPUT Signal levels are LVCMOS/LVTTL compatible.</p> <p>Used to indicate the portion of the video field / frame that is used for vertical blanking.</p> <p>The V signal will be HIGH for the entire vertical blanking period as indicated by the V bit in the received TRS signals.</p> <p>The V signal will be LOW for all lines outside of the vertical blanking interval.</p>
36	H	Synchronous with PCLK	Output	<p>STATUS SIGNAL OUTPUT Signal levels are LVCMOS/LVTTL compatible.</p> <p>Used to indicate the portion of the video line containing active video data. H signal timing is configurable via the H_CONFIG bit of the IOPROC_DISABLE register accessible via the host interface.</p> <p>Active Line Blanking (H_CONFIG = 0_h) The H signal will be HIGH for the entire horizontal blanking period, including the EAV and SAV TRS words, and LOW otherwise. This is the default setting.</p> <p>TRS Based Blanking (H_CONFIG = 1_h) The H signal will be HIGH for the entire horizontal blanking period as indicated by the H bit in the received TRS ID words, and LOW otherwise.</p>

Table 1-1: Pin Descriptions (Continued)

Pin Number	Name	Timing	Type	Description
37, 64	CORE_VDD	–	Power	Power supply connection for the digital core logic. Connect to +1.8V DC digital.
38, 39, 42-48, 50	DOUT[0:9]	Synchronous with PCLK	Output	<p>PARALLEL DATA BUS Signal levels are LVCMOS/LVTTL compatible. DOUT9 is the MSB and DOUT0 is the LSB.</p> <hr/> <p>HD 20-bit mode SD/HD = LOW 20bit/10bit = HIGH</p> <p>Chroma data output in SMPTE mode SMPTE_BYPASS = HIGH DVB_ASI = LOW</p> <p>Data output in Data-Through mode SMPTE_BYPASS = LOW DVB_ASI = LOW</p> <hr/> <p>HD 10-bit mode SD/HD = LOW 20bit/10bit = LOW</p> <p>Forced LOW in all modes.</p> <hr/> <p>SD 20-bit mode SD/HD = HIGH 20bit/10bit = HIGH</p> <p>Chroma data output in SMPTE mode SMPTE_BYPASS = HIGH DVB_ASI = LOW</p> <p>Data output in Data-Through mode SMPTE_BYPASS = LOW DVB_ASI = LOW</p> <p>Forced LOW in DVB-ASI mode SMPTE_BYPASS = LOW DVB_ASI = HIGH</p> <hr/> <p>SD 10-bit mode SD/HD = HIGH 20bit/10bit = LOW</p> <p>Forced LOW in all modes.</p>
40, 49, 60	IO_GND	–	Power	Ground connection for digital I/O buffers. Connect to digital GND.
41, 53, 61	IO_VDD	–	Power	Power supply connection for digital I/O buffers. Connect to +3.3V DC digital.

Table 1-1: Pin Descriptions (Continued)

Pin Number	Name	Timing	Type	Description				
51, 52, 54-59, 62, 63	DOUT[19:10]	Synchronous with PCLK	Output	<p>PARALLEL DATA BUS Signal levels are LVCMOS/LVTTL compatible. DOUT19 is the MSB and DOUT10 is the LSB.</p> <hr/> <p>HD 20-bit mode SD/\overline{HD} = LOW 20bit/$\overline{10bit}$ = HIGH</p> <p>Luma data output in SMPTE mode SMPTE_BYPASS = HIGH DVB_ASI = LOW</p> <p>Data output in Data-Through mode SMPTE_BYPASS = LOW DVB_ASI = LOW</p> <hr/> <p>HD 10-bit mode SD/\overline{HD} = LOW 20bit/$\overline{10bit}$ = LOW</p> <p>Multiplexed Luma and Chroma data output in SMPTE mode SMPTE_BYPASS = HIGH DVB_ASI = LOW</p> <p>Data output in Data-Through mode SMPTE_BYPASS = LOW DVB_ASI = LOW</p> <hr/> <p>SD 20-bit mode SD/\overline{HD} = HIGH 20bit/$\overline{10bit}$ = HIGH</p> <p>Luma data output in SMPTE mode SMPTE_BYPASS = HIGH DVB_ASI = LOW</p> <p>Data output in Data-Through mode SMPTE_BYPASS = LOW DVB_ASI = LOW</p> <p>DVB-ASI data in DVB-ASI mode SMPTE_BYPASS = LOW DVB_ASI = HIGH</p> <hr/> <p>SD 10-bit mode SD/\overline{HD} = HIGH 20bit/$\overline{10bit}$ = LOW</p> <p>Multiplexed Luma and Chroma data output in SMPTE mode SMPTE_BYPASS = HIGH DVB_ASI = LOW</p> <p>Data input in data through mode SMPTE_BYPASS = LOW DVB_ASI = LOW</p> <p>DVB-ASI data in DVB-ASI mode SMPTE_BYPASS = LOW DVB_ASI = HIGH</p>				
				65	YANC	Synchronous with PCLK	Output	<p>STATUS SIGNAL OUTPUT Signal levels are LVCMOS/LVTTL compatible. Used to indicate the presence of ancillary data in the video stream.</p> <p>HD Mode (SD/\overline{HD} = LOW) The YANC signal will be HIGH when the device has detected VANC or HANC data in the luma video stream and LOW otherwise.</p> <p>SD Mode (SD/\overline{HD} = LOW) For 20-bit demultiplexed data (20bit/$\overline{10bit}$ = HIGH), the YANC signal will be HIGH when VANC or HANC data is detected in the luma video stream and LOW otherwise.</p> <p>For 10-bit multiplexed data (20bit/$\overline{10bit}$ = LOW), the YANC signal will be HIGH when VANC or HANC data is detected anywhere in the data stream and LOW otherwise.</p>

Table 1-1: Pin Descriptions (Continued)

Pin Number	Name	Timing	Type	Description								
66	CANC	Synchronous with PCLK	Output	<p>STATUS SIGNAL OUTPUT Signal levels are LVCMOS/LVTTL compatible.</p> <p>Used to indicate the presence of ancillary data in the video stream.</p> <p>HD Mode ($SD/\overline{HD} = \text{LOW}$) The CANC signal will be HIGH when the device has detected VANC or HANC data in the chroma video stream and LOW otherwise.</p> <p>SD Mode ($SD/\overline{HD} = \text{LOW}$) For 20-bit demultiplexed data ($20\text{bit}/\overline{10\text{bit}} = \text{HIGH}$), the CANC signal will be HIGH when VANC or HANC data is detected in the chroma video stream and LOW otherwise.</p> <p>For 10-bit multiplexed data ($20\text{bit}/\overline{10\text{bit}} = \text{LOW}$), the CANC signal will be HIGH when VANC or HANC data is detected anywhere in the data stream and LOW otherwise.</p>								
67	FW_EN/ \overline{DIS}	Non Synchronous	Input	<p>CONTROL SIGNAL INPUT Signal levels are LVCMOS/LVTTL compatible.</p> <p>Used to enable or disable the noise immune flywheel of the device.</p> <p>When set HIGH, the internal flywheel is enabled. This flywheel is used in the extraction and generation of TRS timing signals, in automatic video standards detection, and in manual switch line lock handling.</p> <p>When set LOW, the internal flywheel is disabled and TRS correction and insertion is unavailable.</p>								
69	PCLK	–	Output	<p>PARALLEL DATA BUS CLOCK Signal levels are LVCMOS/LVTTL compatible.</p> <table border="1"> <tbody> <tr> <td>HD 20-bit mode</td> <td>PCLK = 74.25MHz or 74.25/1.001MHz</td> </tr> <tr> <td>HD 10-bit mode</td> <td>PCLK = 148.5MHz or 148.5/1.001MHz</td> </tr> <tr> <td>SD 20-bit mode</td> <td>PCLK = 13.5MHz</td> </tr> <tr> <td>SD 10-bit mode</td> <td>PCLK = 27MHz</td> </tr> </tbody> </table>	HD 20-bit mode	PCLK = 74.25MHz or 74.25/1.001MHz	HD 10-bit mode	PCLK = 148.5MHz or 148.5/1.001MHz	SD 20-bit mode	PCLK = 13.5MHz	SD 10-bit mode	PCLK = 27MHz
HD 20-bit mode	PCLK = 74.25MHz or 74.25/1.001MHz											
HD 10-bit mode	PCLK = 148.5MHz or 148.5/1.001MHz											
SD 20-bit mode	PCLK = 13.5MHz											
SD 10-bit mode	PCLK = 27MHz											

Table 1-1: Pin Descriptions (Continued)

Pin Number	Name	Timing	Type	Description
70	$\overline{RC_BYP}$	Non Synchronous	Input /Output	<p>GS1560A CONTROL SIGNAL INPUT / STATUS SIGNAL OUTPUT Signal levels are LVCMOS/LVTTL compatible.</p> <p>This pin will be an input set by the application layer in slave mode, and will be an output set by the device in master mode.</p> <p>Master Mode (MASTER/\overline{SLAVE} = HIGH) The $\overline{RC_BYP}$ signal will be HIGH only when the device has successfully locked to a SMPTE compliant input data stream. In this case, the serial digital loop-through output will be a relocked version of the input. The $\overline{RC_BYP}$ signal will be LOW whenever the input does not conform to a SMPTE compliant data stream. In this case, the serial digital loop-through output will be a buffered version of the input.</p> <p>Slave Mode (MASTER/\overline{SLAVE} = LOW) When set HIGH, the serial digital output will be a relocked version of the input signal regardless of whether the device is in SMPTE, DVB-ASI or Data-Through mode. When set LOW, the serial digital output will be a buffered version of the input signal in all modes.</p>
	RSV	–	–	<p>GS1561 Connect to CORE_VDD through 2.2kΩ</p>
71	MASTER/ \overline{SLAVE}	Non Synchronous	Input	<p>CONTROL SIGNAL INPUT Signal levels are LVCMOS/LVTTL compatible.</p> <p>Used to determine the input / output selection for the DVB_ASI, SD/HD, RC_BYP and SMPTE_BYPASS pins.</p> <p>When set HIGH, the GS1560A is set to operate in master mode where SD/HD, RC_BYP (GS1560A only) and SMPTE_BYPASS become status signal output pins set by the device. In this mode, the GS1560A will automatically detect, relock, deserialize and process SD SMPTE and HD SMPTE input data.</p> <p>When set LOW, the GS1560A is set to operate in slave mode where DVB_ASI, SD/HD, RC_BYP (GS1560A only) and SMPTE_BYPASS become control signal input pins. In this mode, the application layer must set these external device pins for the correct reception of either SMPTE or DVB-ASI data. Slave mode also supports the relocking and deserializing of data not conforming to SMPTE or DVB-ASI streams.</p>
72	LOCKED	Synchronous with PCLK	Output	<p>STATUS SIGNAL OUTPUT Signal levels are LVCMOS / LVTTL compatible.</p> <p>The LOCKED signal will be HIGH whenever the device has correctly received and locked to SMPTE compliant data in SMPTE mode or DVB-ASI compliant data in DVB-ASI mode. It will be LOW otherwise.</p>
73, 74	VCO, \overline{VCO}	Analog	Input	<p>Differential inputs for the external VCO reference signal. For single ended devices such as the GO1555/GO1525*, \overline{VCO} should be AC coupled to VCO_GND. VCO is nominally 1.485GHz. *For new designs use GO1555</p>

Table 1-1: Pin Descriptions (Continued)

Pin Number	Name	Timing	Type	Description
75	VCO_GND	–	Output Power	Ground reference for the external voltage controlled oscillator. Connect to pins 2, 4, 6, and 8 of the GO1555/GO1525*. This pin is an output. Should be isolated from all other grounds. *For new designs use GO1555
76	VCO_VCC	–	Output Power	Power supply for the external voltage controlled oscillator. Connect to pin 7 of the GO1555/GO1525*. This pin is an output. Should be isolated from all other power supplies. *For new designs use GO1555
77	LF	Analog	Output	Control voltage to external voltage controlled oscillator. Nominally +1.25V DC.
78	CP_CAP	Analog	Input	PLL lock time constant capacitor connection. Normally connected to VCO_GND through 2.2nF.
79	LB_CONT	Analog	Input	Control voltage to set the loop bandwidth of the integrated reclocker. Normally connected to VCO_GND through 40k Ω
80	CP_GND	–	Power	Ground connection for the charge pump. Connect to analog GND.

2. Electrical Characteristics

2.1 Absolute Maximum Ratings

Parameter	Value/Units
Supply Voltage Core	-0.3V to +2.1V
Supply Voltage I/O	-0.3V to +4.6V
Input Voltage Range (any input)	-2.0V to + 5.25V
Ambient Operating Temperature	-20°C ≤ T _A ≤ 85°C
Storage Temperature	-40°C ≤ T _{STG} ≤ 125°C
Lead Temperature (soldering, 10 sec)	230°C
ESD Protection On All Pins (see Note 2)	1kV

NOTES:

1. See reflow solder profile ([Solder Reflow Profiles on page 24](#))
2. HBM, per JESDA-114B

2.2 DC Electrical Characteristics

Table 2-1: DC Electrical Characteristics

T_A = 0°C to 70°C, unless otherwise specified.

Parameter	Symbol	Conditions	Min	Typ	Max	Units	Test Levels	Notes
System								
Operation Temperature Range	T _A	–	0	–	70	°C	–	1
Digital Core Supply Voltage	CORE_VDD	–	1.65	1.8	1.95	V	1	1
Digital I/O Supply Voltage	IO_VDD	–	3.0	3.3	3.6	V	1	1
Charge Pump Supply Voltage	CP_VDD	–	3.0	3.3	3.6	V	1	1
Phase Detector Supply Voltage	PD_VDD	–	1.65	1.8	1.95	V	1	1
Input Buffer Supply Voltage	BUFF_VDD	–	1.65	1.8	1.95	V	1	1
Cable Driver Supply Voltage	CD_VDD	–	1.71	1.8	1.89	V	1	1
External VCO Supply Voltage Output	VCO_VCC	–	2.25	2.50	2.75	V	1	–

Table 2-1: DC Electrical Characteristics (Continued)T_A = 0°C to 70°C, unless otherwise specified.

Parameter	Symbol	Conditions	Min	Typ	Max	Units	Test Levels	Notes
+1.8V Supply Current GS1560A	I _{1V8}	–	–	–	245	mA	1	4
+1.8V Supply Current GS1561	I _{1V8}	–	–	–	200	mA	1	–
+3.3V Supply Current	I _{3V3}	–	–	–	55	mA	1	5
Total Device Power GS1560A	P _D	–	–	–	625	mW	5	4, 5
Total Device Power GS1561	P _D	–	–	–	545	mW	5	5
Digital I/O								
Input Logic LOW	V _{IL}	–	–	–	0.8	V	1	–
Input Logic HIGH	V _{IH}	–	2.1	–	–	V	1	–
Output Logic LOW	V _{OL}	8mA	–	0.2	0.4	V	1	–
Output Logic HIGH	V _{OH}	8mA	IO_VDD - 0.4	–	–	V	1	–
Input								
Input Bias Voltage	V _B	–	–	1.45	–	V	6	2
RSET Voltage (GS1560A only)	V _{RSET}	RSET=281Ω	0.54	0.6	0.66	V	1	3
Output (GS1560A only)								
Output Common Mode Voltage	V _{CMOUT}	75Ω load, RSET=281Ω, SD and HD	0.8	1.0	1.2	V	1	–

TEST LEVELS

1. Production test at room temperature and nominal supply voltage with guardbands for supply and temperature ranges.
2. Production test at room temperature and nominal supply voltage with guardbands for supply and temperature ranges using correlated test.
3. Production test at room temperature and nominal supply voltage.
4. QA sample test.
5. Calculated result based on Level 1, 2, or 3.
6. Not tested. Guaranteed by design simulations.
7. Not tested. Based on characterization of nominal parts.
8. Not tested. Based on existing design/characterization data of similar product.
9. Indirect test.

NOTES

1. All DC and AC electrical parameters within specification.
2. Input common mode is set by internal biasing resistors.
3. Set by the value of the RSET resistor. (GS1560A only)
4. Loop-through enabled. (GS1560A only)
5. Measured in 20-bit mode.

2.3 AC Electrical Characteristics

Table 2-2: AC Electrical Characteristics

T_A = 0°C to 70°C, unless otherwise shown

Parameter	Symbol	Conditions	Min	Typ	Max	Units	Test Levels	Notes
System								
Serial Digital Input Jitter Tolerance	IJT	Nominal loop bandwidth	0.6	–	–	UI	1	1
Master Mode Asynchronous Lock Time		No data to HD	–	–	468	us	6,7	2
		HD to SD	–	–	260	us	6,7	2
		No data to SD	–	–	340	us	6,7	2
		SD to HD	–	–	256	us	6,7	2
Slave Mode Asynchronous Lock Time		No data to HD	–	–	240	us	6,7	2
		No data to SD	–	–	197	us	6,7	2
		No data to DVB-ASI	–	–	68	us	6,7	2
Device Latency		10-bit SD	–	21	–	PCLK	6	–
		20-bit HD	–	21	–	PCLK	6	–
		DVB-ASI	–	11	–	PCLK	6	–
Reset Pulse Width	t _{reset}	–	1	–	–	ms	7	6
Serial Digital Differential Input								
Serial Input Data Rate	DR _{DDI}	–	–	1.485, 1.485/1.001, 270	–	Gb/s Gb/s Mb/s	1	–
Serial Digital Input Signal Swing	ΔV _{DDI}	Differential with internal 100Ω input termination	200	600	1000	mV _{p-p}	1	–
Serial Digital Output (GS1560A only)								
Serial Output Data Rate	DR _{SDO}	–	–	1.485, 1.485/1.001, 270	–	Gb/s Gb/s Mb/s	1	–
Serial Output Swing	ΔV _{SDO}	RSET = 281Ω Load = 75Ω V _{DD} = 1.8V	720	800	880	mV _{p-p}	1	–
Serial Output Rise Time 20% ~ 80%	tr _{SDO}	ORL compensation using recommended circuit — HD signal	–	200	260	ps	1	–
		ORL compensation using recommended circuit — SD signal	400	550	1500	ps	1	–

Table 2-2: AC Electrical Characteristics (Continued)T_A = 0°C to 70°C, unless otherwise shown

Parameter	Symbol	Conditions	Min	Typ	Max	Units	Test Levels	Notes
Serial Output Fall Time 20% ~ 80%	t _{fSDO}	ORL compensation using recommended circuit — HD signal	–	235	260	ps	1	–
		ORL compensation using recommended circuit — SD signal	400	550	1500	ps	1	–
Serial Output Intrinsic Jitter	t _{IJ}	Pseudorandom and pathological HD signal	–	90	125	ps	1	3
		Pseudorandom and pathological SD signal	–	270	350	ps	1	3
Serial Output Duty Cycle Distortion	DCD _{SDO}	HD (1.485Gb/s)	–	10	–	ps	6,7	4
		SD (270Mb/s)	–	20	–	ps	6,7	4
Parallel Output								
Parallel Clock Frequency	f _{PCLK}	–	13.5	–	148.5	MHz	1	–
Parallel Clock Duty Cycle	DC _{PCLK}	–	40	50	60	%	1	–
Output Data Hold Time	t _{OH}	20-bit HD	1.0	–	–	ns	1	5
		10-bit SD, 50% PCLK Duty Cycle	19.5	–	–	ns	1	5
Output Data Delay Time	t _{OD}	20-bit HD	–	–	4.5	ns	1	5
		10-bit SD, 50% PCLK Duty Cycle	–	–	22.8	ns	1	5
Output Data Rise/Fall Time	t _{r/tf}	–	–	–	1.5	ns	6,7	5

Table 2-2: AC Electrical Characteristics (Continued)

T_A = 0°C to 70°C, unless otherwise shown

Parameter	Symbol	Conditions	Min	Typ	Max	Units	Test Levels	Notes
GSPI								
GSPI Input Clock Frequency	f _{SCLK}	–	–	–	6.6	MHz	1	–
GSPI Input Clock Duty Cycle	DC _{SCLK}	–	40	50	60	%	6,7	–
GSPI Input Data Setup Time	–	–	0	–	–	ns	6,7	–
GSPI Input Data Hold Time	–	–	–	–	1.43	ns	6,7	–
GSPI Output Data Hold Time	–	–	2.10	–	–	ns	6,7	–
GSPI Output Data Delay Time	–	–	–	–	7.27	ns	6,7	–

TEST LEVELS

1. Production test at room temperature and nominal supply voltage with guardbands for supply and temperature ranges.
2. Production test at room temperature and nominal supply voltage with guardbands for supply and temperature ranges using correlated test.
3. Production test at room temperature and nominal supply voltage.
4. QA sample test.
5. Calculated result based on Level 1, 2, or 3.
6. Not tested. Guaranteed by design simulations.
7. Not tested. Based on characterization of nominal parts.
8. Not tested. Based on existing design/characterization data of similar product.
9. Indirect test.

NOTES

1. 6MHz sinewave modulation.
2. HD = 1080i, SD = 525i
3. Serial Digital Output Reclocked ($\overline{RC_BYP}$ = HIGH).
4. Serial Duty Cycle Distortion is defined here to be the difference between the width of a '1' bit, and the width of a '0' bit. (GS1560A only)
5. With 15pF load. (GS1560A only)
6. See [Device Reset on page 72, Figure 3-16](#). (GS1560A only)

2.4 Solder Reflow Profiles

The device is manufactured with Matte-Sn terminations and is compatible with both standard eutectic and Pb-free solder reflow profiles. The recommended standard eutectic reflow profile is shown in Figure 2-1. MSL qualification was performed using the maximum Pb-free reflow profile shown in Figure 2-2.

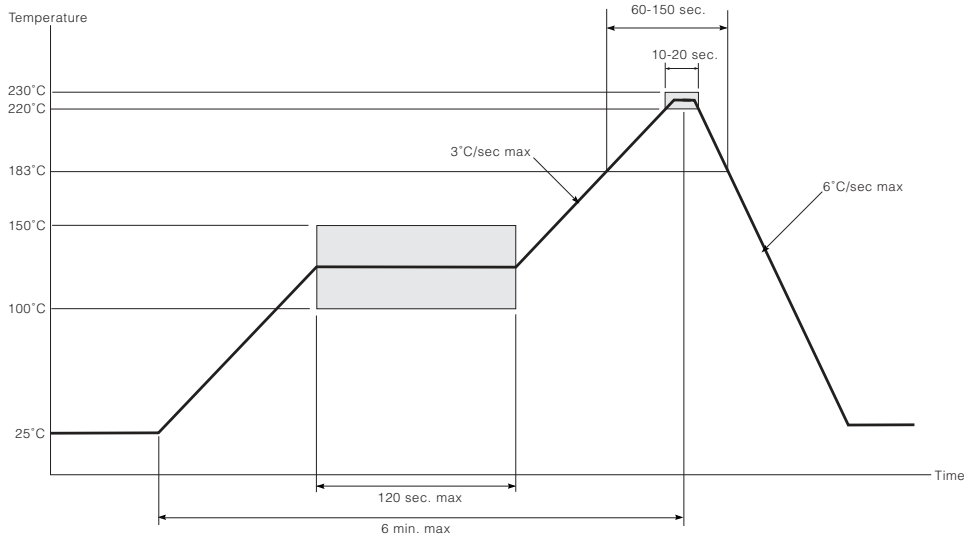

Figure 2-1: Standard Eutectic Solder Reflow Profile

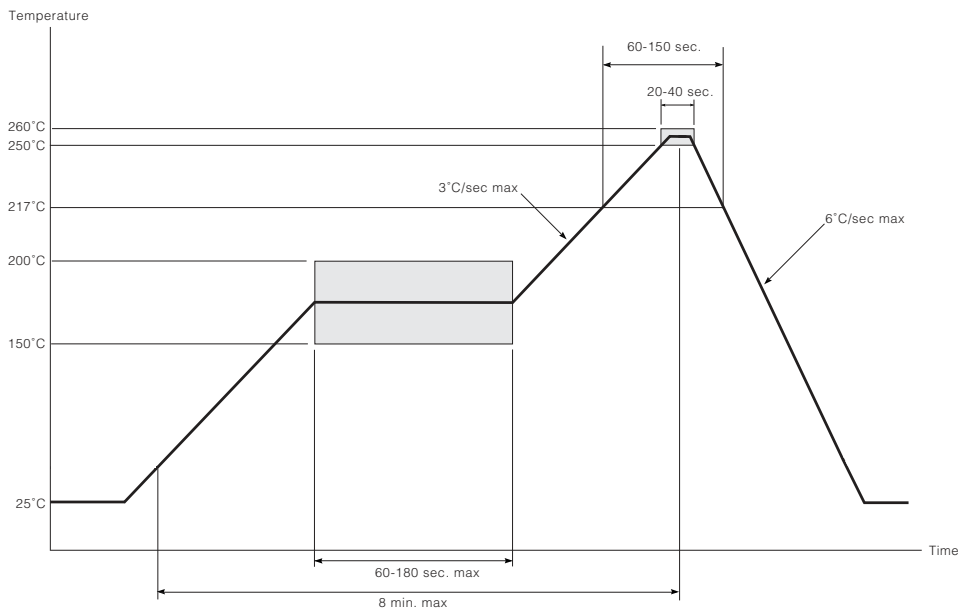

Figure 2-2: Maximum Pb-free Solder Reflow Profile (Pb-free package)

2.5 Input/Output Circuits

All resistors in ohms, all capacitors in farads, unless otherwise shown.

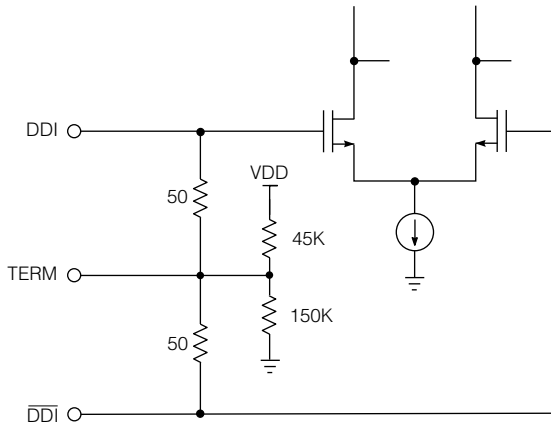

Figure 2-3: Serial Digital Input

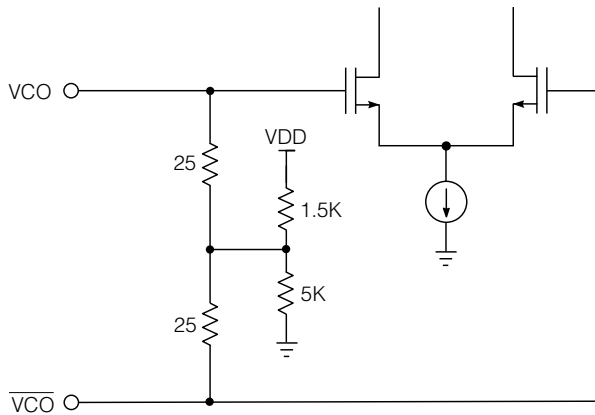

Figure 2-4: VCO Input

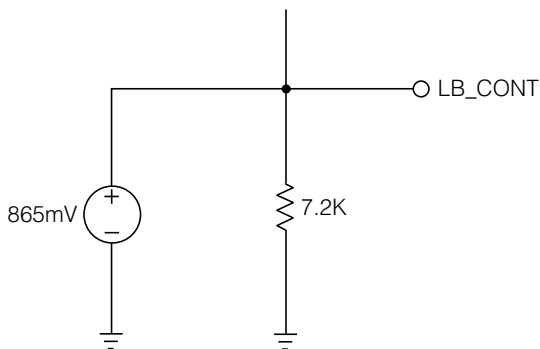

Figure 2-5: PLL Loop Bandwidth Control

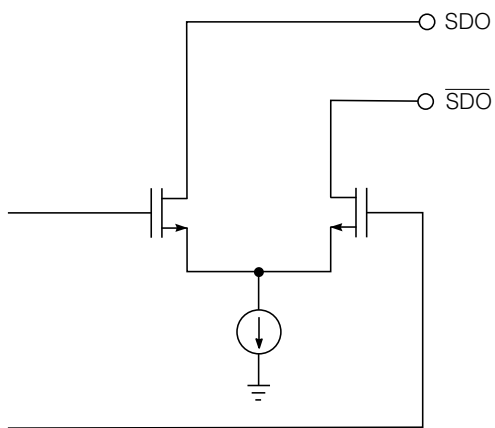

Figure 2-6: Serial Digital Output (GS1560A only)

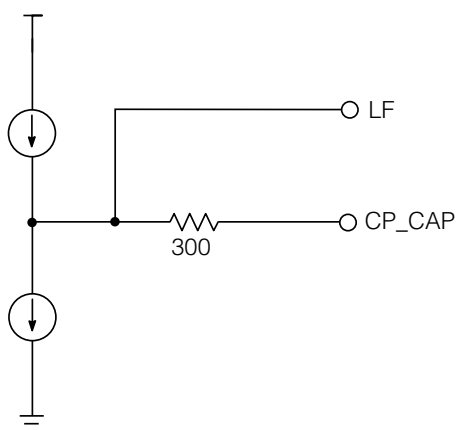

Figure 2-7: VCO Control Output & PLL Lock Time Capacitor

2.6 Host Interface Map

REGISTER NAME	ADDRESS	15	14	13	12	11	10	9	8	7	6	5	4	3	2	1	0
ERROR_MASK	01Ah	Not Used	Not Used	Not Used	Not Used	Not Used	Not Used	FE_CRC_ERR_MASK	AP_CRC_ERR_MASK	LOCK_ERR_MASK	CCS_ERR_MASK	YCS_ERR_MASK	CCRC_ERR_MASK	YCRC_ERR_MASK	LNUM_ERR_MASK	SAVE_ERR_MASK	EAV_ERR_MASK
FF_LINE_END_F1	019h	Not Used	Not Used	Not Used	Not Used	Not Used	Not Used	b9	b8	b7	b6	b5	b4	b3	b2	b1	b0
FF_LINE_START_F1	018h	Not Used	Not Used	Not Used	Not Used	Not Used	Not Used	b9	b8	b7	b6	b5	b4	b3	b2	b1	b0
FF_LINE_END_F0	017h	Not Used	Not Used	Not Used	Not Used	Not Used	Not Used	b9	b8	b7	b6	b5	b4	b3	b2	b1	b0
FF_LINE_START_F0	016h	Not Used	Not Used	Not Used	Not Used	Not Used	Not Used	b9	b8	b7	b6	b5	b4	b3	b2	b1	b0
AP_LINE_END_F1	015h	Not Used	Not Used	Not Used	Not Used	Not Used	Not Used	b9	b8	b7	b6	b5	b4	b3	b2	b1	b0
AP_LINE_START_F1	014h	Not Used	Not Used	Not Used	Not Used	Not Used	Not Used	b9	b8	b7	b6	b5	b4	b3	b2	b1	b0
AP_LINE_END_F0	013h	Not Used	Not Used	Not Used	Not Used	Not Used	Not Used	b9	b8	b7	b6	b5	b4	b3	b2	b1	b0
AP_LINE_START_F0	012h	Not Used	Not Used	Not Used	Not Used	Not Used	Not Used	b9	b8	b7	b6	b5	b4	b3	b2	b1	b0
RASTER_STRUCTURE4	011h	Not Used	Not Used	Not Used	Not Used	Not Used	Not Used	b9	b8	b7	b6	b5	b4	b3	b2	b1	b0
RASTER_STRUCTURE3	010h	Not Used	Not Used	Not Used	Not Used	Not Used	Not Used	b9	b8	b7	b6	b5	b4	b3	b2	b1	b0
RASTER_STRUCTURE2	00Fh	Not Used	Not Used	Not Used	Not Used	b11	b10	b9	b8	b7	b6	b5	b4	b3	b2	b1	b0
RASTER_STRUCTURE1	00Eh	Not Used	Not Used	Not Used	Not Used	b11	b10	b9	b8	b7	b6	b5	b4	b3	b2	b1	b0
VIDEO_FORMAT_OUT_B	00Dh	VFO4-b7	VFO4-b6	VFO4-b5	VFO4-b4	VFO4-b3	VFO4-b2	VFO4-b1	VFO4-b0	VFO3-b7	VFO3-b6	VFO3-b5	VFO3-b4	VFO3-b3	VFO3-b2	VFO3-b1	VFO3-b0
VIDEO_FORMAT_OUT_A	00Ch	VFO2-b7	VFO2-b6	VFO2-b5	VFO2-b4	VFO2-b3	VFO2-b2	VFO2-b1	VFO2-b0	VFO1-b7	VFO1-b6	VFO1-b5	VFO1-b4	VFO1-b3	VFO1-b2	VFO1-b1	VFO1-b0
	00Bh																
	00Ah																
ANC_TYPE5	009h	b15	b14	b13	b12	b11	b10	b9	b8	b7	b6	b5	b4	b3	b2	b1	b0
ANC_TYPE4	008h	b15	b14	b13	b12	b11	b10	b9	b8	b7	b6	b5	b4	b3	b2	b1	b0
ANC_TYPE3	007h	b15	b14	b13	b12	b11	b10	b9	b8	b7	b6	b5	b4	b3	b2	b1	b0
ANC_TYPE2	006h	b15	b14	b13	b12	b11	b10	b9	b8	b7	b6	b5	b4	b3	b2	b1	b0
ANC_TYPE1	005h	b15	b14	b13	b12	b11	b10	b9	b8	b7	b6	b5	b4	b3	b2	b1	b0
VIDEO_STANDARD	004h	Not Used	VDS-b4	VDS-b3	VDS-b2	VDS-b1	VDS-b0	INT_PROG	STD_LOCK	CDF-b3	CDF-b2	CDF-b1	CDF-b0	YDF-b3	YDF-b2	YDF-b1	YDF-b0
EDH_FLAG	003h	Not Used	ANC-UES	ANC-IDA	ANC-IDH	ANC-EDA	ANC-EDH	FF-UES	FF-IDA	FF-IDH	FF-EDA	FF-EDH	AP-UES	AP-IDA	AP-IDH	AP-EDA	AP-EDH
	002h																
ERROR_STATUS	001h	Not Used	Not Used	Not Used	Not Used	Not Used	VD_STD_ERR	FE_CRC_ERR	AP_CRC_ERR	LOCK_ERR	CCS_ERR	YCS_ERR	CCRC_ERR	YCRC_ERR	LNUM_ERR	SAVE_ERR	EAV_ERR
IOPROC_DISABLE	000h	Not Used	Not Used	Not Used	Not Used	Not Used	Not Used	Not Used	H_CONFIG	Not Used	Not Used	ILLEGAL_REMAP	EDH_CRC_INS	ANC_CSUM_NS	CRC_INS	LNUM_INS	TRIS_INS

2.6.1 Host Interface Map (R/W Configurable Registers)

REGISTER NAME	ADDRESS	15	14	13	12	11	10	9	8	7	6	5	4	3	2	1	0
ERROR_MASK	01Ah																
FF_LINE_END_F1	019h							b9	b8	b7	b6	b5	b4	b3	b2	b1	b0
FF_LINE_START_F1	018h							b9	b8	b7	b6	b5	b4	b3	b2	b1	b0
FF_LINE_END_F0	017h							b9	b8	b7	b6	b5	b4	b3	b2	b1	b0
FF_LINE_START_F0	016h							b9	b8	b7	b6	b5	b4	b3	b2	b1	b0
AP_LINE_END_F1	015h							b9	b8	b7	b6	b5	b4	b3	b2	b1	b0
AP_LINE_START_F1	014h							b9	b8	b7	b6	b5	b4	b3	b2	b1	b0
AP_LINE_END_F0	013h							b9	b8	b7	b6	b5	b4	b3	b2	b1	b0
AP_LINE_START_F0	012h							b9	b8	b7	b6	b5	b4	b3	b2	b1	b0
	011h																
	010h																
	00Fh																
	00Eh																
	00Dh																
	00Ch																
	00Bh																
	00Ah																
ANC_TYPE5	009h	b15	b14	b13	b12	b11	b10	b9	b8	b7	b6	b5	b4	b3	b2	b1	b0
ANC_TYPE4	008h	b15	b14	b13	b12	b11	b10	b9	b8	b7	b6	b5	b4	b3	b2	b1	b0
ANC_TYPE3	007h	b15	b14	b13	b12	b11	b10	b9	b8	b7	b6	b5	b4	b3	b2	b1	b0
ANC_TYPE2	006h	b15	b14	b13	b12	b11	b10	b9	b8	b7	b6	b5	b4	b3	b2	b1	b0
ANC_TYPE1	005h	b15	b14	b13	b12	b11	b10	b9	b8	b7	b6	b5	b4	b3	b2	b1	b0
	004h																
	003h																
	002h																
	001h																
IOPROC_DISABLE	000h								H_CONFIG			ILLEGAL_REMAP	EDH_CRC_NS	ANC_CSUM_J_NS	CRC_INS	LNUM_INS	TR5_INS

2.6.2 Host Interface Map (Read Only Registers)

REGISTER NAME	ADDRESS	15	14	13	12	11	10	9	8	7	6	5	4	3	2	1	0
	01Ah																
	019h																
	018h																
	017h																
	016h																
	015h																
	014h																
	013h																
	012h																
	011h						b10	b9	b8	b7	b6	b5	b4	b3	b2	b1	b0
RASTER_STRUCTURE4	010h						b10	b9	b8	b7	b6	b5	b4	b3	b2	b1	b0
RASTER_STRUCTURE3	00fh																
RASTER_STRUCTURE2	00eh					b11	b10	b9	b8	b7	b6	b5	b4	b3	b2	b1	b0
RASTER_STRUCTURE1	00dh					b11	b10	b9	b8	b7	b6	b5	b4	b3	b2	b1	b0
VIDEO_FORMAT_OUT_B	00ch	VFO4-b7	VFO4-b6	VFO4-b5	VFO4-b4	VFO4-b3	VFO4-b2	VFO4-b1	VFO4-b0	VFO3-b7	VFO3-b6	VFO3-b5	VFO3-b4	VFO3-b3	VFO3-b2	VFO3-b1	VFO3-b0
VIDEO_FORMAT_OUT_A	00bh	VFO2-b7	VFO2-b6	VFO2-b5	VFO2-b4	VFO2-b3	VFO2-b2	VFO2-b1	VFO2-b0	VFO1-b7	VFO1-b6	VFO1-b5	VFO1-b4	VFO1-b3	VFO1-b2	VFO1-b1	VFO1-b0
	00ah																
	009h																
	008h																
	007h																
	006h																
	005h																
VIDEO_STANDARD	004h		VDS-b4	VDS-b3	VDS-b2	VDS-b1	VDS-b0	INT_PROG	STD_LOCK	CD-F-b3	CD-F-b2	CD-F-b1	CD-F-b0	YDF-b3	YDF-b2	YDF-b1	YDF-b0
EDH_FLAG	003h		ANC-UES	ANC-IDA	ANC-IDH	ANC-EDA	ANC-EDH	FF-UES	FF-IDA	FF-IDH	FF-EDA	FF-EDH	AP-UES	AP-IDA	AP-IDH	AP-EDA	AP-EDH
ERROR_STATUS	002h						VD_STD_ERR	FF_CRC_ERR	AP_CRC_ERR	LOCK_ERR	CCS_ERR	YCS_ERR	CGRC_ERR	YCRC_ERR	LNUM_ERR	SAV_ERR	EAV_ERR
	001h																
	000h																

3. Detailed Description

3.1 Functional Overview

The GS1560A/GS1561 is a dual-rate reclocking deserializer. An integrated serial digital loop-through output is also included on the GS1560A only. When used in conjunction with the multi-rate GS1524 Adaptive Cable Equalizer and the external GO1555/GO1525* Voltage Controlled Oscillator, a receive solution at 1.485Gb/s, 1.485/1.001Gb/s or 270Mb/s is realized.

The device has two basic modes of operation which determine precisely how SMPTE or DVB-ASI compliant input data streams are reclocked and processed.

In master mode, ($\overline{\text{MASTER/SLAVE}} = \text{HIGH}$), the GS1560A/GS1561 will automatically detect, reclock, deserialize and process SD SMPTE 259M-C or HD SMPTE 292M input data.

In slave mode, ($\overline{\text{MASTER/SLAVE}} = \text{LOW}$), the application layer must set external device pins for the correct reception of either SMPTE or DVB-ASI data. Slave mode also supports the reclocking and deserializing of data not conforming to SMPTE or DVB-ASI streams.

The GS1560A includes an integrated cable driver is for serial input loop-through applications. It can be selected to output either buffered or reclocked data. The cable driver also features an output mute on loss of signal, high impedance mode, adjustable signal swing, and automatic dual slew-rate selection depending on HD/SD operational requirements.

In the digital signal processing core, several data processing functions are implemented including error detection and correction and automatic video standards detection. These features are all enabled by default, but may be individually disabled via internal registers accessible through the GSPI host interface.

Finally, the GS1560A/GS1561 contains a JTAG interface for boundary scan test implementations.

*For new designs use GO1555

3.2 Serial Digital Input

The GS1560A/GS1561 contains two current mode differential serial digital input buffers, allowing the device to be connected to two SMPTE 259M-C or 292M compliant input signals.

Both input buffers have internal 50Ω termination resistors which are connected to ground via the TERM1 and TERM2 pins. The input common mode level is set by internal biasing resistors such that the serial digital input signals must be AC coupled into the device. Gennum recommends using a capacitor value of $4.7\mu\text{F}$ to accommodate pathological signals.

The input buffers use a separate power supply of +1.8V DC supplied via the BUFF_VDD and PDBUFF_GND pins.

3.2.1 Input Signal Selection

A 2x1 input multiplexer is provided to allow the application layer to select between the two serial digital input streams using a single external pin. When IP_SEL is set HIGH, serial digital input 1 (DDI1 / $\overline{\text{DDI1}}$) is selected as the input to the GS1560A/GS1561's reclocker stage. When IP_SEL is set LOW, serial digital input 2 (DDI2 / $\overline{\text{DDI2}}$) is selected.

3.2.2 Carrier Detect Input

For each of the differential inputs, an associated carrier detect input signal is included, ($\overline{\text{CD1}}$ and $\overline{\text{CD2}}$). These signals are generated by Gennum's family of automatic cable equalizers.

When LOW, $\overline{\text{CDx}}$ indicates that a valid serial digital data stream is being delivered to the GS1560A/GS1561 by the equalizer. When HIGH, the serial digital input to the device should be considered invalid. If no equalizer precedes the device, the application layer should set $\overline{\text{CD1}}$ and $\overline{\text{CD2}}$ accordingly.

NOTE: If the GS1524 Automatic Cable Equalizer is used, the MUTE/ $\overline{\text{CD}}$ output signal from that device must be translated to TTL levels before passing to the GS1560A/GS1561 $\overline{\text{CDx}}$ inputs. See [GS1560A Typical Application Circuit \(Part A\) on page 73](#) for a recommended transistor network that will set the correct voltage levels.

A 2x1 input multiplexer is also provided for these signals. The internal carrier_detect signal is determined by the setting of the IP_SEL pin and is used by the lock detect block of the GS1560A/GS1561 to determine the lock status of the device, (see [Lock Detect on page 35](#)).

3.2.3 Single Input Configuration

If the application requires a single differential input, the second set of inputs may be left unconnected. Tie the associated carrier detect pin HIGH, and leave the termination pin unconnected.

3.3 Serial Digital Reclocker

The output of the 2x1 serial digital input multiplexer passes to the GS1560A/GS1561's internal reclocker stage. The function of this block is to lock to the input data stream, extract a clean clock, and retime the serial digital data to remove high frequency jitter.

The reclocker was designed with a 'hexabang' phase and frequency detector. That is, the PFD used can identify six 'degrees' of phase / frequency misalignment between the input data stream and the clock signal provided by the VCO, and correspondingly signal the charge pump to produce six different control voltages. This results in fast and accurate locking of the PLL to the data stream.

In master mode, the operating center frequency of the reclocker is toggled between 270Mb/s and 1.485Gb/s by the lock detect block, (see [Lock Detect on page 35](#)). In slave mode, however, the center frequency is determined entirely by the $\overline{\text{SD/HD}}$ input control signal set by the application layer.

If lock is achieved, the reclocker provides an internal pll_lock signal to the lock detect block of the device.

3.3.1 External VCO

The GS1560A/GS1561 requires the external GO1555/GO1525* Voltage Controlled Oscillator as part of the reclocker's phase-locked loop. This external VCO implementation was chosen to ensure high quality reclocking.

Power for the external VCO is generated entirely by the GS1560A/GS1561 from an integrated voltage regulator. The internal regulator uses +3.3V DC supplied via the CP_VDD / CP_GND pins to provide +2.5V DC on the VCO_VCC / VCO_GND pins.

The control voltage to the VCO is output from the GS1560A/GS1561 on the LF pin and requires 4.7k Ω pull-up and pull-down resistors to ensure correct operation.

The GO1555/GO1525* produces a 1.485GHz reference signal for the reclocker, input on the VCO pin of the GS1560A/GS1561. Both LF and VCO signals should be referenced to the supplied VCO_GND as shown in the recommended application circuit of [GS1560A Typical Application Circuit \(Part A\) on page 73](#).

*For new designs use GO1555

3.3.2 Loop Bandwidth

The loop bandwidth of the integrated reclocker is nominally 1.4MHz, but may be increased or decreased via the LB_CONT pin. It is recommended that this pin be connected to VCO_GND through 39.2k Ω to maximize the input jitter tolerance of the device.

3.4 Serial Digital Loop-Through Output (GS1560A only)

The GS1560A contains an integrated current mode differential serial digital cable driver with automatic slew rate control. When enabled, this serial digital output provides an active loop-through of the input signal.

To enable the loop-through output, $\overline{\text{SDO_EN/DIS}}$ must be set HIGH by the application layer. Setting the $\overline{\text{SDO_EN/DIS}}$ signal LOW will cause the SDO and $\overline{\text{SDO}}$ output pins to become high impedance, resulting in reduced device power consumption.

With suitable external return loss matching circuitry, the GS1560A's loop-through outputs will provide a minimum output return loss of -15dB at SD rates. Gennum recommends using the GS1528 SDI Dual Slew-Rate Cable Driver to meet output return loss specifications at HD rates.

The integrated cable driver uses a separate power supply of +1.8V DC supplied via the CD_VDD and CD_GND pins.

3.4.1 Output Swing

Nominally, the voltage swing of the serial digital loop-through output is $800\text{mV}_{\text{p-p}}$ single-ended into a 75Ω load. This is set externally by connecting the RSET pin to CD_VDD through 281Ω .

The loop-through output swing may be decreased by increasing the value of the RSET resistor. The relationship is approximated by the curve shown in Figure 3-1.

Alternatively, the serial digital output can drive $800\text{mV}_{\text{p-p}}$ into a 50Ω load. Since the output swing is reduced by a factor of approximately one third when the smaller load is used, the RSET resistor must be 187Ω to obtain $800\text{mV}_{\text{p-p}}$.

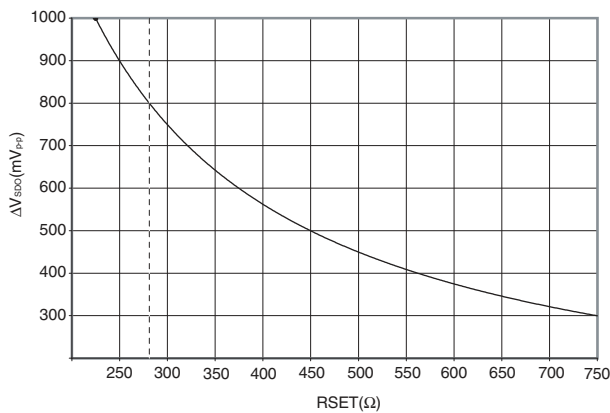

Figure 3-1: Serial Digital Loop-Through Output Swing

3.4.2 Reclocker Bypass Control

The serial digital loop-through output may be either a buffered version of the serial digital input signal, or a reclocked version of that signal.

When operating in slave mode, the application layer may choose the reclocked output by setting $\overline{\text{RC_BYP}}$ to logic HIGH. If $\overline{\text{RC_BYP}}$ is set LOW, the data stream will bypass the internal reclocker and the serial digital output will be a buffered version of the input.

When operating in master mode, the device will assert the $\overline{\text{RC_BYP}}$ pin HIGH only when it has successfully locked to a SMPTE input data stream, (see [Lock Detect on page 35](#)). In this case, the serial digital loop-through output will be a reclocked version of the input.

3.4.3 Serial Digital Output Mute

The GS1560A will automatically mute the serial digital loop-through output in both master and slave modes when the internal carrier_detect signal indicates an invalid serial input.

The loop-through output will also be muted in slave mode when $\text{SDO}/\overline{\text{SDO}}$ is selected as reclocked, ($\overline{\text{RC_BYP}} = \text{HIGH}$), but the lock detect block has failed to lock to the data stream, ($\text{LOCKED} = \text{LOW}$).

Table 3-1 summarizes the possible states of the serial digital loop-through output data stream.

Table 3-1: Serial Digital Loop-Through Output Status

SLAVE MODE			
SDO	$\overline{\text{CD}}$	LOCKED	$\overline{\text{RC_BYP}}$ (INPUT)
RELOCKED	LOW	HIGH	HIGH
BUFFERED	LOW	X	LOW
MUTED	LOW	LOW	HIGH
MUTED	HIGH	LOW*	X
MASTER MODE			
SDO	$\overline{\text{CD}}$	LOCKED	$\overline{\text{RC_BYP}}$ (OUTPUT)
RELOCKED	LOW	HIGH	HIGH
BUFFERED	LOW	LOW	LOW
MUTED	HIGH	LOW*	LOW

*NOTE: LOCKED = HIGH if and only if $\overline{\text{CD}} = \text{LOW}$

3.5 Serial-To-Parallel Conversion

The retimed data and phase-locked clock signals from the reclocker are fed to the serial-to-parallel converter. The function of this block is to extract 10-bit or 20-bit parallel data words from the reclocked serial data stream and present them to the SMPTE and DVB-ASI word alignment blocks simultaneously.

3.6 Modes Of Operation

The GS1560A/GS1561 has two basic modes of operation which determine how the lock detect block controls the integrated reclocker. Master mode is enabled when the application layer sets the MASTER/SLAVE pin HIGH, and slave mode is enabled when MASTER/SLAVE is set LOW.

3.6.1 Lock Detect

The lock detect block controls the center frequency of the integrated reclocker to ensure lock to the received serial digital data stream is achieved, and indicates via the LOCKED output pin that the device has detected the appropriate sync words. In Data Through mode, the detection for appropriate sync words is turned off. The LOCKED pin is an indication of analog lock.

Lock detection is a continuous process, which begins at device power up or after a system reset, and continues until the device is powered down or held in reset.

The lock detection algorithm first determines if a valid serial digital input signal has been presented to the device by sampling the internal carrier_detect signal. As described in [Carrier Detect Input on page 31](#), this signal will be LOW when a good serial digital input signal has been detected.

If the carrier_detect signal is HIGH, the serial data into the device is considered invalid, and the VCO frequency will be set to the center of the pull range. The LOCKED pin will be LOW and all outputs of the device except for the PCLK output will be muted. Instead, the PCLK output frequency will operate within +/-3% of the rates shown in [Table 3-16 of Parallel Output Clock \(PCLK\) on page 67](#).

NOTE: When the device is operating in DVB-ASI slave mode, the parallel outputs will not mute when the carrier_detect signal is HIGH. The LOCKED signal will function normally.

If a valid input signal has been detected, and the device is in master mode, the lock algorithm will enter a hunt phase where four attempts are made to detect the presence of either SMPTE TRS sync words. At each attempt, the center frequency of the reclocker will be toggled between 270Mb/s and 1.485Gb/s.

Assuming that a valid SMPTE or DVB-ASI signal has been applied to the device, asynchronous lock times will be as listed in [Table 2-2: AC Electrical Characteristics](#).

In slave mode, the application layer fixes the center frequency of the reclocker such that the lock algorithm will attempt to lock within the single data rate determined by the setting of the SD/HD pin. Asynchronous lock times are also listed in the [Table 2-2: AC Electrical Characteristics](#).

NOTE: The PCLK output will continue to operate during the lock detection process. The frequency may toggle between 148MHz and 27MHz when the 20bit/10bit pin is set LOW, or between 74MHz and 13.5MHz when 20bit/10bit is set HIGH.

For SMPTE inputs, the lock detect block will only assert the LOCKED output signal HIGH if (1) the reclocker has locked to the input data stream as indicated by the internal pll_lock signal, and (2) TRS sync words have been correctly identified.

If after four attempts lock has not been achieved, the lock detection algorithm will enter into PLL lock mode. In this mode, the reclocker will attempt to lock to the input data stream without detecting SMPTE TRS words. This unassisted process can take up to 10ms to achieve lock.

When reclocker lock as indicated by the internal pll_lock signal is achieved in this mode, one of the following will occur:

1. In slave mode, data will be passed directly to the parallel outputs without any further processing taking place and the LOCKED signal will be asserted HIGH if and only if the SMPTE_BYPASS and DVB_ASI input pins are set LOW; or
2. In master mode, the LOCKED signal will be asserted LOW, the parallel outputs will be latched to logic LOW, and the SMPTE_BYPASS output signal will also be set LOW.

3.6.2 Master Mode

Recall that the GS1560A/GS1561 is said to be in master mode when the MASTER/SLAVE input signal is set HIGH. In this case, the following three device pins become output status signals:

- $\overline{\text{SMPTE_BYPASS}}$
- $\overline{\text{SD/HD}}$
- $\overline{\text{RC_BYP}}$ (GS1560A only)

The combined setting of these pins will indicate whether the device has locked to valid SMPTE data at SD or HD rates. DVB_ASI functionality is not supported in Master mode. [Table 3-2](#) shows the possible combinations.

3.6.3 Slave Mode

The GS1560A/GS1561 is said to be in slave mode when the MASTER/ $\overline{\text{SLAVE}}$ input signal is set LOW. In this case, the device pins listed in [Master Mode on page 36](#), in addition to the DVB_ASI pin, become input control signals.

It is required that the application layer set the inputs to reflect the appropriate input data format ($\overline{\text{SMPTE_BYPASS}}$, DVB_ASI, and $\overline{\text{SD/HD}}$). If just one of these pins is configured incorrectly, the device will not lock to the input data stream, and the $\overline{\text{DATA_ERROR}}$ pin will be set LOW.

The input signals, $\overline{\text{RC_BYP}}$ (GS1560A only), allows the application layer to determine whether the serial digital loop-through output will be a reclocked or buffered version of the input, [Reclocker Bypass Control on page 34](#). [Table 3-3](#) shows the required settings for various input formats.

Table 3-2: Master Mode Output Status Signals

FORMAT	PIN SETTINGS		
	$\overline{\text{SMPTE_BYPASS}}$	$\overline{\text{SD/HD}}$	$\overline{\text{RC_BYP}}$ (GS1560A only)
HD SMPTE	HIGH	LOW	HIGH
SD SMPTE	HIGH	HIGH	HIGH
NOT SMPTE*	LOW	HIGH OR LOW	LOW

*NOTE: When the device locks to the data stream in PLL lock mode, the parallel outputs will be latched LOW, and the serial loop-through output (GS1560A only) will be a buffered version of the input.

Table 3-3: Slave Mode Input Control Signals

FORMAT	PIN SETTINGS		
	$\overline{\text{SMPTE_BYPASS}}$	DVB_ASI	$\overline{\text{SD/HD}}$
HD SMPTE	HIGH	LOW	LOW
SD SMPTE	HIGH	LOW	HIGH
DVB-ASI	LOW	HIGH	HIGH
NOT SMPTE OR DVB-ASI*	LOW	LOW	HIGH OR LOW

*NOTE: See [Data Through Mode on page 46](#) for a complete description of Data Through mode.

3.7 SMPTE Functionality

The GS1560A/GS1561 is said to be in SMPTE mode once the device has detected SMPTE TRS sync words and locked to the input data stream as described in [Lock Detect on page 35](#). The device will remain in SMPTE mode until such time that SMPTE TRS sync words fail to be detected.

The lock detect block may also drop out of SMPTE mode under the following conditions:

- $\overline{\text{RESET_TRST}}$ is asserted LOW
- $\overline{\text{CDx}}$ is HIGH
- $\overline{\text{SMPTE_BYPASS}}$ is asserted LOW in slave mode
- DVB_ASI is asserted HIGH in slave mode

TRS word detection is a continuous process and both 8-bit and 10-bit TRS words will be identified by the device in both SD and HD modes.

In master mode, the GS1560A/GS1561 sets the $\overline{\text{SMPTE_BYPASS}}$ pin HIGH to indicate that it has locked to a SMPTE input data stream. When operating in slave mode, the application layer must assert the DVB_ASI pin LOW and the $\overline{\text{SMPTE_BYPASS}}$ pin HIGH in order to enable SMPTE operation.

3.7.1 SMPTE Descrambling and Word Alignment

After serial-to-parallel conversion, the internal 10-bit or 20-bit data bus is fed to the SMPTE descramble and word alignment block. The function of this block is to carry out NRZI-to-NRZ decoding, descrambling according to SMPTE 259M or 292M, and word alignment of the data to the TRS sync words.

Word alignment occurs when two consecutive valid TRS words (SAV and EAV inclusive) with the same bit alignment have been detected.

In normal operation, re-synchronization of the word alignment process will only take place when two consecutive identical TRS word positions have been detected. When automatic or manual switch line lock handling is 'actioned', (see [Switch Line Lock Handling on page 39](#)), word alignment re-synchronization will occur on the next received TRS code word.

3.7.2 Internal Flywheel

The GS1560A/GS1561 has an internal flywheel which is used in the generation of internal / external timing signals, in the detection and correction of certain error conditions and in automatic video standards detection. It is only operational in SMPTE mode.

The flywheel consists of a number of counters and comparators operating at video pixel and video line rates. These counters maintain information about the total line length, active line length, total number of lines per field / frame, and total active lines per field / frame for the received video stream.

The flywheel 'learns' the video standard by timing the horizontal and vertical reference information contained in the TRS ID words of the received video stream. Full

synchronization of the flywheel to the received video standard therefore requires one complete video frame.

Once synchronization has been achieved, the flywheel will continue to monitor the received TRS timing information to maintain synchronization.

The FW_EN/ $\overline{\text{DIS}}$ input pin controls the synchronization mechanism of the flywheel. When this input signal is LOW, the flywheel will re-synchronize all pixel and line based counters on every received TRS ID word.

When FW_EN/ $\overline{\text{DIS}}$ is held HIGH, re-synchronization of the pixel and line based counters will only take place when a consistent synchronization error has been detected. Two consecutive video lines with identical TRS timing different to the current flywheel timing must occur to initiate re-synchronization of the counters. This provides a measure of noise immunity to internal and external timing signal generation.

The flywheel will be disabled should the LOCKED signal or the $\overline{\text{RESET_TRST}}$ signal be LOW. A LOW to HIGH transition on either signal will cause the flywheel to re-acquire synchronization on the next received TRS word, regardless of the setting of the FW_EN/ $\overline{\text{DIS}}$ pin.

3.7.3 Switch Line Lock Handling

The principal of switch line lock handling is that the switching of synchronous video sources will only disturb the horizontal timing and alignment of the stream, whereas the vertical timing remains in synchronization.

To account for the horizontal disturbance caused by a synchronous switch, it is necessary to re-synchronize the flywheel immediately after the switch has taken place. Rapid re-synchronization of the GS1560A/GS1561 to the new video standard can be achieved by controlling the flywheel using the FW_EN/ $\overline{\text{DIS}}$ pin.

At every PCLK cycle the device samples the FW_EN/ $\overline{\text{DIS}}$ pin. When a logic LOW to HIGH transition at this pin is detected anywhere within the active line, the flywheel will re-synchronize immediately to the next TRS word. This is shown in [Figure 3-2](#).

To ensure switch line lock handling, the FW_EN/ $\overline{\text{DIS}}$ signal should be LOW for a minimum of one PCLK cycle (maximum one video line) anywhere within the active portion of the line on which the switch has taken place.

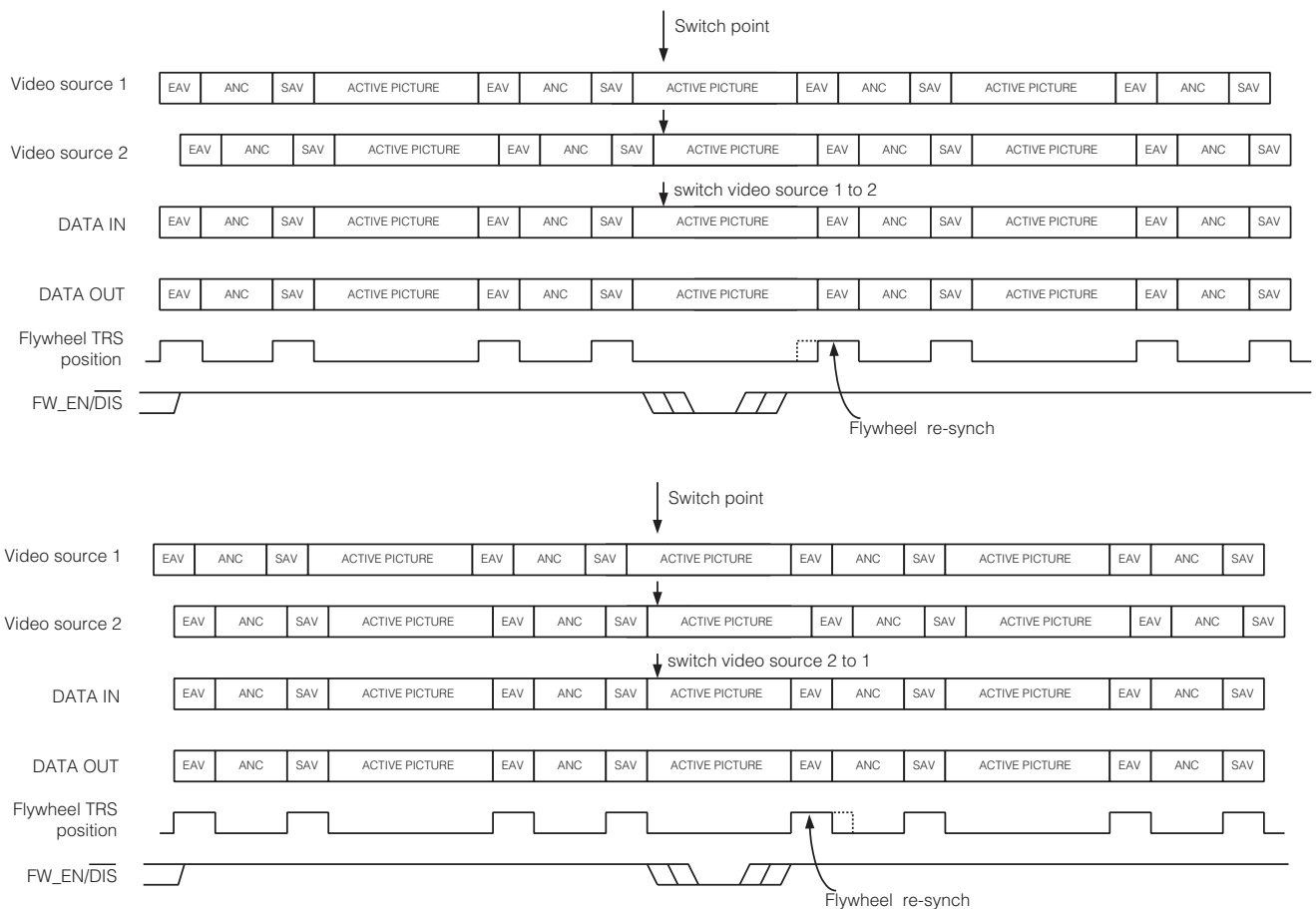

Figure 3-2: Switch Line Locking

The ability to manually re-synchronize the flywheel is also important when switching asynchronous sources or to implement other non-standardized video switching functions.

The GS1560A/GS1561 also implements automatic switch line lock handling. By utilizing the synchronous switch points defined by SMPTE RP168 for all major video standards with the automatic video standards detect function, the device automatically re-synchronizes the flywheel at the switch point.

This function will occur regardless of the setting of the FW_EN/DIS pin.

The switch line is defined as follows:

- For 525 line interlaced systems: re-sync takes place at the end of lines 10 & 273.
- For 525 line progressive systems: re-sync takes place at the end of line 10.
- For 625 line interlaced systems: re-sync takes place at the end of lines 6 & 319.
- For 625 line progressive systems: re-sync takes place at the end of line 6.
- For 750 line progressive systems: re-sync takes place at the end of line 7.
- For 1125 line interlaced systems: re-sync takes place at the end of lines 7 & 568.
- For 1125 line progressive systems: re-sync takes place at the end of line 7.

A full list of all major video standards and switching lines is shown in [Table 3-4](#).

NOTE 1: The flywheel timing will define the line count such that the line numbers shown in [Table 3-4](#) may not correspond directly to the digital line counts.

NOTE 2: Unless indicated by SMPTE 352M payload identifier packets, the GS1560A/GS1561 will not distinguish between 50/60 frames PsF and 25/30 frames interlaced for the 1125 line video systems; 24 PsF will be identified.

Table 3-4: Switch Line Position for Digital Systems

System	Video Format	Sampling	Signal Standard	Parallel Interface	Serial Interface	Switch Line No.
HD-SDTI	1920x1080 (PsF)	4:2:2	274M	274M + 348M	292M	7
	1920x1080 (2:1)	4:2:2	274M	274M + 348M	292M	7, 569
	1280x720 (1:1)	4:2:2	296M	296M + 348M	292M	7
SDTI	720x576/50 (2:1)	4:2:2	BT.656	BT.656 + 305M	259M	6, 319
	720x483/59.94 (2:1)	4:2:2	125M	125M + 305M	259M	10, 273
750	1280x720/60 (1:1)	4:2:2	296M	296M	296M	7
	1280x720/50 (1:1)	4:2:2	296M	296M	296M	7
	1280x720/30 (1:1)	4:2:2	296M	296M	296M	7
	1280x720/25 (1:1)	4:2:2	296M	296M	296M	7
	1280x720/24 (1:1)	4:2:2	296M	296M	296M	7
1125	1920x1080/30 (PsF)	4:2:2	274M + RP211	274M + RP211	292M	7
	1920x1080/25 (PsF)	4:2:2	274M + RP211	274M + RP211	292M	7
	1920x1080/24 (PsF)	4:2:2	274M + RP211	274M + RP211	292M	7
	1920x1080/60 (2:1)	4:2:2	274M + RP211	274M + RP211	292M	7, 569
	1920x1080/50 (2:1)	4:2:2	274M + RP211	274M + RP211	292M	7, 569

Table 3-4: Switch Line Position for Digital Systems (Continued)

System	Video Format	Sampling	Signal Standard	Parallel Interface	Serial Interface	Switch Line No.
525	960x483/59.94 (2:1)	4:2:2	267M	349M	292M	10, 273
	960x483/59.94 (2:1)	4:2:2	267M	267M	259M	10, 273
	720x483/59.94 (2:1)	4:4:4:4	267M	349M	292M	10, 273
	720x483/59.94 (2:1)	4:4:4:4	267M	347M	344M	10, 273
	720x483/59.94 (2:1)	4:4:4:4	267M	RP174	344M	10, 273
	720x483/59.94 (2:1)	4:4:4:4	267M	RP175	RP175	10, 273
	720x483/59.94 (2:1)	4:2:2	125M	349M	292M	10, 273
	720x483/59.94 (2:1)	4:2:2	125M	125M	259M	10, 273
	720x483/59.94 (1:1)	4:2:2	293M	349M	292M	10
	720x483/59.94 (1:1)	4:2:2	293M	347M	344M	10
	720x483/59.94 (1:1)	4:2:2	293M	293M	294M	10
	720x483/59.94 (1:1)	4:2:0	293M	349M	292M	10
	720x483/59.94 (1:1)	4:2:0	293M	293M	294M	10
	625	720x576/50 (1:1)	4:2:2	BT.1358	349M	292M
720x576/50 (1:1)		4:2:2	BT.1358	347M	344M	6
720x576/50 (1:1)		4:2:2	BT.1358	BT.1358	BT.1362	6
720x576/50 (1:1)		4:2:0	BT.1358	349M	292M	6
720x576/50 (1:1)		4:2:0	BT.1358	BT.1358	BT.1362	6
960x576/50 (2:1)		4:2:2	BT.601	349M	292M	6, 319
960x576/50 (2:1)		4:2:2	BT.601	BT.656	259M	6, 319
720x576/50 (2:1)		4:4:4:4	BT.799	349M	292M	6, 319
720x576/50 (2:1)		4:4:4:4	BT.799	347M	344M	6, 319
720x576/50 (2:1)		4:4:4:4	BT.799	BT.799	344M	6, 319
720x576/50 (2:1)		4:4:4:4	BT.799	BT.799	–	6, 319
720x576/50 (2:1)		4:2:2	BT.601	349M	292M	6, 319
720x576/50 (2:1)		4:2:2	BT.601	125M	259M	6, 319

3.7.4 HVF Timing Signal Generation

The GS1560A/GS1561 extracts critical timing parameters from either the received TRS signals ($\overline{\text{FW_EN/DIS}} = \text{LOW}$), or from the internal flywheel-timing generator ($\overline{\text{FW_EN/DIS}} = \text{HIGH}$).

Horizontal blanking period (H), vertical blanking period (V), and even / odd field (F) timing are all extracted and presented to the application layer via the H:V:F status output pins.

The H signal timing is configurable via the H_CONFIG bit of the internal IOPROC_DISABLE register as either active line based blanking, or TRS based blanking, (see [Error Correction and Insertion on page 61](#)).

Active line based blanking is enabled when the H_CONFIG bit is set LOW. In this mode, the H output is HIGH for the entire horizontal blanking period, including the EAV and SAV TRS words. This is the default H timing used by the device.

When H_CONFIG is set HIGH, TRS based blanking is enabled. In this case, the H output will be HIGH for the entire horizontal blanking period as indicated by the H bit in the received TRS ID words.

The timing of these signals is shown in [Figure 3-3](#).

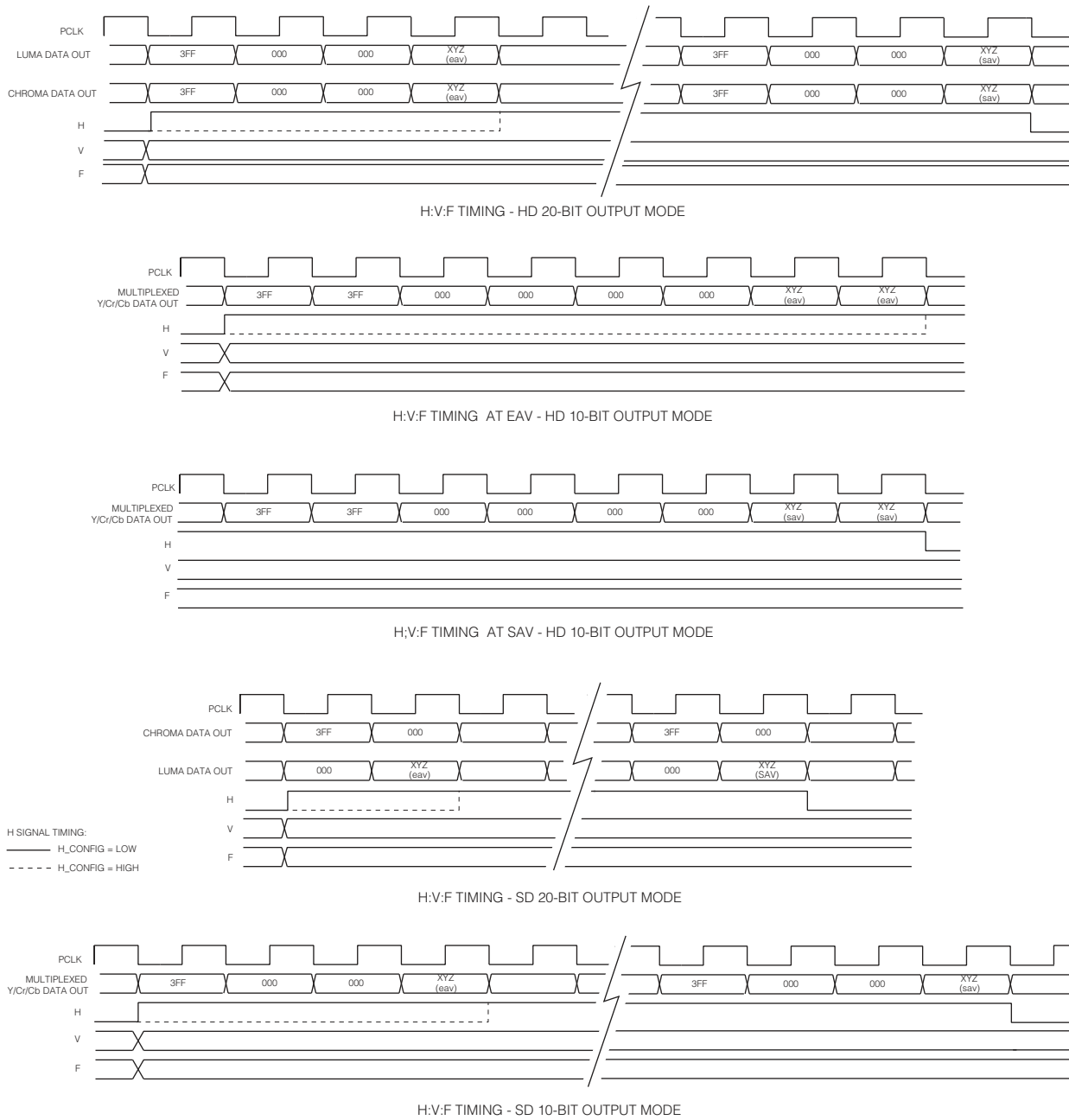

Figure 3-3: H, V, F Timing

3.8 DVB-ASI Functionality

The GS9060 conforms to DVB-ASI standard EN 50083-9:1998.

The lock detect block may drop out of DVB-ASI mode under the following conditions:

- $\overline{\text{RESET_TRST}}$ is asserted LOW
- $\overline{\text{CDx}}$ is HIGH
- $\overline{\text{SMPTE_BYPASS}}$ is asserted HIGH in slave mode
- DVB_ASI is asserted LOW in slave mode

DVB_ASI functionality is only supported in Slave mode. To operate in DVB_ASI mode, the device must be in Slave mode, and the application layer must set the $\overline{\text{SD/HD}}$ pin HIGH, in addition to setting $\overline{\text{SMPTE_BYPASS}}$ LOW and DVB_ASI HIGH.

3.8.1 Transport Packet Format

Transport packet structure shall conform to the specifications of EN/ISO/IEC 13818-1 and ETS 300 429 for Transport Stream Packets. The packet length can be 188 or 204 bytes.

3.8.2 DVB-ASI 8b/10b Decoding and Word Alignment

After serial-to-parallel conversion, the internal 10-bit data bus is fed to the DVB-ASI 8b/10b decode and word alignment block. The function of this block is to word align the data to the K28.5 sync characters, and 8b/10b decode and bit-swap the data to achieve bit alignment with the data outputs.

The extracted 8-bit data will be presented to DOUT[17:10], bypassing all internal SMPTE mode data processing.

NOTE: When operating in DVB-ASI mode, DOUT[9:0] are forced LOW.

3.8.3 Status Signal Outputs

In DVB-ASI mode, the DOUT19 and DOUT18 pins will be configured as DVB-ASI status signals SYNCOUT and WORDERR respectively.

SYNCOUT will be HIGH whenever a K28.5 sync character is present on the output. This output may be used to drive the write enable signal of an external FIFO, thus providing a means of removing the K28.5 sync characters from the data stream. Parallel DVB-ASI data may then be clocked out of the FIFO at some rate less than 27MHz. See [Figure 3-4](#).

WORDERR will be high whenever the device has detected a running disparity error or illegal code word.

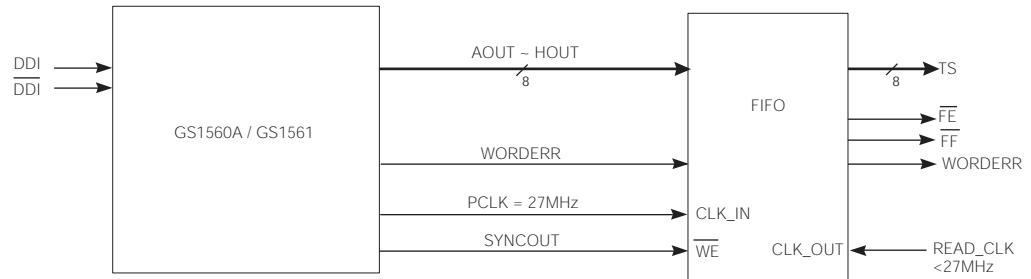

Figure 3-4: DVB-ASI FIFO Implementation Using The GS1560A

3.9 Data Through Mode

The GS1560A/GS1561 may be configured by the application layer to operate as a simple serial-to-parallel converter. In this mode, the device presents data to the output data bus without performing any decoding, descrambling or word-alignment.

Data through mode is enabled only when the $\overline{\text{MASTER/SLAVE}}$, $\overline{\text{SMPTE_BYPASS}}$, and DVB_ASI input pins are set LOW. Under these conditions, the lock detection algorithm enters PLL lock mode, (see [Lock Detect on page 35](#)), such that the device may relock data not conforming to SMPTE or DVB-ASI streams. The LOCKED pin will indicate analog lock.

When operating in master mode, the GS1560A/GS1561 will set the $\overline{\text{SMPTE_BYPASS}}$ signal to logic LOW if presented with a data stream without SMPTE TRS ID words. The LOCKED and data bus outputs will be forced LOW and the serial digital loop-through output (GS1560A only) will be a buffered version of the input.

3.10 Additional Processing Functions

The GS1560A/GS1561 contains an additional data processing block which is available in SMPTE mode only, (see [SMPTE Functionality on page 38](#)).

3.10.1 FIFO Load Pulse

To aid in the application-specific implementation of auto-phasing and line synchronization functions, the GS1560A/GS1561 will generate a FIFO load pulse to reset line-based FIFO storage.

The $\overline{\text{FIFO_LD}}$ output pin will normally be HIGH but will go LOW for one PCLK period, thereby generating a FIFO write reset signal.

The FIFO load pulse will be generated such that it is co-timed to the SAV XYZ code word presented to the output data bus. This ensures that the next PCLK cycle will correspond to the first active sample of the video line.

Figure 3-5 shows the timing relationship between the $\overline{\text{FIFO_LD}}$ signal and the output video data.

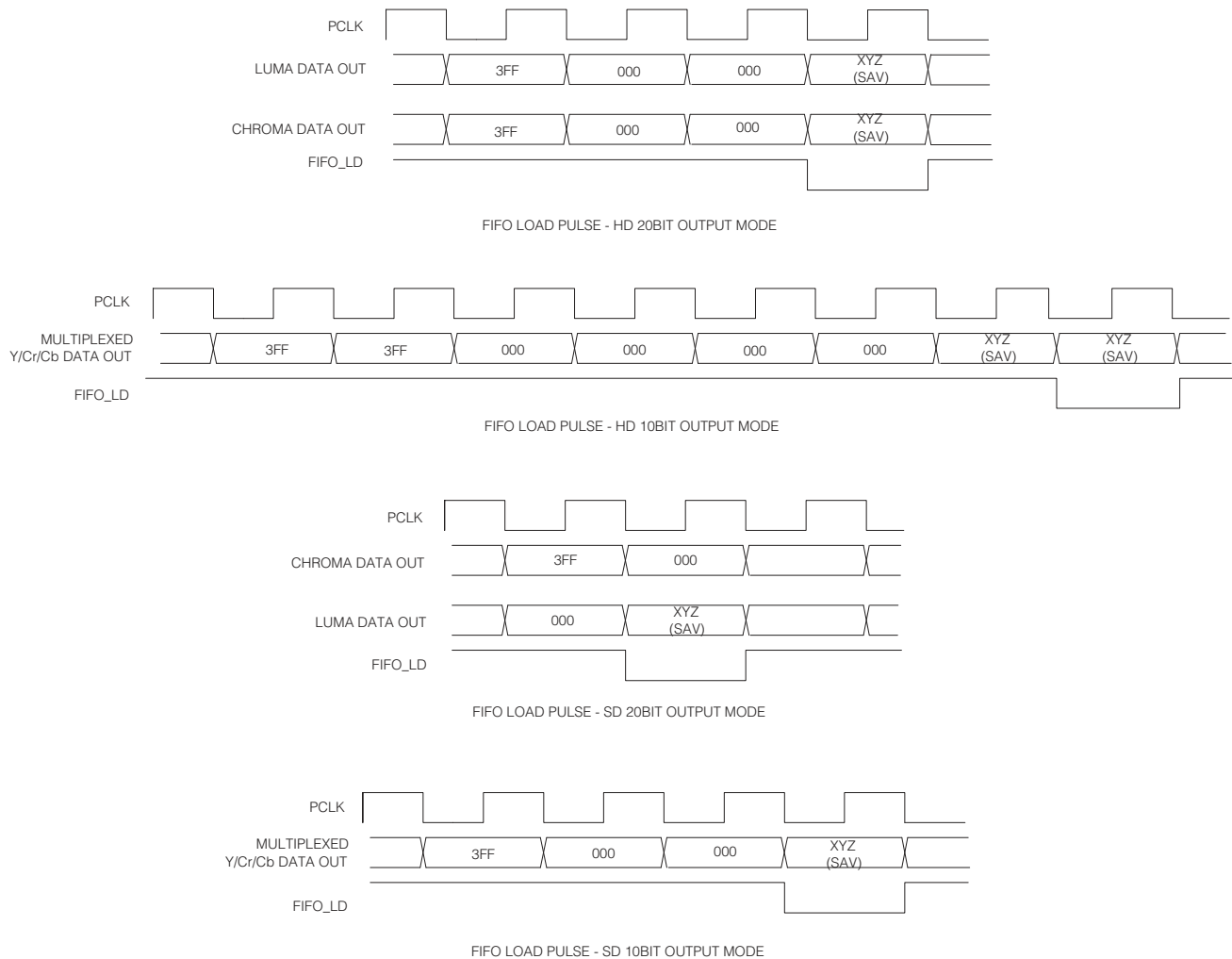

Figure 3-5: $\overline{\text{FIFO_LD}}$ Pulse Timing

3.10.2 Ancillary Data Detection and Indication

The GS1560A/GS1561 will detect all types of ancillary data in either the vertical or horizontal blanking spaces and indicate via the status signal output pins YANC and CANC the position of ancillary data in the output data stream. These status signal outputs are synchronous with PCLK and can be used as clock enables to external logic, or as write enables to an external FIFO or other memory device.

When operating in HD mode, ($SD/\overline{HD} = \text{LOW}$), the YANC signal will be HIGH whenever ancillary data is detected in the luma data stream, and the CANC signal will be HIGH whenever ancillary data is detected in the chroma data stream.

In SD mode, ($SD/\overline{HD} = \text{HIGH}$), the YANC and CANC signal operation will depend on the output data format. For 20-bit demultiplexed data, (see [Parallel Data Outputs on page 65](#)), the YANC and CANC signals will operate independently. However, for 10-bit multiplexed data, the YANC and CANC signals will both be HIGH whenever ancillary data is detected.

The signals will be HIGH from the start of the ancillary data preamble and will remain HIGH until after the ancillary data checksum.

The operation of the YANC and CANC signals is shown in [Figure 3-6](#).

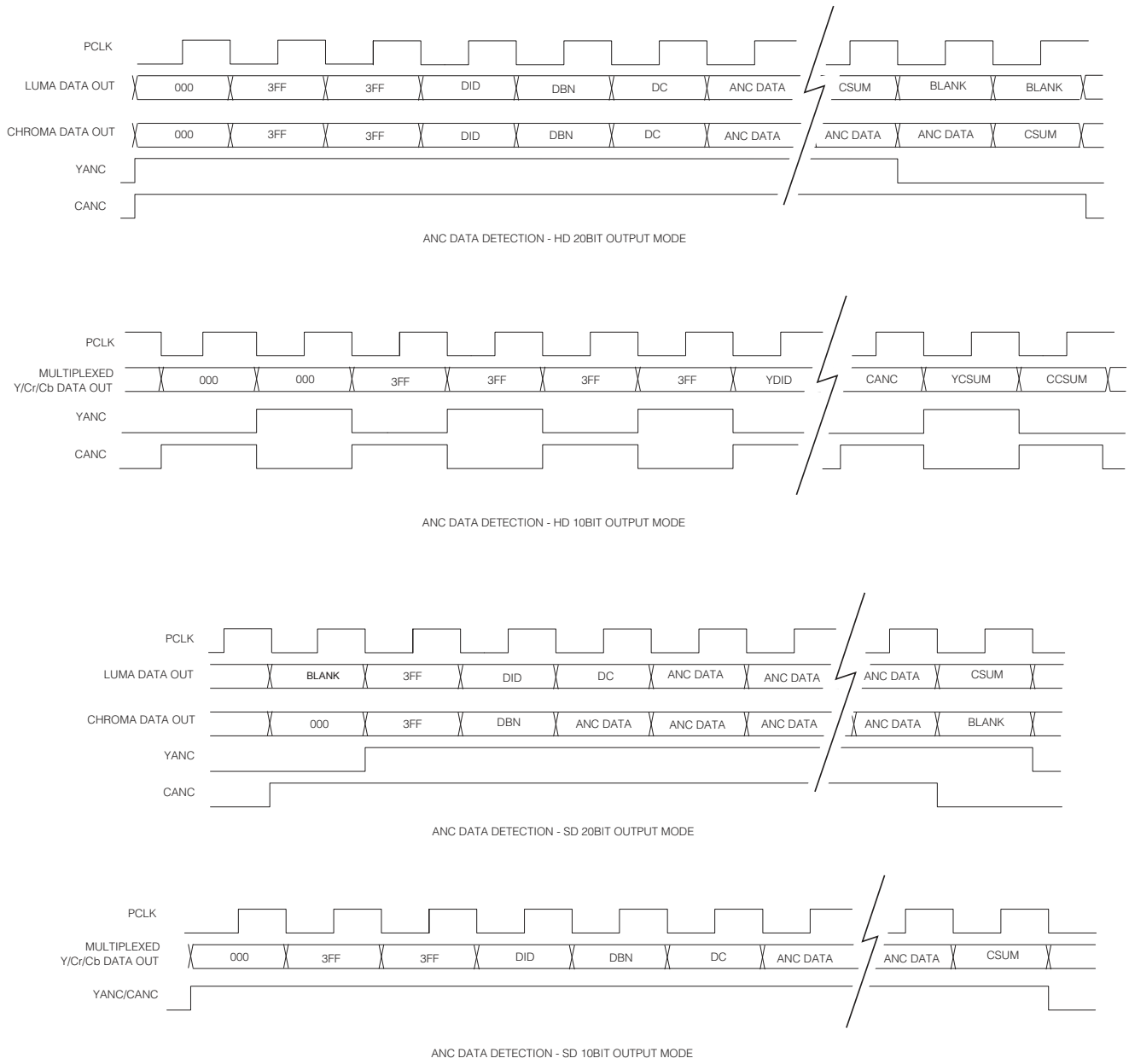

Figure 3-6: YANC and CANC Output Signal Timing

3.10.2.1 Programmable Ancillary Data Detection

Although the GS1560A/GS1561 will detect all types of ancillary data by default, it also allows the host interface to specifically program up to five different ancillary data types for detection. This is accomplished via the ANC_TYPE register (Table 3-5).

For each data type to be detected, the host interface must program the DID and/or SDID of the ancillary data type of interest. The GS1560A/GS1561 will compare the received DID and/or SDID with the programmed values and assert YANC and CANC only if an exact match is found.

If any DID or SDID value is set to zero in the ANC_TYPE register, no comparison or match will be made for that value. For example, if the DID is programmed but the SDID is set to zero, the device will detect all ancillary data types matching the DID value, regardless of the SDID.

In the case where all five DID and SDID values are set to zero, the GS1560A/GS1561 will detect all ancillary data types. This is the default setting after device reset.

Where one or more, but less than five, DID and/or SDID values have been programmed, then only those matching ancillary data types will be detected and indicated.

NOTE 1: The GS1560A/GS1561 will always detect EDH ancillary data packets for EDH error detection purposes, regardless of which DID/SDID values have been programmed for ancillary data indication, (see [EDH CRC Error Detection on page 58](#)).

NOTE 2: See SMPTE 291M for a definition of ancillary data terms.

Table 3-5: Host Interface Description for Programmable Ancillary Data Type Registers

Register Name	Bit	Name	Description	R/W	Default
ANC_TYPE1 Address: 005h	15-8	ANC_TYPE1[15:8]	Used to program the DID for ancillary data detection at the YANC and CANC output	R/W	0
	7-0	ANC_TYPE1[7:0]	Used to program the SDID for ancillary data detection at the YANC and CANC output. Should be set to zero if no SDID is present in the ancillary data packet to be detected.	R/W	0
ANC_TYPE2 Address: 006h	15-8	ANC_TYPE2[15:8]	Used to program the DID for ancillary data detection at the YANC and CANC output	R/W	0
	7-0	ANC_TYPE2[7:0]	Used to program the SDID for ancillary data detection at the YANC and CANC output. Should be set to zero if no SDID is present in the ancillary data packet to be detected.	R/W	0
ANC_TYPE3 Address: 007h	15-8	ANC_TYPE3[15:8]	Used to program the DID for ancillary data detection at the YANC and CANC output	R/W	0
	7-0	ANC_TYPE3[7:0]	Used to program the SDID for ancillary data detection at the YANC and CANC output. Should be set to zero if no SDID is present in the ancillary data packet to be detected.	R/W	0
ANC_TYPE4 Address: 008h	15-8	ANC_TYPE4[15:8]	Used to program the DID for ancillary data detection at the YANC and CANC output	R/W	0
	7-0	ANC_TYPE4[7:0]	Used to program the SDID for ancillary data detection at the YANC and CANC output. Should be set to zero if no SDID is present in the ancillary data packet to be detected.	R/W	0
ANC_TYPE5 Address: 009h	15-8	ANC_TYPE5[15:8]	Used to program the DID for ancillary data detection at the YANC and CANC output	R/W	0
	7-0	ANC_TYPE5[7:0]	Used to program the SDID for ancillary data detection at the YANC and CANC output. Should be set to zero if no SDID is present in the ancillary data packet to be detected.	R/W	0

3.10.3 SMPTE 352M Payload Identifier

The GS1560A/GS1561 can receive and detect the presence of the SMPTE 352M payload identifier ancillary data packet. This four word payload identifier packet may be used to indicate the transport mechanism, frame rate and line scanning / sampling structure.

Upon reception of this packet, the device will extract the four words describing the video format being transported and make this information available to the host interface via the four VIDEO_FORMAT_OUT registers (Table 3-6).

The VIDEO_FORMAT_OUT registers will only be updated if the received checksum is the same as the locally calculated checksum.

These registers will be cleared to zero, indicating an undefined format, if the device loses lock to the input data stream (LOCKED = LOW), or if the SMPTE_BYPASS pin is asserted LOW. This is also the default setting after device reset.

The SMPTE 352M packet should be received once per field for interlaced systems and once per frame for progressive systems. If the packet is not received for two complete video frames, the VIDEO_FORMAT_OUT registers will be cleared to zero.

Table 3-6: Host Interface Description for SMPTE 352M Payload Identifier Registers

Register Name	Bit	Name	Description	R/W	Default
VIDEO_FORMAT_OUT_B Address: 00Dh	15-8	SMPTE352M Byte 4	Data will be available in this register when Video Payload Identification Packets are detected in the data stream.	R	0
	7-0	SMPTE352M Byte 3	Data will be available in this register when Video Payload Identification Packets are detected in the data stream.	R	0
VIDEO_FORMAT_OUT_A Address: 00Ch	15-8	SMPTE352M Byte 2	Data will be available in this register when Video Payload Identification Packets are detected in the data stream.	R	0
	7-0	SMPTE352M Byte 1	Data will be available in this register when Video Payload Identification Packets are detected in the data stream.	R	0

3.10.4 Automatic Video Standard and Data Format Detection

The GS1560A/GS1561 can independently detect the input video standard and data format by using the timing parameters extracted from the received TRS ID words. This information is presented to the host interface via the VIDEO_STANDARD register (Table 3-7).

Total samples per line, active samples per line, total lines per field/frame and active lines per field/frame are also calculated and presented to the host interface via the RASTER_STRUCTURE registers (Table 3-8). These line and sample count registers are updated once per frame at the end of line 12. This is in addition to the information contained in the VIDEO_STANDARD register.

After device reset, the four RASTER_STRUCTURE registers default to zero.

3.10.4.1 Video Standard Indication

The video standard codes reported in the VD_STD[4:0] bits of the VIDEO_STANDARD register represent the SMPTE standards as shown in Table 3-9.

In addition to the 5-bit video standard code word, the VIDEO_STANDARD register also contains two status bits. The STD_LOCK bit will be set HIGH whenever the flywheel has achieved full synchronization. The INT_PROG bit will be set LOW if the detected video standard is progressive and HIGH if the detected video standard is interlaced.

The VD_STD[4:0], STD_LOCK and INT_PROG bits of the VIDEO_STANDARD register will default to zero after device reset. The VD_STD[4:0] and INT_PROG bits will also default to zero if the device loses lock to the input data stream, (LOCKED = LOW), or if the SMPTE_BYPASS pin is asserted LOW. The STD_LOCK bit will retain its previous value if the input is removed.

Table 3-7: Host Interface Description for Video Standard and Data Format Register

Register Name	Bit	Name	Description	R/W	Default
VIDEO_STANDARD Address: 004h	15	–	Not Used.	–	–
	14-10	VD_STD[4:0]	Video Data Standard (see Table 3-9).	R	0
	9	INT_PROG	Interlace/Progressive: Set LOW if detected video standard is PROGRESSIVE and is set HIGH if it is INTERLACED.	R	0
	8	STD_LOCK	Standard Lock: Set HIGH when flywheel has achieved full synchronization.	R	0
	7-4	CDATA_FORMAT[3:0]	Chroma Data Format. Set HIGH in SD mode. Indicates chroma data format in HD mode (see Table 3-10).	R	F _h
	3-0	YDATA_FORMAT[3:0]	Luma Data Format. Indicates Luma data format in HD mode and data format in SD mode (see Table 3-10).	R	F _h

Table 3-8: Host Interface Description for Raster Structure Registers

Register Name	Bit	Name	Description	R/W	Default
RASTER_STRUCTURE1 Address: 00Eh	15-12	–	Not Used.	–	–
	11-0	RASTER_STRUCTURE1[11:0]	Words Per Active Line.	R	0
RASTER_STRUCTURE2 Address: 00Fh	15-12	–	Not Used.	–	–
	11-0	RASTER_STRUCTURE2[11:0]	Words Per Total Line.	R	0
RASTER_STRUCTURE3 Address: 010h	15-11	–	Not Used.	–	–
	10-0	RASTER_STRUCTURE3[10:0]	Total Lines Per Frame.	R	0
RASTER_STRUCTURE4 Address: 011h	15-11	–	Not Used.	–	–
	10-0	RASTER_STRUCTURE4[10:0]	Active Lines Per Field.	R	0

Table 3-9: Supported Video Standards

VD_STD[4:0]	SMPTE Standard	Video Format	Length of HANC	Length of Active Video	Total Samples	SMPTE352M Lines
00h	296M (HD)	1280x720/60 (1:1)	358	1280	1650	13
01h	296M (HD)	1280x720/60 (1:1) - EM	198	1440	1650	13
02h	296M (HD)	1280x720/30 (1:1)	2008	1280	3300	13
03h	296M (HD)	1280x720/30 (1:1) - EM	408	2880	3300	13
04h	296M (HD)	1280x720/50 (1:1)	688	1280	1980	13
05h	296M (HD)	1280x720/50 (1:1) - EM	240	1728	1980	13
06h	296M (HD)	1280x720/25 (1:1)	2668	1280	3960	13
07h	296M (HD)	1280x720/25 (1:1) - EM	492	3456	3960	13
08h	296M (HD)	1280x720/24 (1:1)	2833	1280	4125	13
09h	296M (HD)	1280x720/24 (1:1) - EM	513	3600	4125	13
0Ah	274M (HD)	1920x1080/60 (2:1) or 1920x1080/30 (PsF)	268	1920	2200	10, 572
0Bh	274M (HD)	1920x1080/30 (1:1)	268	1920	2200	18
0Ch	274M (HD)	1920x1080/50 (2:1) or 1920x1080/25 (PsF)	708	1920	2640	10, 572
0Dh	274M (HD)	1920x1080/25 (1:1)	708	1920	2640	18
0Eh	274M (HD)	1920x1080/25 (1:1) - EM	324	2304	2640	18
0Fh	274M (HD)	1920x1080/25 (PsF) - EM	324	2304	2640	10, 572
10h	274M (HD)	1920x1080/24 (1:1)	818	1920	2750	18
11h	274M (HD)	1920x1080/24 (PsF)	818	1920	2750	10, 572
12h	274M (HD)	1920x1080/24 (1:1) - EM	338	2400	2750	18
13h	274M (HD)	1920x1080/24 (PsF) - EM	338	2400	2750	10, 572
14h	295M (HD)	1920x1080/50 (2:1)	444	1920	2376	10, 572
15h	260M (HD)	1920x1035/60 (2:1)	268	1920	2200	10, 572
16h	125M (SD)	1440x487/60 (2:1) (Or dual link progressive)	268	1440	1716	13, 276
17h	125M (SD)	1440x507/60 (2:1)	268	1440	1716	13, 276
19h	125M (SD)	525-line 487 generic	-	-	1716	13, 276
1Bh	125M (SD)	525-line 507 generic	-	-	1716	13, 276

Table 3-9: Supported Video Standards (Continued)

VD_STD[4:0]	SMPTE Standard	Video Format	Length of HANC	Length of Active Video	Total Samples	SMPTE352M Lines
18h	ITU-R BT.656 (SD)	1440x576/50 (2:1) (Or dual link progressive)	280	1440	1728	9, 322
1Ah	ITU-R BT.656 (SD)	625-line generic (EM)	–	–	1728	9, 322
1Dh	Unknown HD	–	–	–	–	–
1Eh	Unknown SD	–	–	–	–	–
1Ch, 1Fh	Reserved	–	–	–	–	–

3.10.4.2 Data Format Indication

The luma and chroma data format codes will be reported in the YDATA_FORMAT[3:0] and CDATA_FORMAT[3:0] bits of the VIDEO_STANDARD register when the device is operating in HD mode, (SD/ $\overline{\text{HD}}$ = LOW).

In SD or DVB-ASI mode, the data format code will only appear in the YDATA_FORMAT[3:0] bits. The CDATA_FORMAT[3:0] bits will be set to 'F_h'. These codes represent the data formats listed in Table 3-10.

The YDATA_FORMAT[3:0] and CDATA_FORMAT[3:0] bits of the VIDEO_STANDARD register will default to 'F_h' after device reset. These bits will also default to 'F_h' if the device loses lock to the input data stream, (LOCKED = LOW), or if Data-Through mode is enabled, (see [Data Through Mode on page 46](#)).

Table 3-10: Data Format Codes

YDATA_FORMAT[3:0] or CDATA_FORMAT[3:0]	Data Format	Applicable Standards
0h	SDTI DVCPRO - No ECC	SMPTE 321M
1h	SDTI DVCPRO - ECC	SMPTE 321M
2h	SDTI DVCAM	SMPTE 322M
3h	SDTI CP	SMPTE 326M
4h	Other SDTI fixed block size	–
5h	Other SDTI variable block size	–
6h	SDI	–
7h	DVB-ASI	–
8h	TDM data	SMPTE 346M
9h ~ Eh	Reserved	–
Fh	Unknown data format	–

3.10.5 Error Detection and Indication

The GS1560A/GS1561 contains a number of error detection functions to enhance operation of the device when operating in SMPTE mode. These functions, (except lock error detection), will not be available in either DVB-ASI or Data-Through operating modes. See [DVB-ASI Functionality on page 45](#) and [Data Through Mode on page 46](#).

The device maintains an error status register at address 001_h called ERROR_STATUS (Table 3-11). Each type of error has a specific flag or bit in this register which is set HIGH whenever that error is detected.

The ERROR_STATUS register will be cleared at the start of each video field or when read by the host interface, whichever condition occurs first.

All bits of the ERROR_STATUS register except the LOCK_ERR bit will also be cleared if a change in the video standard is detected, or under the following conditions:

- $\overline{\text{RESET_TRST}}$ is held LOW
- LOCKED is asserted LOW
- $\overline{\text{SMPTE_BYPASS}}$ is asserted LOW in slave mode

In addition to the ERROR_STATUS register, a register called ERROR_MASK (Table 3-12) is included which allows the host interface to select the specific error conditions that will be detected. There is one bit in the ERROR_MASK register for each type of error represented in the ERROR_STATUS register.

The bits of the ERROR_MASK register will default to '0' after device reset, thus enabling all error types to be detected. The host interface may disable individual error detection by setting the corresponding bit HIGH in this register.

Error conditions are also indicated to the application layer via the status signal pin $\overline{\text{DATA_ERROR}}$. This output pin is a logical 'OR'ing of each error status flag stored in the ERROR_STATUS register. $\overline{\text{DATA_ERROR}}$ is normally HIGH, but will be set LOW by the device when an error condition that has not been masked is detected.

Table 3-11: Host Interface Description for Error Status Register

Register Name	Bit	Name	Description	R/W	Default
ERROR_STATUS Address: 001h	15-11	–	Not Used.	–	–
	10	VD_STD_ERR	Video Standard Error Flag. Set HIGH when a mismatch between the received SMPTE352M packets and the calculated video standard occurs.	R	0
	9	FF_CRC_ERR	Full Field CRC Error Flag. Set HIGH in SD mode when a Full Field (FF) CRC mismatch has been detected in Field 1 or 2.	R	0
	8	AP_CRC_ERR	Active Picture CRC Error Flag. Set HIGH in SD mode when an Active Picture (AP) CRC mismatch has been detected in Field 1 or 2.	R	0
	7	LOCK_ERR	Lock Error Flag. Set HIGH whenever the LOCK pin is LOW (indicating the device not correctly locked).	R	0
	6	CCS_ERR	Chroma Checksum Error Flag. Set HIGH when ancillary data packet checksum error has been detected in the C channel.	R	0
	5	YCS_ERR	Luma Checksum Error Flag. Set HIGH when ancillary data packet checksum error has been detected in the Y channel.	R	0
	4	CCRC_ERR	Chroma CRC Error Flag. Set HIGH in HD mode when a mismatch occurs between the calculated and received CRC values in the C channel.	R	0
	3	YCRC_ERR	Luma CRC Error Flag. Set HIGH in HD mode when a mismatch occurs between the calculated and received CRC values in the Y channel.	R	0
	2	LNUM_ERR	Line Number Error Flag. Set HIGH in HD mode when a mismatch occurs between the calculated and received line numbers.	R	0
1	SAV_ERR	Start of Active Video Error Flag. Set HIGH when TRS errors are detected in either 8-bit or 10-bit TRS words. In HD mode only Y channel TRS codes will be checked. FW_EN/DIS must be set HIGH.	R	0	
0	EAV_ERR	End of Active Video Error Flag. Set HIGH when TRS errors are detected in either 8-bit or 10-bit TRS words. In HD mode only Y channel TRS codes will be checked. FW_EN/DIS must be set HIGH.	R	0	

Table 3-12: Host Interface Description for Error Mask Register

Register Name	Bit	Name	Description	R/W	Default
ERROR_MASK Address: 01Ah	15-11	–	Not Used.	–	–
	10	VD_STD_ERR_MASK	Video Standard Error Flag Mask bit.	R/W	0
	9	FF_CRC_ERR_MASK	Full Field CRC Error Flag Mask bit.	R/W	0
	8	AP_CRC_ERR_MASK	Active Picture CRC Error Flag Mask bit.	R/W	0
	7	LOCK_ERR_MASK	Lock Error Flag Mask bit.	R/W	0
	6	CCS_ERR_MASK	Chroma Checksum Error Flag Mask bit.	R/W	0
	5	YCS_ERR_MASK	Luma Checksum Error Flag Mask bit.	R/W	0
	4	CCRC_ERR_MASK	Chroma CRC Error Flag Mask bit.	R/W	0
	3	YCRC_ERR_MASK	Luma CRC Error Flag Mask bit.	R/W	0
	2	LNUM_ERR_MASK	Line Number Error Flag Mask bit.	R/W	0
	1	SAV_ERR_MASK	Start of Active Video Error Flag Mask bit.	R/W	0
	0	EAV_ERR_MASK	End of Active Video Error Flag Mask bit.	R/W	0

3.10.5.1 Video Standard Error Detection

If a mismatch between the received SMPTE 352M packets and the calculated video standard occurs, the GS1560A/GS1561 will indicate a video standard error by setting the VD_STD_ERR bit of the ERROR_STATUS register HIGH.

3.10.5.2 EDH CRC Error Detection

The GS1560A/GS1561 calculates Full Field (FF) and Active Picture (AP) CRC words according to SMPTE RP165 in support of Error Detection and Handling packets in SD signals.

These calculated CRC values are compared with the received CRC values. If a mismatch is detected, the error is flagged in the AP_CRC_ERR and/or FF_CRC_ERR bits of the ERROR_STATUS register. These two flags are shared between fields 1 and 2.

The AP_CRC_ERR bit will be set HIGH when an active picture CRC mismatch has been detected in field 1 or 2. The FF_CRC_ERR bit will be set HIGH when a full field CRC mismatch has been detected in field 1 or 2.

EDH CRC errors will only be indicated when the device is operating in SD mode (SD/\overline{HD} = HIGH), and when the device has correctly received EDH packets.

SMPTE RP165 specifies the calculation ranges and scope of EDH data for standard 525 and 625 component digital interfaces. The GS1560A/GS1561 will utilize these standard ranges by default.

If the received video format does not correspond to 525 or 625 digital component video standards as determined by the flywheel pixel and line counters, then one of two schemes for determining the EDH calculation ranges will be employed:

1. Ranges will be based on the line and pixel ranges programmed by the host interface; or
2. In the absence of user-programmed calculation ranges, ranges will be determined from the received TRS timing information.

The registers available to the host interface for programming EDH calculation ranges include active picture and full field line start and end positions for both fields. Table 3-13 shows the relevant registers, which default to '0' after device reset.

If any or all of these register values are zero, then the EDH CRC calculation ranges will be determined from the flywheel generated H signal. The first active and full field pixel will always be the first pixel after the SAV TRS code word. The last active and full field pixel will always be the last pixel before the start of the EAV TRS code words.

Table 3-13: Host Interface Description for EDH Calculation Range Registers

Register Name	Bit	Name	Description	R/W	Default
AP_LINE_START_F0 Address: 012h	15-10	–	Not Used.	–	–
	9-0	AP_LINE_START_F0[9:0]	Field 0 Active Picture start line data used to set EDH calculation range outside of SMPTE RP 165 values.	R/W	0
AP_LINE_END_F0 Address: 013h	15-10	–	Not Used.	–	–
	9-0	AP_LINE_END_F0[9:0]	Field 0 Active Picture end line data used to set EDH calculation range outside of SMPTE RP 165 values.	R/W	0
AP_LINE_START_F1 Address: 014h	15-10	–	Not Used.	–	–
	9-0	AP_LINE_START_F1[9:0]	Field 1 Active Picture end line data used to set EDH calculation range outside of SMPTE RP 165 values.	R/W	0
AP_LINE_END_F1 Address: 015h	15-10	–	Not Used.	–	–
	9-0	AP_LINE_END_F1[9:0]	Field 1 Active Picture end line data used to set EDH calculation range outside of SMPTE RP 165 values.	R/W	0
FF_LINE_START_F0 Address: 016h	15-10	–	Not Used.	–	–
	9-0	FF_LINE_START_F0[9:0]	Field 0 Full Field start line data used to set EDH calculation range outside of SMPTE RP 165 values.	R/W	0
FF_LINE_END_F0 Address: 017h	15-10	–	Not Used.	–	–
	9-0	FF_LINE_END_F0[9:0]	Field 0 Full Field start line data used to set EDH calculation range outside of SMPTE RP 165 values.	R/W	0
FF_LINE_START_F1 Address: 018h	15-10	–	Not Used.	–	–
	9-0	FF_LINE_START_F1[9:0]	Field 1 Full Field start line data used to set EDH calculation range outside of SMPTE RP 165 values.	R/W	0

Table 3-13: Host Interface Description for EDH Calculation Range Registers (Continued)

Register Name	Bit	Name	Description	R/W	Default
FF_LINE_END_F1 Address: 019h	15-10	–	Not Used.	–	–
	9-0	FF_LINE_END_F1[9:0]	Field 1 Full Field end line data used to set EDH calculation range outside of SMPTE RP 165 values.	R/W	0

3.10.5.3 Lock Error Detection

The LOCKED pin of the GS1560A/GS1561 indicates the lock status of the reclocker and lock detect blocks of the device. Only when the LOCKED pin is asserted HIGH has the device correctly locked to the received data stream, (see [Lock Detect on page 35](#)).

The GS1560A/GS1561 will also indicate lock error to the host interface when LOCKED = LOW by setting the LOCK_ERR bit in the ERROR_STATUS register HIGH.

3.10.5.4 Ancillary Data Checksum Error Detection

The GS1560A/GS1561 will calculate checksums for all received ancillary data and compare the calculated values to the received checksum words. If a mismatch is detected, the error is flagged in the CCS_ERR and/or YCS_ERR bits of the ERROR_STATUS register.

When operating in HD mode, (SD/\overline{HD} = LOW), the device will make comparisons on both the Y and C channels separately. If an error condition in the Y channel is detected, the YCS_ERR bit will be set HIGH. If an error condition in the C channel is detected, the CCS_ERR bit will be set HIGH.

When operating in SD mode, (SD/\overline{HD} = HIGH), only the YCS_ERR bit will be set HIGH when checksum errors are detected.

Although the GS1560A/GS1561 will calculate and compare checksum values for all ancillary data types by default, the host interface may program the device to check only certain types of ancillary data checksums.

This is accomplished via the ANC_TYPE register as described in [Programmable Ancillary Data Detection on page 50](#).

3.10.5.5 Line Based CRC Error Detection

The GS1560A/GS1561 will calculate line based CRC words for HD video signals for both the Y and C data channels. These calculated CRC values are compared with the received CRC values and any mismatch is flagged in the YCRC_ERR and/or CCRC_ERR bits of the ERROR_STATUS register.

Line based CRC error flags will only be generated when the device is operating in HD mode, (SD/\overline{HD} = LOW).

If a CRC error is detected in the Y channel, the YCRC_ERR bit in the error status register will be set HIGH. If a CRC error is detected in the C channel, the CCRC_ERR bit in the error status register is set HIGH. Y and C CRC errors will also be generated if CRC values are not received.

3.10.5.6 HD Line Number Error Detection

When operating in HD mode, the GS1560A/GS1561 will calculate line numbers based on the timing generated by the internal flywheel. These calculated line numbers are compared with the received line numbers for the Y channel data and any mismatch is flagged in the LNUM_ERR bit of the ERROR_STATUS.

Line number errors will also be generated if line number values are not received.

3.10.5.7 TRS Error Detection

TRS errors flags are generated by the GS1560A/GS1561 when:

1. The received TRS timing does not correspond to the internal flywheel timing; or
2. The received TRS hamming codes are incorrect.

Both 8-bit and 10-bit SAV and EAV TRS words are checked for timing and data integrity errors. These are flagged via the SAV_ERR and/or EAV_ERR bits of the ERROR_STATUS register.

Timing-based TRS errors will only be generated if the FW_EN/\overline{DIS} pin is set HIGH.

NOTE: In HD mode, (SD/\overline{HD} = LOW), only the Y channel TRS codes will be checked for errors.

3.10.6 Error Correction and Insertion

In addition to signal error detection and indication, the GS1560A/GS1561 may also correct certain types of errors by inserting corrected code words, checksums and CRC values into the data stream. These features are only available in SMPTE mode and IOPROC_EN/ \overline{DIS} must be set HIGH. Individual correction features may be enabled or disabled via the IOPROC_DISABLE register (Table 3-14).

All of the IOPROC_DISABLE register bits default to '0' after device reset, enabling all of the processing features. To disable any individual error correction feature, the host interface must set the corresponding bit HIGH in the IOPROC_DISABLE register.

Table 3-14: Host Interface Description for Internal Processing Disable Register

Register Name	Bit	Name	Description	R/W	Default
IOPROC_DISABLE Address: 000h	15-9	–	Not Used.	–	–
	8	H_CONFIG	Horizontal sync timing output configuration. Set LOW for active line blanking timing. Set HIGH for H blanking based on the H bit setting of the TRS words. See Figure 3-2 .		0
	7-6	–	Not Used.	–	–
	5	ILLEGAL_REMAP	Illegal Code re-mapping. Correction of illegal code words within the active picture. Set HIGH to disable. The IOPROC_EN/DIS pin must be set HIGH.	R/W	0
	4	EDH_CRC_INS	Error Detection & Handling (EDH) Cyclical Redundancy Check (CRC) error correction insertion. In SD mode set HIGH to disable. The IOPROC_EN/DIS pin must be set HIGH.	R/W	0
	3	ANC_CSUM_INS	Ancillary Data Check-sum insertion. Set HIGH to disable. The IOPROC_EN/DIS pin must be set HIGH.	R/W	0
	2	CRC_INS	Y and C line based CRC insertion. In HD mode, inserts line based CRC words in both the Y and C channels. Set HIGH to disable. The IOPROC_EN/DIS pin must be set HIGH.	R/W	0
	1	LNUM_INS	Y and C line number insertion. In HD mode set HIGH to disable. The IOPROC_EN/DIS pin must be set HIGH.	R/W	0
	0	TRS_INS	Timing Reference Signal Insertion. Set HIGH to disable. The IOPROC_EN/DIS pin must be set HIGH.	R/W	0

3.10.6.1 Illegal Code Remapping

If the ILLEGAL_REMAP bit of the IOPROC_DISABLE register is set LOW, the GS1560A will remap all codes within the active picture between the values of 3FCh and 3FFh to 3FBh. All codes within the active picture area between the values of 000h and 003h will be re-mapped to 004h.

In addition, 8-bit TRS and ancillary data preambles will be remapped to 10-bit values if this feature is enabled.

3.10.6.2 EDH CRC Error Correction

The GS1560A/GS1561 will generate and insert active picture and full field CRC words into the EDH data packets received by the device. This feature is only available in SD mode and is enabled by setting the EDH_CRC_INS bit of the IOPROC_DISABLE register LOW.

EDH CRC calculation ranges are described in [EDH CRC Error Detection on page 58](#).

NOTE: Although the GS1560A/GS1561 will modify and insert EDH CRC words and EDH packet checksums, EDH error flags will not be updated by the device.

3.10.6.3 Ancillary Data Checksum Error Correction

When ancillary data checksum error correction and insertion is enabled, the GS1560A/GS1561 will generate and insert ancillary data checksums for all ancillary data words by default. Where user specified ancillary data has been programmed into the device, (see [Programmable Ancillary Data Detection on page 50](#)), only the checksums for the programmed ancillary data types will be corrected.

This feature is enabled when the ANC_CSUM_INS bit of the IOPROC_DISABLE register is set LOW.

3.10.6.4 Line Based CRC Correction

The GS1560A/GS1561 will generate and insert line based CRC words into both the Y and C channels of the data stream. This feature is only available in HD mode and is enabled by setting the CRC_INS bit of the IOPROC_DISABLE register LOW.

3.10.6.5 HD Line Number Error Correction

In HD mode, the GS1560A/GS1561 will calculate and insert line numbers into the Y and C channels of the output data stream.

Line number generation is in accordance with the relevant HD video standard as determined by the device, (see [Automatic Video Standard and Data Format Detection on page 52](#)).

This feature is enabled when SD/\overline{HD} = LOW, and the LNUM_INS bit of the IOPROC_DISABLE register is set LOW.

3.10.6.6 TRS Error Correction

When TRS error correction and insertion is enabled, the GS1560A/GS1561 will generate and insert 10-bit TRS code words as required.

TRS word generation will be performed in accordance with the timing parameters generated by the flywheel to provide an element of noise immunity. As a result, TRS correction will only take place if the flywheel is enabled, (FW_EN/\overline{DIS} = HIGH).

In addition, the TRS_INS bit of the IOPROC_DISABLE register must be set LOW.

3.10.7 EDH Flag Detection

As described in [EDH CRC Error Detection on page 58](#), the GS1560A/GS1561 can detect EDH packets in the received data stream. The EDH flags for ancillary data, active picture and full field areas are extracted from the detected EDH packets and placed in the EDH_FLAG register of the device ([Table 3-15](#)).

One set of flags is provided for both fields 1 and 2. Field 1 flag data will be overwritten by field 2 flag data.

The EDH_FLAG register may be read by the host interface at any time during the received frame except on the lines defined in SMPTE RP165 where these flags are updated.

NOTE 1: By programming the ANC_TYPE1 register (005h) with the DID word for EDH ancillary packets, the application layer may detect a high-to-low transition on either the YANC or CANC output pin of the GS1560A/GS1561 to determine (a) when EDH packets have been received by the device, and (b) when the EDH_FLAG register can be read by the host interface. See [Ancillary Data Detection and Indication on page 48](#) for more information on ancillary data detection and indication.

NOTE 2: The bits of the EDH_FLAG register are sticky and will not be cleared by a read operation. If the GS1560A/GS1561 is decoding a source containing EDH packets, where EDH flags may be set, and the source is replaced by one without EDH packets, the EDH_FLAG register will not be cleared.

NOTE 3: The GS1560A/GS1561 will detect EDH flags, but will not update the flags if an EDH CRC error is detected. Gennum's GS1532 Multi-Rate Serializer allows the host to individually set EDH flags.

Table 3-15: Host Interface Description for EDH Flag Register

Register Name	Bit	Name	Description	R/W	Default
EDH_FLAG Address: 003h	15	–	Not Used.	–	–
	14	ANC-UES out	Ancillary Unknown Error Status Flag.	R	0
	13	ANC-IDA out	Ancillary Internal device error Detected Already Flag.	R	0
	12	ANC-IDH out	Ancillary Internal device error Detected Here Flag.	R	0
	11	ANC-EDA out	Ancillary Error Detected Already Flag.	R	0
	10	ANC-EDH out	Ancillary Error Detected Here Flag.	R	0
	9	FF-UES out	Full Field Unknown Error Status Flag.	R	0
	8	FF-IDA out	Full Field Internal device error Detected Already Flag.	R	0
	7	FF-IDH out	Full Field Internal device error Detected Here Flag.	R	0
	6	FF-EDA out	Full Field Error Detected Already Flag.	R	0
	5	FF-EDH out	Full Field Error Detected Here Flag.	R	0
	4	AP-UES out	Active Picture Unknown Error Status Flag.	R	0
	3	AP-IDA out	Active Picture Internal device error Detected Already Flag.	R	0
	2	AP-IDH out	Active Picture Internal device error Detected Here Flag.	R	0
	1	AP-EDA out	Active Picture Error Detected Already Flag.	R	0
	0	AP-EDH out	Active Picture Error Detected Here Flag.	R	0

3.11 Parallel Data Outputs

Data outputs leave the device on the rising edge of PCLK as shown in Figure 3-7 and Figure 3-8.

The data may be scrambled or unscrambled, framed or unframed, and may be presented in 10-bit or 20-bit format. The output data bus width is controlled independently from the internal data bus width by the 20bit/10bit input pin.

Likewise, the output data format is defined by the setting of the external $\overline{\text{SD/HD}}$, $\overline{\text{SMPTE_BYPASS}}$ and $\overline{\text{DVB_ASI}}$ pins. Recall that in slave mode, these pins are set by the application layer as inputs to the device. In master mode, however, the GS1560A sets the $\overline{\text{SD/HD}}$ and $\overline{\text{SMPTE_BYPASS}}$ pins as output status signals.

3.11.1 Parallel Data Bus Buffers

The parallel data outputs of the GS1560A/GS1561 are driven by high-impedance buffers which support both LVTTTL and LVCMOS levels. These buffers use a separate power supply of +3.3V DC supplied via the IO_VDD and IO_GND pins.

All output buffers, including the PCLK output, may be driven to a high-impedance state if the $\overline{\text{RESET_TRST}}$ signal is asserted LOW.

Note that the timing characteristics of the parallel data output buffers are optimized for 10-bit HD operation. As shown in Figure 3-7, the output data hold time for HD is 1.5ns.

Due to this optimization, however, the output data hold time for SD data is so small that the rising edge of the PCLK is nearly incident with the data transition. To improve output hold time at SD rates, the PCLK output is inverted in SD mode, ($\overline{\text{SD/HD}} = \text{HIGH}$). This is shown in Figure 3-8.

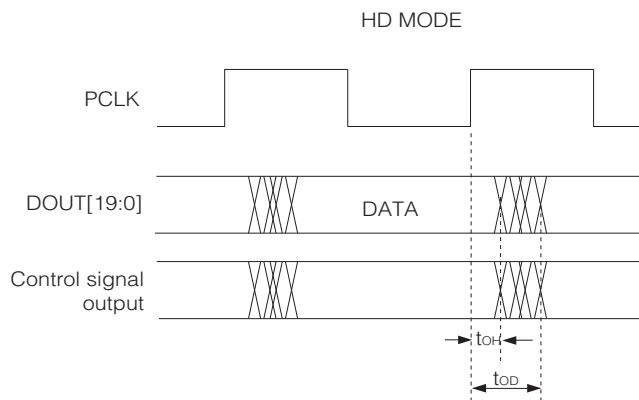

Figure 3-7: HD PCLK to Data Timing

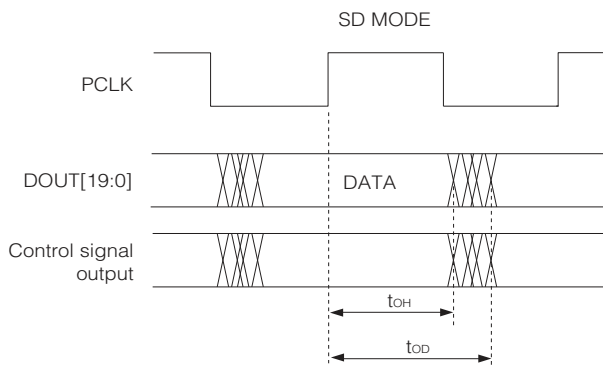

Figure 3-8: SD PCLK to Data Timing

3.11.2 Parallel Output in SMPTE Mode

When the device is operating in SMPTE mode, (see [SMPTE Functionality on page 38](#)), both SD and HD data may be presented to the output bus in either multiplexed or demultiplexed form depending on the setting of the 20bit/10bit input pin.

In 20-bit mode, (20bit/10bit = HIGH), the output data will be word aligned, demultiplexed luma and chroma data. Luma words will always appear on DOUT[19:10] while chroma words will occupy DOUT[9:0].

In 10-bit mode, (20bit/10bit = LOW), the output data will be word aligned, multiplexed luma and chroma data. The data will be presented on DOUT[19:10], and the device will force DOUT[9:0] LOW.

3.11.3 Parallel Output in DVB-ASI Mode

When operating in DVB-ASI mode, (see [DVB-ASI Functionality on page 45](#)), the GS1560A/GS1561 automatically configures the output port for 10-bit operation regardless of the setting of the 20bit/10bit pin.

The extracted 8-bit data words will be presented on DOUT[17:10] such that DOUT17 = HOUT is the most significant bit of the decoded transport stream data and DOUT10 = AOUT is the least significant bit.

In addition, DOUT19 and DOUT18 will be configured as the DVB-ASI status signals SYNCOUT and WORDERR respectively. See [Status Signal Outputs on page 46](#) for a description of these DVB-ASI specific output signals.

DOUT[9:0] will be forced LOW when the GS1560A/GS1561 is operating in DVB-ASI mode.

3.11.4 Parallel Output in Data-Through Mode

When operating in Data-Through mode, (see [Data Through Mode on page 46](#)), the GS1560A/GS1561 presents data to the output data bus without performing any decoding, descrambling or word-alignment.

As described in [Data Through Mode on page 46](#), the data bus outputs will be forced to logic LOW if the device is set to operate in master mode but cannot identify SMPTE TRS ID words in the input data stream.

3.11.5 Parallel Output Clock (PCLK)

The frequency of the PCLK output signal of the GS1560A/GS1561 is determined by the output data format. [Table 3-16](#) below lists the possible output signal formats and their corresponding parallel clock rates. Note that DVB-ASI output will always be in 10-bit format, regardless of the setting of the 20bit/10bit pin.

Table 3-16: Parallel Data Output Format

Output Data Format	DOUT [19:10]	DOUT [9:0]	PCLK	Status / Control Signals*			
				20bit/10bit	SD/HD	SMPTE_BYPASS	DVB_ASI
SMPTE MODE							
20bit DEMULTIPLEXED SD	LUMA	CHROMA	13.5MHz	HIGH	HIGH	HIGH	LOW
10bit MULTIPLEXED SD	LUMA / CHROMA	FORCED LOW	27MHz	LOW	HIGH	HIGH	LOW
20bit DEMULTIPLEXED HD	LUMA	CHROMA	74.25 or 74.25/1.001MHz	HIGH	LOW	HIGH	LOW
10bit MULTIPLEXED HD	LUMA / CHROMA	FORCED LOW	148.5 or 148.5/1.001MHz	LOW	LOW	HIGH	LOW
DVB-ASI MODE							
10bit DVB-ASI	DVB-ASI DATA	FORCED LOW	27MHz	HIGH	HIGH	LOW	HIGH
	DVB-ASI DATA	FORCED LOW	27MHz	LOW	HIGH	LOW	HIGH
DATA-THROUGH MODE**							
20bit DEMULTIPLEXED SD	DATA	DATA	13.5MHz	HIGH	HIGH	LOW	LOW
10bit MULTIPLEXED SD	DATA	FORCED LOW	27MHz	LOW	HIGH	LOW	LOW
20bit DEMULTIPLEXED HD	DATA	DATA	74.25 or 74.25/1.001MHz	HIGH	LOW	LOW	LOW
10bit MULTIPLEXED HD	DATA	FORCED LOW	148.5 or 148.5/1.001MHz	LOW	LOW	LOW	LOW

*NOTE1: Recall that SD/HD, SMPTE_BYPASS, and DVB_ASI are input control pins in slave mode to be set by the application layer, but the SD/HD and SMPTE_BYPASS pins are output status signals set by the device in master mode.

**NOTE 2: Data-Through mode is only available in slave mode [Data Through Mode on page 46](#).

3.12 GSPI Host Interface

The GSPI, or Gennum Serial Peripheral Interface, is a 4-wire interface provided to allow the host to enable additional features of the device and /or to provide additional status information through configuration registers in the GS1560A/GS1561.

The GSPI comprises a serial data input signal SDIN, serial data output signal SDOUT, an active low chip select \overline{CS} , and a burst clock SCLK. The burst clock must have a duty cycle between 40% and 60%.

Because these pins are shared with the JTAG interface port, an additional control signal pin JTAG/ \overline{HOST} is provided. When JTAG/ \overline{HOST} is LOW, the GSPI interface is enabled.

When operating in GSPI mode, the SCLK, SDIN, and \overline{CS} signals are provided by the host interface. The SDOUT pin is a high-impedance output allowing multiple devices to be connected in parallel and selected via the \overline{CS} input. The interface is illustrated in Figure 3-9.

All read or write access to the GS1560A/GS1561 is initiated and terminated by the host processor. Each access always begins with a 16-bit command word on SDIN indicating the address of the register of interest. This is followed by a 16-bit data word on SDIN in write mode, or a 16-bit data word on SDOUT in read mode.

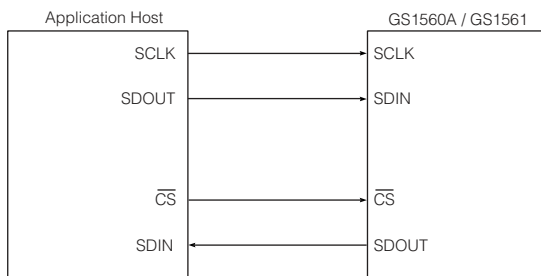

Figure 3-9: Gennum Serial Peripheral Interface (GSPI)

3.12.1 Command Word Description

The command word is transmitted MSB first and contains a read/write bit, nine reserved bits and a 6-bit register address. Set R/W = '1' to read and R/W = '0' to write from the GSPI.

Command words are clocked into the GS1560A/GS1561 on the rising edge of the serial clock SCLK. The appropriate chip select, \overline{CS} , signal must be asserted low a minimum of 1.5ns (t_0 in Figure 3-12 and Figure 3-13) before the first clock edge to ensure proper operation.

Each command word must be followed by only one data word to ensure proper operation.



Figure 3-10: Command Word

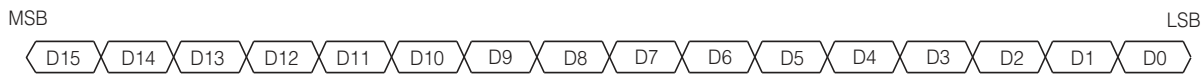

Figure 3-11: Data Word

3.12.2 Data Read and Write Timing

Read and write mode timing for the GSPI interface is shown in Figure 3-12 and Figure 3-13 respectively. The maximum SCLK frequency allowed is 6.6MHz.

When writing to the registers via the GSPI, the MSB of the data word may be presented to SDIN immediately following the falling edge of the LSB of the command word. All SDIN data is sampled on the rising edge of SCLK.

When reading from the registers via the GSPI, the MSB of the data word will be available on SDOUT 12ns following the falling edge of the LSB of the command word, and thus may be read by the host on the very next rising edge of the clock. The remaining bits are clocked out by the GS1560A on the negative edges of SCLK.

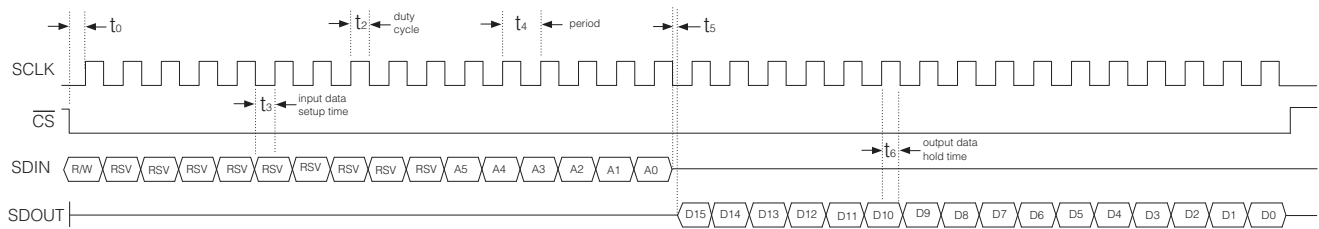

Figure 3-12: GSPI Read Mode Timing

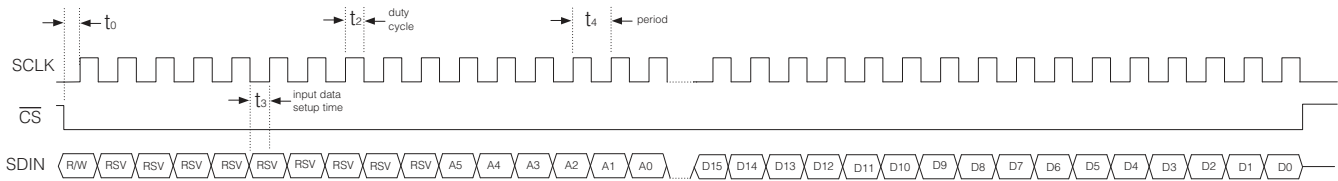

Figure 3-13: GSPI Write Mode Timing

3.12.3 Configuration and Status Registers

Table 3-17 summarizes the GS1560A/GS1561's internal status and configuration registers.

All of these registers are available to the host via the GSPI and are all individually addressable.

Where status registers contain less than the full 16 bits of information however, two or more registers may be combined at a single logical address.

Table 3-17: GS1560A internal registers

Address	Register Name	See Section
000h	IOPROC_DISABLE	Section 3.10.6
001h	ERROR_STATUS	Section 3.10.5
003h	EDH_FLAG	Section 3.10.7
004h	VIDEO_STANDARD	Section 3.10.4
005h - 009h	ANC_TYPE	Section 3.10.2.1
00Ch - 00Dh	VIDEO_FORMAT	Section 3.10.3
00Eh - 011h	RASTER_STRUCTURE	Section 3.10.4
012h - 019h	EDH_CALC_RANGES	Section 3.10.5.2
01Ah	ERROR_MASK	Section 3.10.5

3.13 JTAG

When the JTAG/ $\overline{\text{HOST}}$ input pin of the GS1560A/GS1561 is set HIGH, the host interface port will be configured for JTAG test operation. In this mode, pins 27 through 30 become TMS, TDO, TDI, and TCK. In addition, the $\overline{\text{RESET_TRST}}$ pin will operate as the test reset pin.

Boundary scan testing using the JTAG interface will be enabled in this mode.

There are two methods in which JTAG can be used on the GS1560A/GS1561:

1. As a stand-alone JTAG interface to be used at in-circuit ATE (Automatic Test Equipment) during PCB assembly; or
2. Under control of the host for applications such as system power on self tests.

When the JTAG tests are applied by ATE, care must be taken to disable any other devices driving the digital I/O pins. If the tests are to be applied only at ATE, this can be accomplished with tri-state buffers used in conjunction with the JTAG/ $\overline{\text{HOST}}$ input signal. This is shown in Figure 3-14.

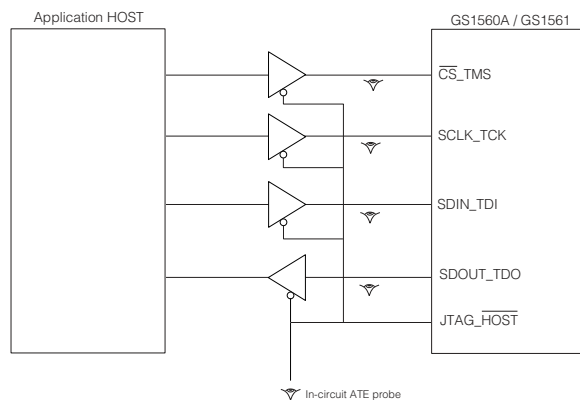

Figure 3-14: In-Circuit JTAG

Alternatively, if the test capabilities are to be used in the system, the host may still control the JTAG/ $\overline{\text{HOST}}$ input signal, but some means for tri-stating the host must exist in order to use the interface at ATE. This is represented in Figure 3-15.

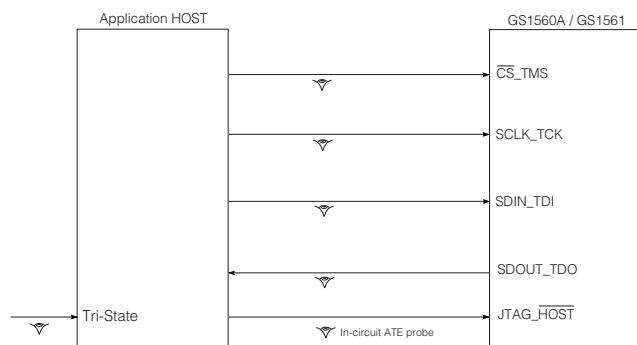

Figure 3-15: System JTAG

Please contact your Gennum representative to obtain the BSDL model for the GS1560A/GS1561.

3.14 Device Power Up

The GS1560A/GS1561 has a recommended power supply sequence. To ensure correct power up, power the CORE_VDD pins before the IO_VDD pins.

Device pins may also be driven prior to power up without causing damage.

To ensure that all internal registers are cleared upon power-up, the application layer must hold the $\overline{\text{RESET_TRST}}$ signal LOW for a minimum of 1ms after the core power supply has reached the minimum level specified in Table 2-1. See Figure 3-16.

3.15 Device Reset

In order to initialize all internal operating conditions to their default states the application layer must hold the $\overline{\text{RESET_TRST}}$ signal LOW for a minimum of $t_{\text{reset}} = 1\text{ms}$.

When held in reset, all device outputs will be driven to a high-impedance state.

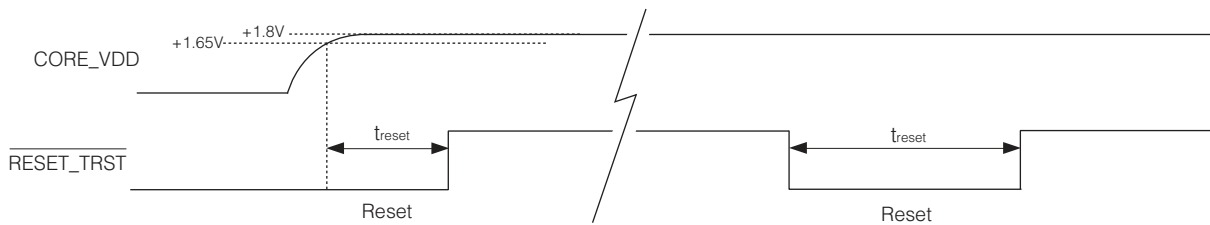
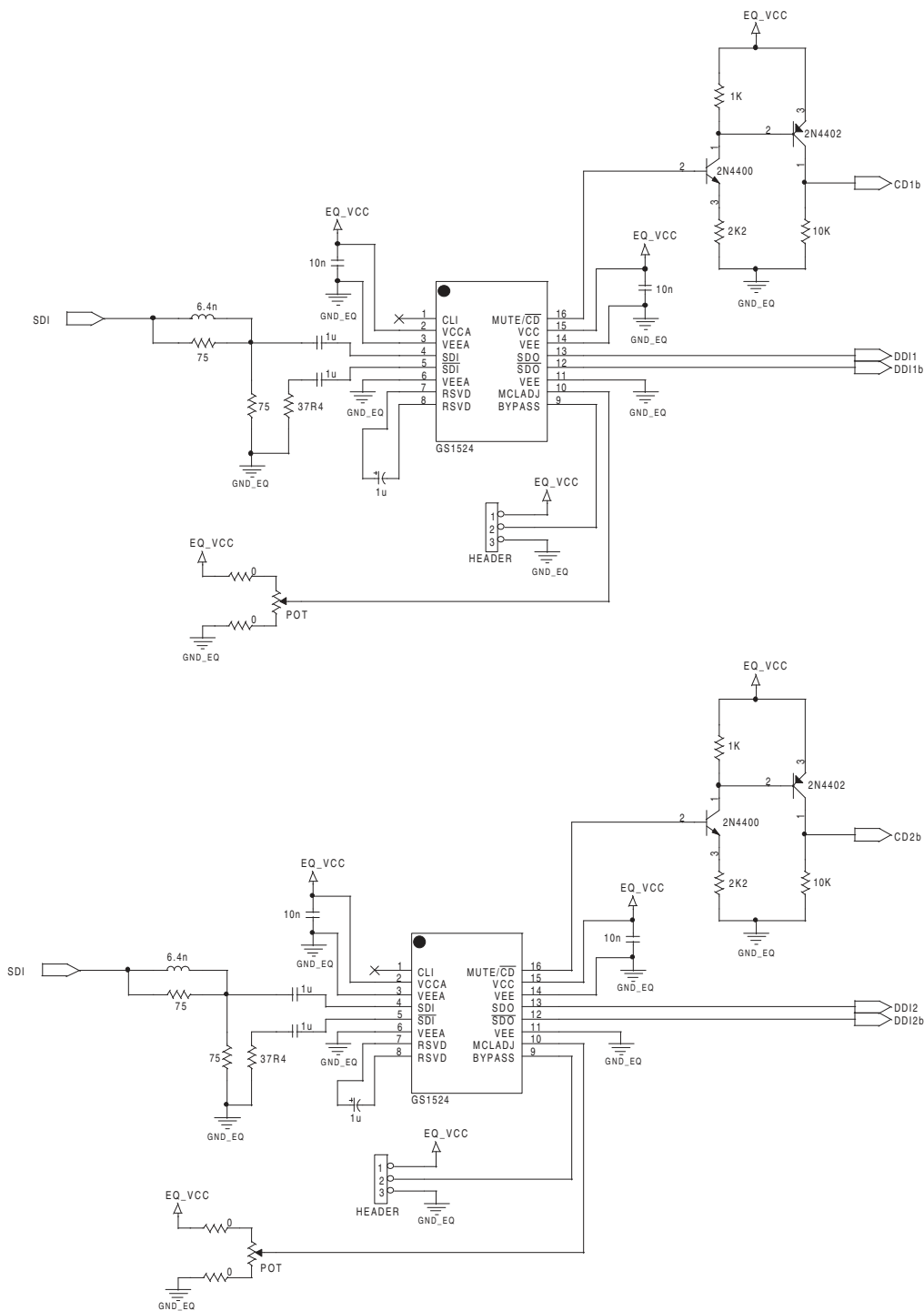

Figure 3-16: Reset Pulse

4. Application Reference Design

4.1 GS1560A Typical Application Circuit (Part A)



4.2 GS1560A Typical Application Circuit (Part B)

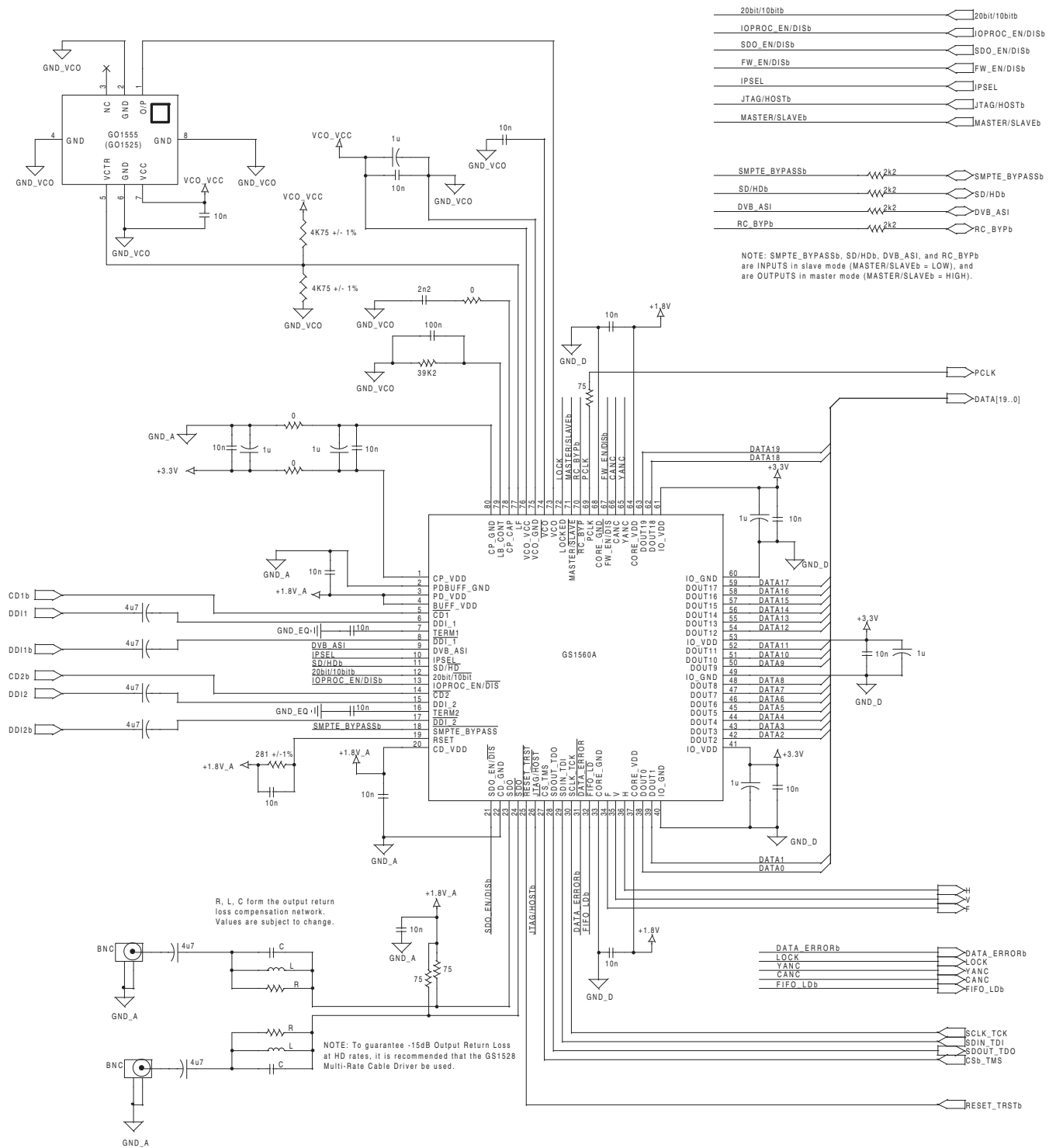

4.3 GS1561 Typical Application Circuit (Part A)

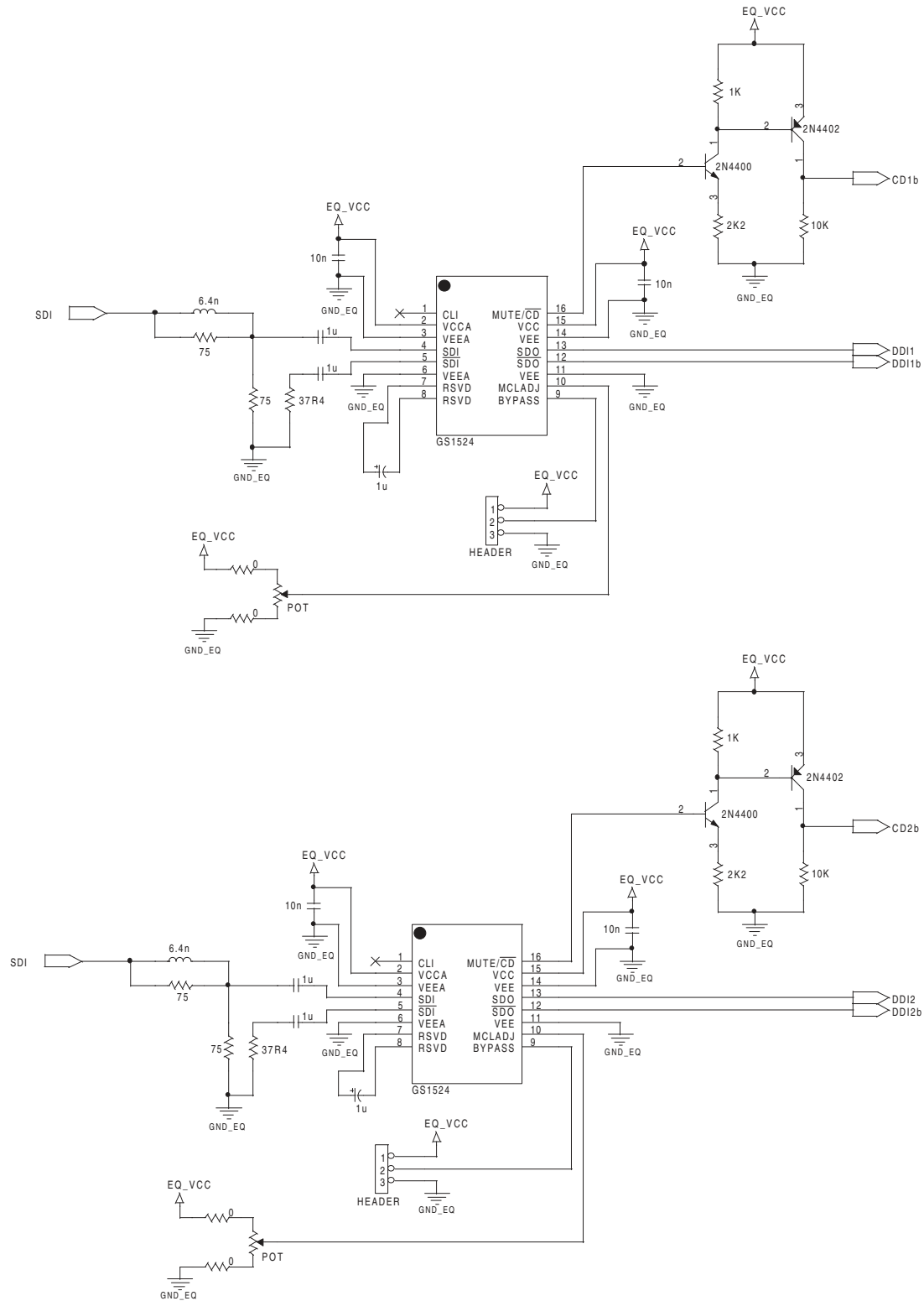

4.4 GS1561 Typical Application Circuit (Part B)

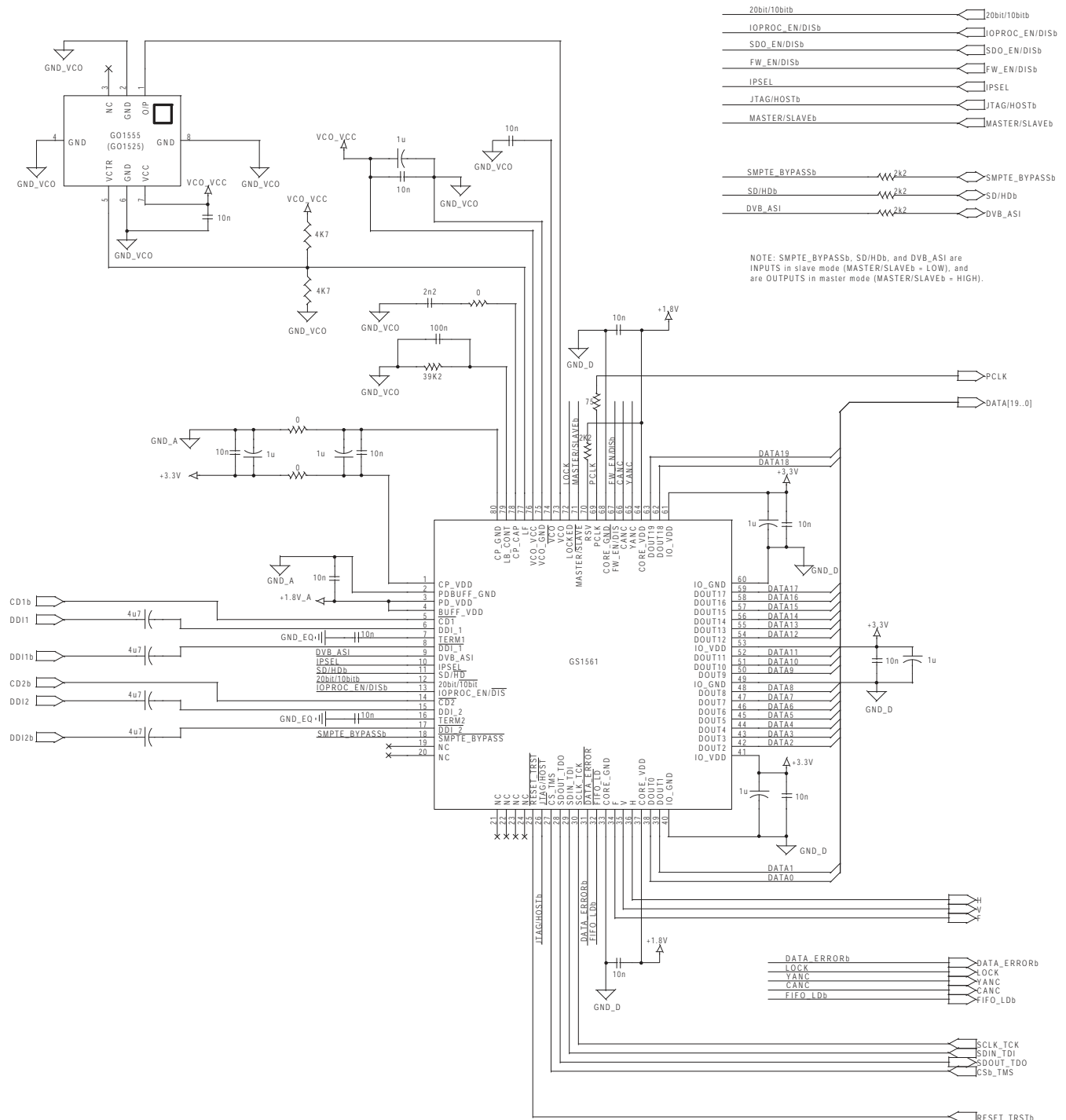

5. References & Relevant Standards

SMPTE 125M	Component video signal 4:2:2 – bit parallel interface
SMPTE 260M	1125 / 60 high definition production system – digital representation and bit parallel interface
SMPTE 267M	Bit parallel digital interface – component video signal 4:2:2 16 x 9 aspect ratio
SMPTE 274M	1920 x 1080 scanning analog and parallel digital interfaces for multiple picture rates
SMPTE 291M	Ancillary Data Packet and Space Formatting
SMPTE 292M	Bit-Serial Digital Interface for High-Definition Television Systems
SMPTE 293M	720 x 483 active line at 59.94 Hz progressive scan production – digital representation
SMPTE 296M	1280 x 720 scanning, analog and digital representation and analog interface
SMPTE 352M	Video Payload Identification for Digital Television Interfaces
SMPTE RP165	Error Detection Checkwords and Status Flags for Use in Bit-Serial Digital Interfaces for Television
SMPTE RP168	Definition of Vertical Interval Switching Point for Synchronous Video Switching

6. Package & Ordering Information

6.1 Package Dimensions

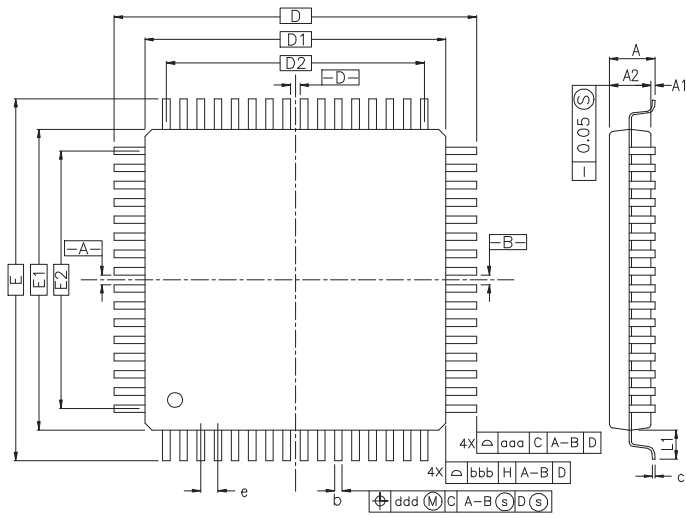

Table X

SYMBOL	MILLIMETER			INCH		
	MIN.	NOM.	MAX.	MIN.	NOM.	MAX.
A	—	—	1.60	—	—	0.063
A1	0.05	—	0.15	0.002	—	0.006
A2	1.35	1.40	1.45	0.053	0.055	0.057
D	16.00 BSC.			0.630 BSC.		
D1	14.00 BSC.			0.551 BSC.		
E	16.00 BSC.			0.630 BSC.		
E1	14.00 BSC.			0.551 BSC.		
R2	0.08	—	0.20	0.003	—	0.008
R1	0.08	—	—	0.003	—	—
θ	0°	3.5°	7°	0°	3.5°	7°
θ_1	0°	—	—	0°	—	—
θ_2	11°	12°	13°	11°	12°	13°
θ_3	11°	12°	13°	11°	12°	13°
c	0.09	—	0.20	0.004	—	0.008
L	0.45	0.60	0.75	0.018	0.024	0.030
L1	1.00 REF			0.039 REF		
S	0.20	—	—	0.008	—	—

CONTROL DIMENSIONS ARE IN MILLIMETERS.

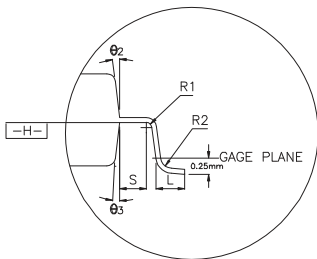
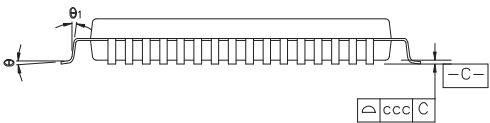

Table Y

SYMBOL	80L					
	MILLIMETER			INCH		
	MIN	NOM	MAX	MIN	NOM	MAX
b	0.22	0.30	0.38	0.009	0.012	0.015
e	0.65 BSC			0.026 BSC		
D2	12.35			0.486		
E2	12.35			0.486		
TOLERANCES OF FORM AND POSITION						
aaa	0.20			0.008		
bbb	0.20			0.008		
ccc	0.10			0.004		
ddd	0.13			0.005		

NOTES:

Diagram shown is representative only. Table X is fixed for all pin sizes, and Table Y is specific to the 80-pin package.

- DIMENSIONS D1 AND E1 DO NOT INCLUDE MOLD PROTRUSION. ALLOWABLE PROTRUSION IS 0.25mm PER SIDE. D1 AND E1 ARE MAXIMUM PLASTIC BODY SIZE DIMENSIONS INCLUDING MOLD MISMATCH.
- DIMENSION b DOES NOT INCLUDE DAMBAR PROTRUSION. ALLOWABLE DAMBAR PROTRUSION SHALL NOT CAUSE THE LEAD WIDTH TO EXCEED THE MAXIMUM b DIMENSION BY MORE THAN 0.08mm. DAMBAR CAN NOT BE LOCATED ON THE LOWER RADIUS OR THE FOOT. MINIMUM SPACE BETWEEN PROTRUSION AND AN ADJACENT LEAD IS 0.07mm FOR 0.4mm AND 0.5mm PITCH PACKAGES.

6.2 Packaging Data

Parameter	Value
Package Type	14mm x 14mm 80-pin LQFP
Package Drawing Reference	JEDEC MS026
Moisture Sensitivity Level	3
Junction to Case Thermal Resistance, θ_{j-c}	11.6°C/W
Junction to Air Thermal Resistance, θ_{j-a} (at zero airflow)	39.9°C/W
Psi	0.6°C/W
Pb-free and RoHS Compliant	Yes

6.3 Ordering Information

Part Number	Pb-free and RoHS Compliant	Loop-Through	Package	Temperature Range
GS1560ACF	No	Yes	80-pin LQFP	0°C to 70°C
GS1560ACFE3	Yes	Yes	80-pin LQFP	0°C to 70°C
GS1561-CF	No	No	80-pin LQFP	0°C to 70°C
GS1561-CFE3	Yes	No	80-pin LQFP	0°C to 70°C

**DOCUMENT IDENTIFICATION
DATA SHEET**

The product is in production. Gennum reserves the right to make changes to the product at any time without notice to improve reliability, function or design, in order to provide the best product possible.

CAUTION

ELECTROSTATIC SENSITIVE DEVICES

DO NOT OPEN PACKAGES OR HANDLE EXCEPT AT A
STATIC-FREE WORKSTATION

GENNUM CORPORATION

Mailing Address: P.O. Box 489, Station A, Burlington, Ontario L7R 3Y3 Canada
Street Addresses: 4281 Harvester Road, Burlington, Ontario L7L 5M4 Canada
Phone: +1 (905) 632-2996 Fax: +1 (905) 632-2055
Email: corporate@gennum.com www.gennum.com

OTTAWA DESIGN CENTRE

232 Herzberg Road, Suite 101
Kanata, Ontario K2K 2A1
Canada

Phone: +1 (613) 270-0458
Fax: +1 (613) 270-0429

UNITED KINGDOM DESIGN CENTRE

North Building, Walden Court
Parsonage Lane,
Bishop's Stortford Hertfordshire, CM23 6DB
Great Britain

Phone: +44 (1279) 714170
Fax: +44 (1279) 714171

JAPAN KK

Shinjuku Green Tower Building 27F
6-14-1, Nishi Shinjuku
Shinjuku-ku, Tokyo, 160-0023
Japan

Phone: +81 (03) 3349 5501
Fax: +81 (03) 3349 5505
Email: gennum-japan@gennum.com
Web Site: <http://www.gennum.co.jp>

SNOWBUSH IP - A DIVISION OF GENNUM

439 University Ave. Suite 1700
Toronto, Ontario M5G 1Y8
Canada

Phone: +1 (416) 925-5643
Fax: +1 (416) 925-0581

Web Site: <http://www.snowbush.com>

**AGUASCALIENTES PHYSICAL DESIGN
CENTER**

Venustiano Carranza 122 Int. 1
Centro, Aguascalientes
Mexico CP 20000

Phone: +1 (416) 848-0328

GERMANY

Niederlassung Deutschland
Stefan-George-Ring 29
81929 München, Germany

Phone: +49 89 309040 290
Fax: +49 89 309040 293

Email: gennum-germany@gennum.com

UNITED STATES - WESTERN REGION

Bayshore Plaza
2107 N 1st Street, Suite #300
San Jose, CA 95131
United States

Phone: +1 (408) 392-9430
Fax: +1 (408) 392-9404

UNITED STATES - EASTERN REGION

4281 Harvester Road
Burlington, Ontario L7L 5M4
Canada

Phone: +1 (905) 632-2996
Fax: +1 (905) 632-2055

TAIWAN

6F-4, No.51, Sec.2, Keelung Rd.
Sinyi District, Taipei City 11502
Taiwan R.O.C.

Phone: (886) 2-8732-8879
Fax: (886) 2-8732-8870

KOREA

8F, Jinnex Lakeview Bldg.
65-2, Bangidong, Songpagu
Seoul, Korea 138-828

Phone: +82-2-414-2991
Fax: +82-2-414-2998

Gennum Corporation assumes no liability for any errors or omissions in this document, or for the use of the circuits or devices described herein. The sale of the circuit or device described herein does not imply any patent license, and Gennum makes no representation that the circuit or device is free from patent infringement.

All other trademarks mentioned are the properties of their respective owners.

GENNUM and the Gennum logo are registered trademarks of Gennum Corporation.

© Copyright 2003 Gennum Corporation. All rights reserved. Printed in Canada.

www.gennum.com