

REVISIONS

REV.	DESCRIPTION	DATE	APPROVED
A	ECO #7560	04/24/09	M.J.

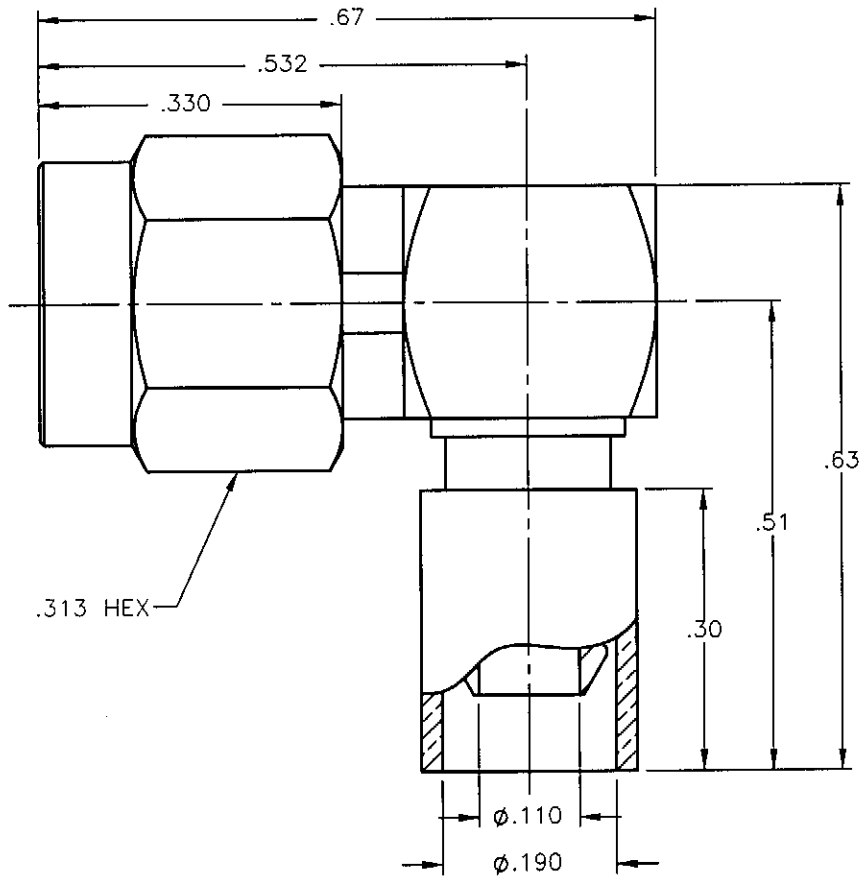
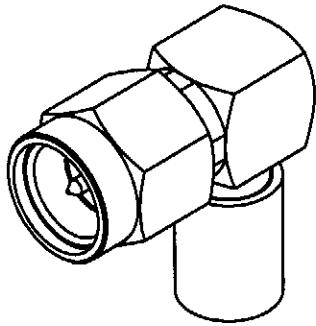

NOTES:

MATERIALS:

1. BODY & COUPLING NUT = STAINLESS STEEL PER ASTM A582, ALLOY 303, CONDITION "A".
2. INSULATORS = VIRGIN WHITE TEFLON PER ASTM D1710, GRADE 1, TYPE I, CLASS "B".
3. CONTACT & RETAINING RING = BERYLLIUM COPPER PER ASTM B196, ALLOY C17300, TEMPER TD04.
4. CAP = BRASS PER ASTM B16, ALLOY C36000, TEMPER H02.
5. GASKET = SILICONE RUBBER PER ZZ-R-765, CLASS 2B, GRADE 65-75.
6. CRIMP SLEEVE = SEAMLESS LOWLEAD BRASS TUBE, ALLOY 330, SOFT ANNEAL TEMPER, .025/.060 GRAIN SIZE OR SEAMLESS COPPER TUBE PER ASTM B75, TYPE C12000, TEMPER: LIGHT ANNEAL 050 EXCEPT YIELD STRENGTH.
7. SHRINK SLEEVE = BLACK THERMOFIT SCL (NOT SHOWN).

FINISHES:

1. BODY & COUPLING NUT = PASSIVATE PER QQ-P-35, TYPE VI.
2. CONTACT = GOLD PLATE PER MIL-G-45204, TYPE II, CLASS 1, GRADE C, OVER .00010 TO .00020 STRESS FREE SULFAMATE NICKEL PER QQ-N-290.
3. CRIMP SLEEVE & CAP = NICKEL PLATE PER QQ-N-290, CLASS 1, GRADE G, EXCEPT .0001 TO .0002 THICK OVER .00005 TO .0001 THICK COPPER PER MIL-C-14550.

Property of Radiall Incorporated  
This document cannot be reproduced or communicated to a third party without prior written permission of RADIALL Incorporated.

UNLESS OTHERWISE SPECIFIED DIMENSIONS ARE IN INCHES TOLERANCES ON	DWN:	DATE
	M.J.	04/24/09
	CHKD:	DATE
	D.N.	04/24/09
DECIMAL	ANGLE	APVD:
		J.M.
		DATE
		04/24/09



APPLIED ENGINEERING PRODUCTS

104 John W. Murphy Dr.  
New Haven, CT 06513

a RADIALL company

SMA RIGHT ANGLE PLUG  
CRIMP TYPE  
FOR RG-180 & SIMILAR CABLES

REFERENCE:	MATERIALS & FINISHES:
ORIGINATED: D.N. DATE: 11/18/94	SEE NOTES

SIZE	FSCM NO.	DWG NO.	REV
A	19505	9043-9523-004	A
SCALE 5:1		THIRD ANGLE PROJECTION	SHEET 1 OF 1

9043-9523-004