

PRODUCT DATA DRAWING

REVISION HISTORY			
REV	DESCRIPTION	DATE	APPROVED
-	REL. NRN 33880	11/20/06	STW

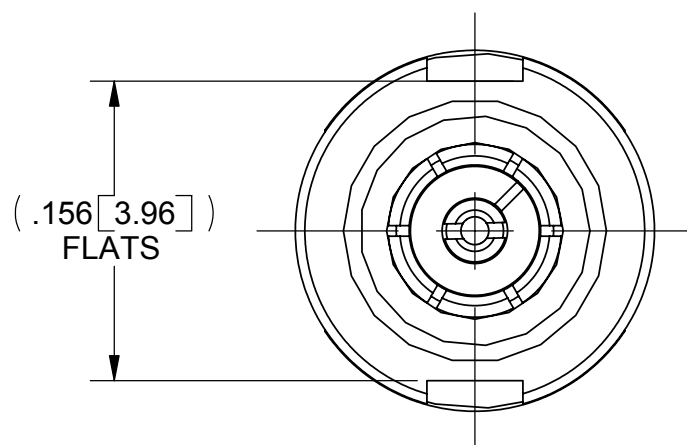

SMPM INTERFACE
PER MIL-STD-348
ACCEPTS
Ø .012 [0.30] PIN

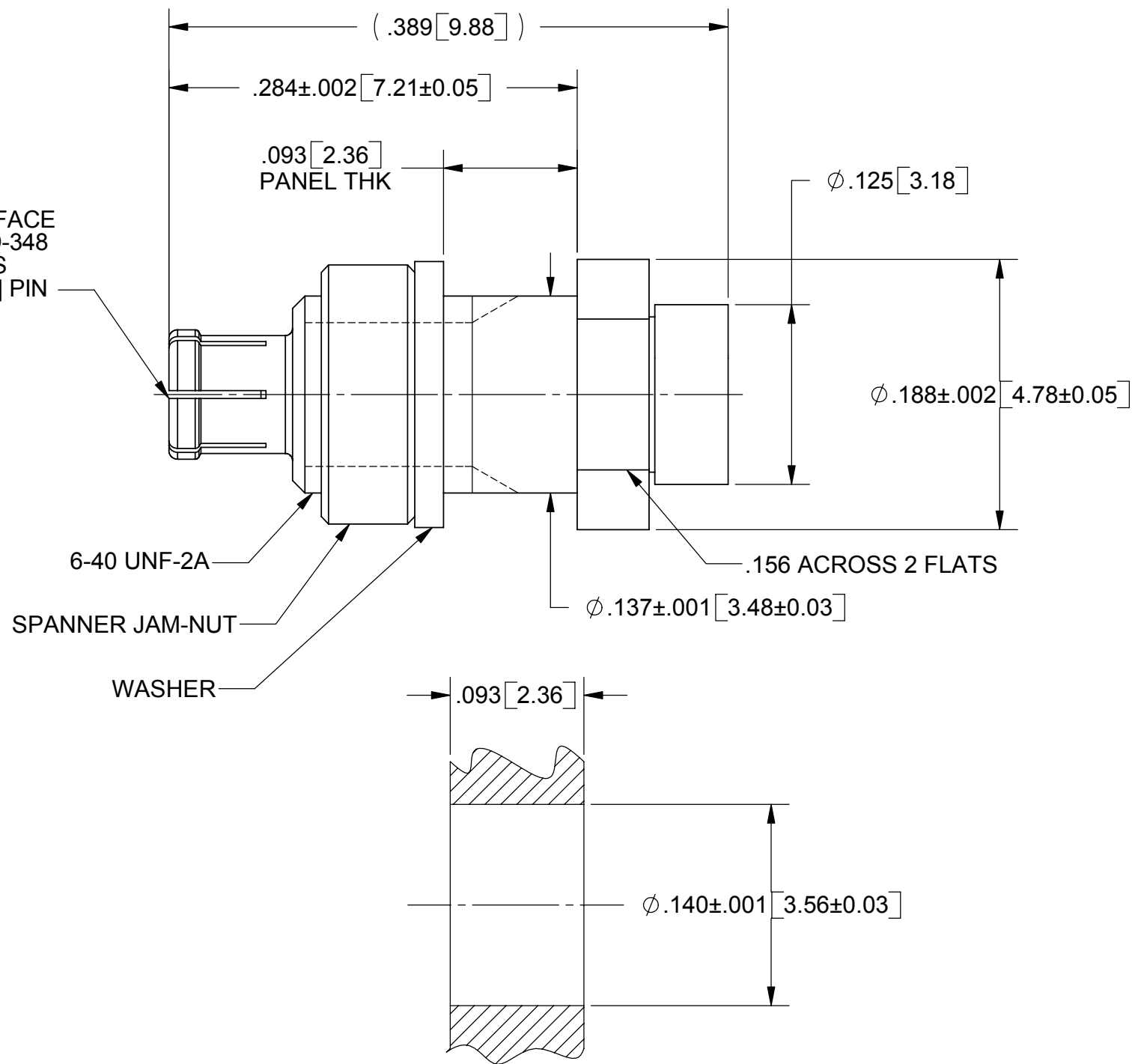

RECOMMENDED MOUNTING HOLE

- MATERIAL:**
- BODY & CONTACT:** BERYLLIUM COPPER PER ASTM B196, ALLOY No. UNS C17300, TD04.
 - INSERT, WASHER & JAM NUT:** BRASS PER ASTM B16, ALLOY No. UNS C36000.
 - LOCK WASHER:** PHOSPHOR BRONZE PER ASTM B103
 - INSULATOR:** PTFE PER ASTM D1710, TYPE I, GRADE 1, CLASS B
- FINISH:**
- BODY, INSERT & CONTACT:** GOLD PER ASTM B488, TYPE II, CODE C, CLASS 1.27; OVER NICKEL PER AMS-QQ-N-290, CLASS 1, .00005" MIN.
 - JAM NUT & LOCKWASHER:** NICKEL PLATE PER AMS-QQ-N-290, CLASS 2, .000050 MIN THICK

- PERFORMANCE:**
- IMPEDANCE:** 50 OHMS
 - FREQ. RANGE:** DC TO 65.0 GHz
 - DWV:** 325 VRMS
 - OPERATING TEMP.:** -55 °C TO +125 °C

MATERIAL: SEE NOTES	DIMENSIONS ARE IN INCHES TOLERANCES: FRACTIONAL: ±1/64 ANGULAR: X° ±1'0" X'X' ±15'	UNLESS OTHERWISE SPECIFIED 1) ALL DIMENSIONS ARE IN INCHES (MILLIMETERS) 2) ALL DIMENSIONS ARE AFTER PLATING. 3) BREAK CORNERS & EDGES .005 R. MAX. 4) CHAM. 1ST & LAST THREADS. 5) SURFACE ROUGHNESS 63-MIL-STD-10. 6) DIA.'S ON COMMON CENTERS TO BE CONCENTRIC WITHIN .005 T.I.R. 7) REMOVE ALL BURRS	SV Microwave, Inc. 2400 Centrepark West Drive, Suite 100 West Palm Beach, FL 33409 TITLE: SMPM FEMALE BULKHEAD MT. FOR T-FLEX 405 CABLE	
FINISH: SEE NOTES	DECIMAL: X ±.030 .XX ±.010 .XXX ±.005			
SURFACE AREA: N/A	INTERPRET DIMENSIONS AND TOLERANCES PER ASME Y14.5M - 1994		DRAWN: JMC 11/02/06	
PROPRIETARY	THIRD ANGLE PROJECTION		CHECKED: JM 11/02/06	SIZE B CAGE CODE 95077 DWG. NO. 3221-4000
THE INFORMATION CONTAINED IN THIS DRAWING IS THE SOLE PROPERTY OF SV MICROWAVE, INC. ANY REPRODUCTION IN PART OR AS A WHOLE WITHOUT THE WRITTEN PERMISSION OF SV MICROWAVE, INC IS PROHIBITED.			APPROVED: JM 11/02/06	SCALE: 10:1 SHEET 1 OF 1