

Customer Information Sheet

DRAWING No.: S0911-46R

IF IN DOUBT - ASK

©

NOT TO SCALE

THIRD ANGLE PROJECTION

ALL DIMENSIONS IN mm

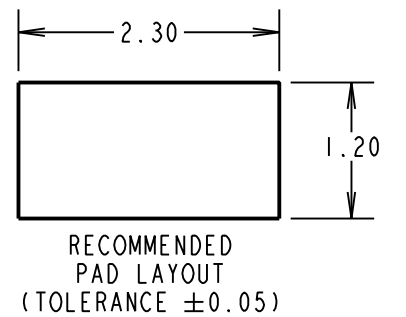
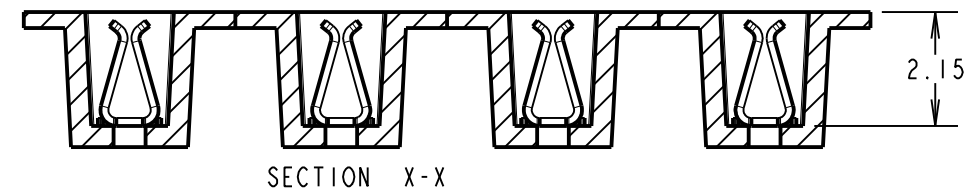
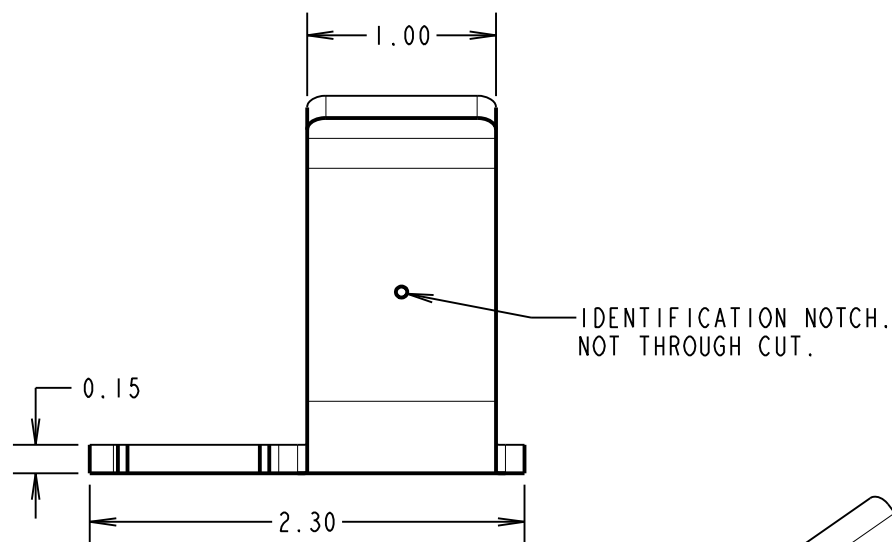
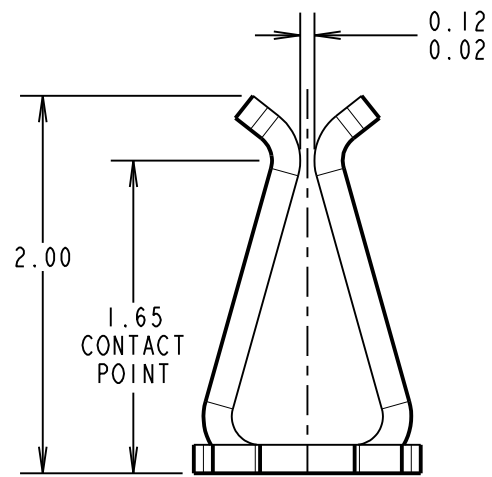
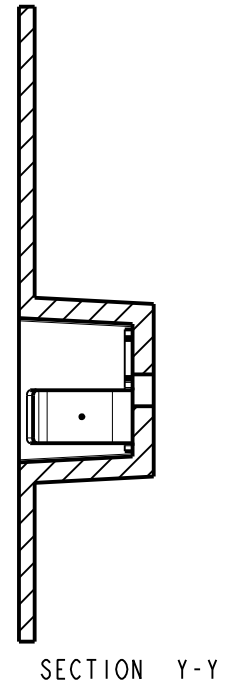
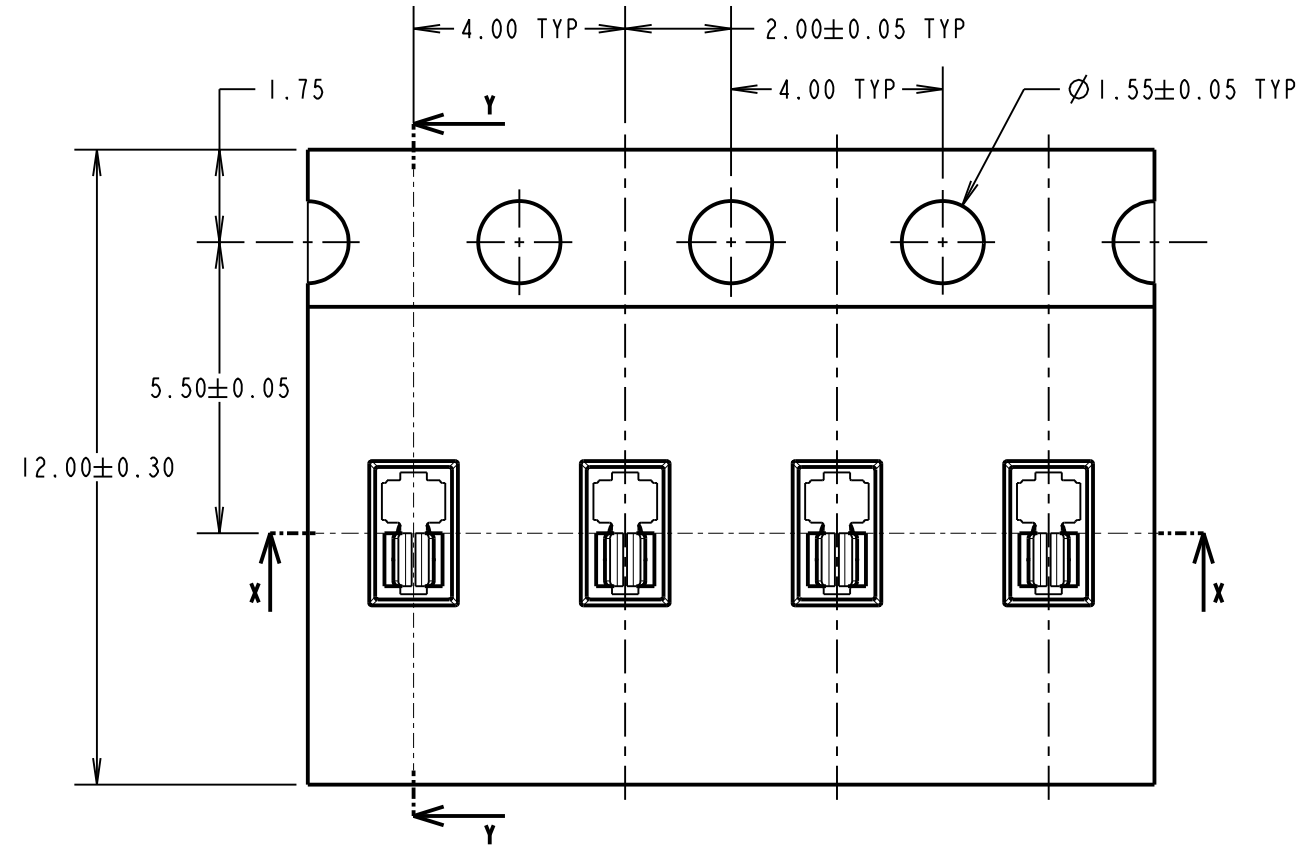
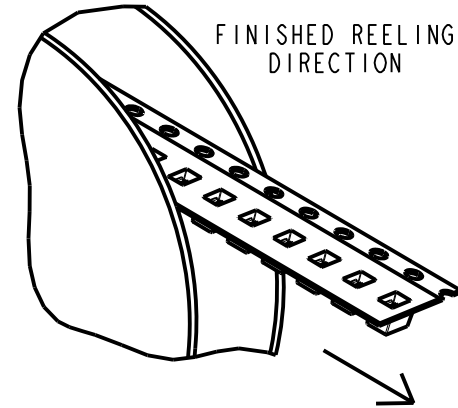
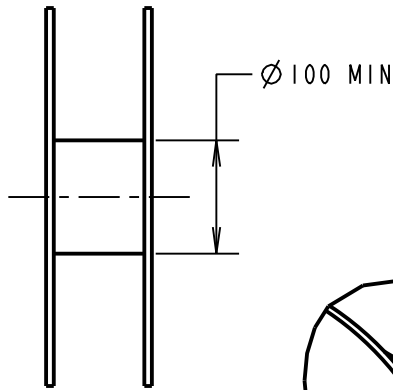
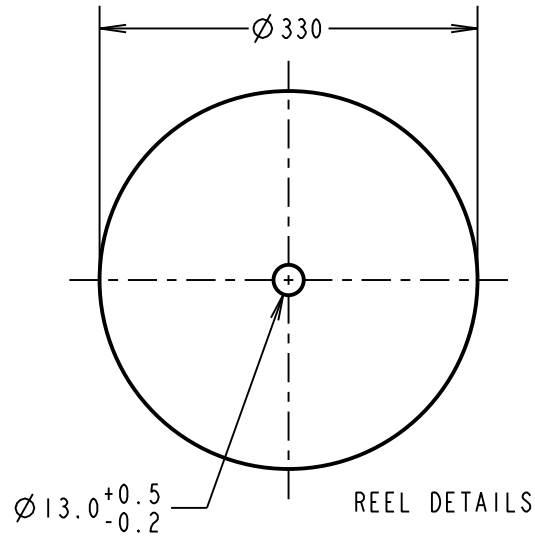

CROPPED COMPONENT DIMENSIONS

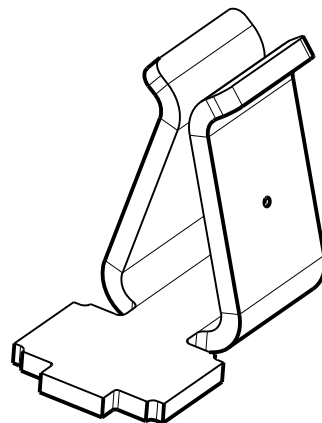
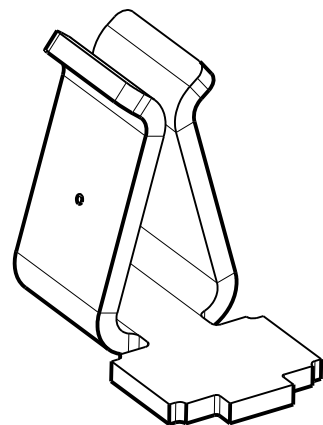
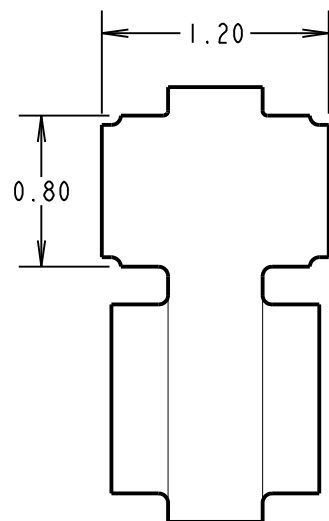

COMPONENT SPECIFICATION:
 MATERIAL = BERYLLIUM COPPER
 FINISH = 2.40µm - 3.60µm TIN OVER
 2.00µm - 2.80µm NICKEL

ELECTRICAL:
 CONTACT RESISTANCE = 25mΩ MAX

MECHANICAL:
 MAX INSERTION FORCE WITH 0.20mm SHEET = 3.00N
 MIN INSERTION FORCE WITH 0.20mm SHEET = 0.10N
 MAX WITHDRAWAL FORCE WITH 0.20mm SHEET = 2.50N
 MIN WITHDRAWAL FORCE WITH 0.20mm SHEET = 0.10N
 DURABILITY = 20 CYCLES

ENVIRONMENTAL:
 OPERATING TEMPERATURE = -55°C TO +105°C

- NOTES:
- QUANTITY OF COMPONENTS PER REEL: 6,500.
 - THIS PRODUCT IS TAPE AND REELED IN GENERAL ACCORDANCE WITH EIA-481-2 (ELECTRONICS INDUSTRIES ASSOCIATION).
 - RECOMMENDED CAN THICKNESS: 0.15-20mm.

| | | | |
|----------------|------|------------|--------|
| MR | 1 | 11.03.19 | 21823 |
| NAME | ISS. | DATE | C/NOTE |
| APPROVED: | | M. RUDKIN | |
| CHECKED: | | S. BENNETT | |
| DRAWN: | | S. BENNETT | |
| CUSTOMER REF.: | | | |
| ASSEMBLY DRG: | | | |

HARWIN

www.harwin.com
 technical@harwin.com

THIS DRAWING AND ANY INFORMATION OR DESCRIPTIVE MATTER SET OUT HEREON ARE CONFIDENTIAL AND COPYRIGHT PROPERTY OF THE HARWIN GROUP AND MUST NOT BE DISCLOSED, LOANED, COPIED OR USED FOR MANUFACTURING, TENDERING OR FOR ANY OTHER PURPOSE WITHOUT THEIR WRITTEN PERMISSION.

TOLERANCES
 X. = ±1mm
 X.X = ±0.50mm
 X.XX = ±0.20mm
 X.XXX = ±0.01mm
 ANGLES = ±5°
 UNLESS STATED

MATERIAL:
 SEE ABOVE
 FINISH: SEE ABOVE
 S/AREA: mm²

TITLE:
 COMPACT RFI SHIELD CLIP
 IN TAPE AND REEL

DRAWING NUMBER:
S0911-46R

SHT
 2 OF 2