

HF
Halogen Free

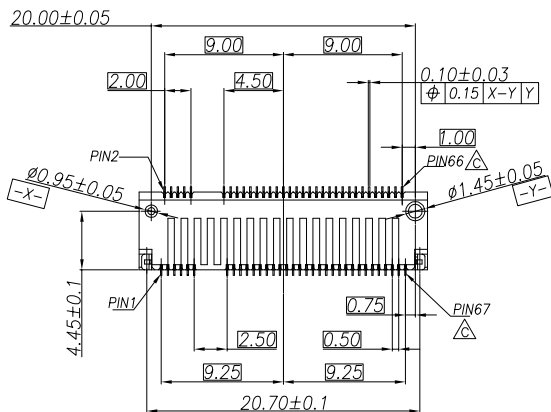

DATE CODE
SEE NOTES 4

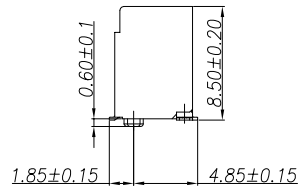
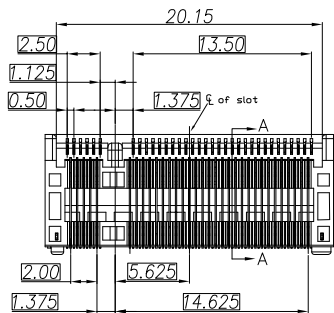
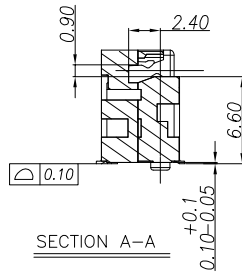
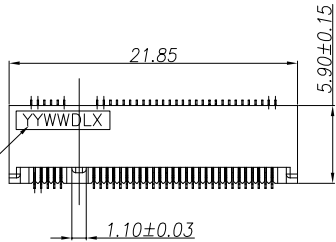

NOTES:

- 1.MATERIAL:
 - 1.1.HOUSING: LCP HIGH TEMPERATURE THERMOPLASTIC,UL94V-0,COLOR:BLACK
 - 1.2.CONTACTS: COPPER ALLOY;
 - 1.3.PEG: STAINLESS STEEL.
- 2.REFLOW SOLDER CAPABLE TO 260°C.
- 3.FINISH:

CONTACT:
50u" MIN NICKEL UNDERPLATING OVERALL.
CONTACT AREA: GOLD PLATED (SEE TABLE)
SOLDER AREA: GOLD FLASH 1u" MIN.

PEG:
50u" MIN. NICKEL UNDERPLATING OVERALL.
80u" MIN. MATTE-TIN PLATED ON SURFACE.

4. DATE CODE : YYWWDLX

YY: YEAR (09: 2009)
WW: WEEK (25: THE 25TH WEEK)
D: DAY (1~7: SUNDAY~SATURDAY)
L: LINE NUMBER OF ASSEMBLY (A: LINE A)
X: D OR N (D: DAY; N: NIGHT)

5.PRODUCT SPECIFICATION SEE FCI GS-12-1195

6.PART NO: 10128796-0 0 X R LF

LEAD FREE & RoHS COMPLIANCE
PACKING OPTION
R:TAPE&REEL
GOLD PLATING
1:GOLD FLASH
4:Au 15u"
5:Au 30u"

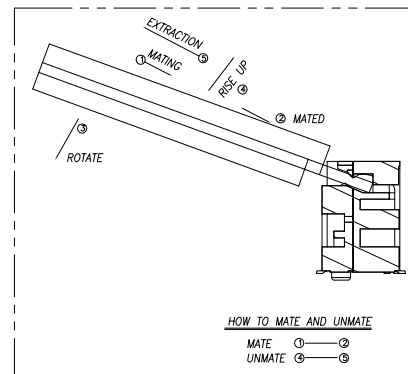

30u" Au	10128796-005RLF
15u" Au	10128796-004RLF
GOLD FLASH	10128796-001RLF
CONTACT AREA	FCI P/N

mat'l. code	-	surface	-	tolerance	ASME_Y14.5	projection	product family	-
ltr	ecn no	dr	date	tolerances unless otherwise specified		MM	title	
A		BF	2013-04-18	angles	.0±.0.30	Amphenol FCI	M.2_CONNECTOR	
B		ELX-T-19318	TAI	2014-11-10	.00±.0.25		8.5H_STD_KEY_B	
C		ELX-DG-24598	ZH	2016-07-13	.000±.0.10		sheet 1 of 3	
				dr	BEER_FU	2013-05-02	size	
				engr	BEER_FU	2013-05-02	A4	
				chr	BEER_FU	2013-05-02	10128796	
				appd	PM_ZHENG	2013-05-02	CUSTOMER Drawing	
sheet	revision	c						
index	sheet	3						



PLUG PCB

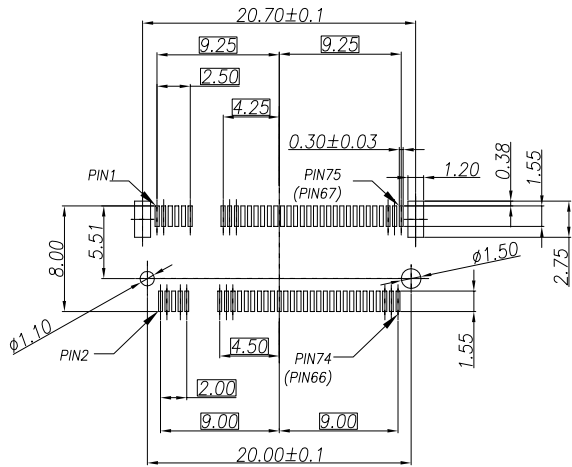
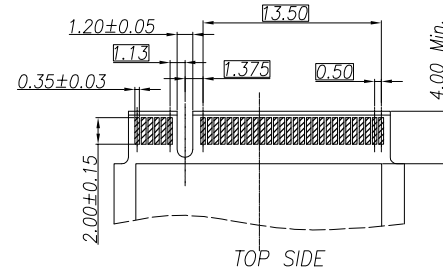
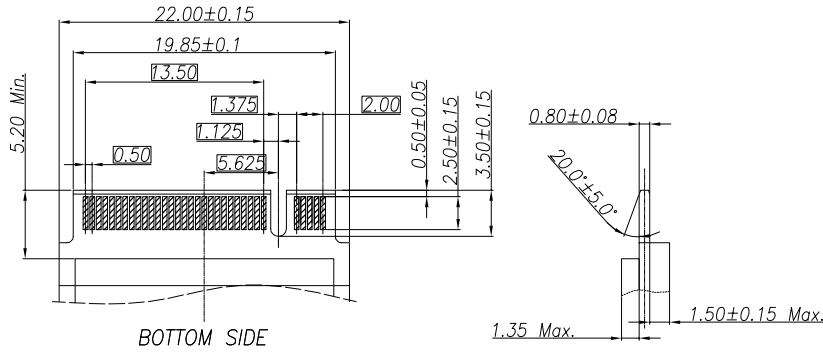

RECOMMENDED PCB LAYOUT
GENERAL TOLERANCE : ±0.05mm

mat'l. code	-	surface	-	tolerance	ASME_Y14.5	projection	ASME	product family	-
ltr	ecn no	dr	date	tolerances unless otherwise specified		MM	MM	title	M.2_CONNECTOR 8.5H_STD_KEY_B
				angles	lineal .0±.030 .00±.025 ±2' .000±.010	scale	N/A	dwg no	10128796
				dr	BEER_FU	2013-05-02	Amphenol FCI	sheet	2 of 3
				engr	BEER_FU	2013-05-02		size	A4
				chr	BEER_FU	2013-05-02			
				appd	PM_ZHENG	2013-05-02		type	CUSTOMER Drawing
sheet index	revision sheet	c	3						

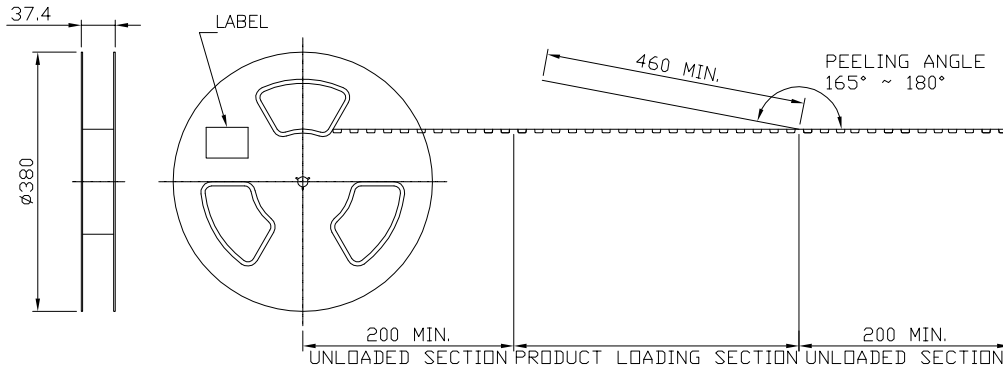

NOTES :

- MATERIAL :
COVER TAPE : ANTISTATIC P.S T=0.05±0.01 ,COLOR:CLEAR
CARRIER TAPE : ANTISTATIC P.S T=0.40±0.10,COLOR:BLACK
REEL : PS UL94V-0
CARTON: CORRUGATED FIBER
- DIMENSION :
REEL : SEE DRAWING
SHIPPING BOX: 385X385X225mm
- QUANTITY : SEE TABLE
- PEELING RESISTANCE : 10gf~130gf (for 12~56mm)
- PEELING SPEED : 300mm/MINUTES

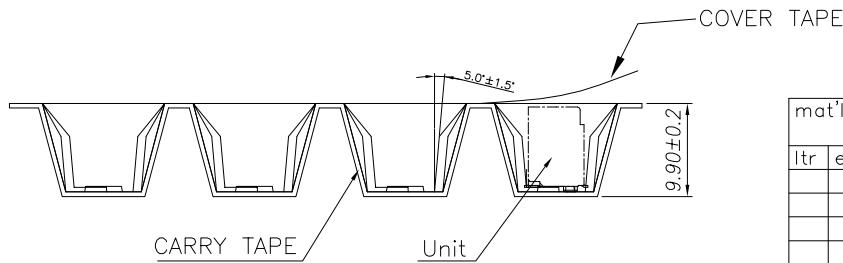
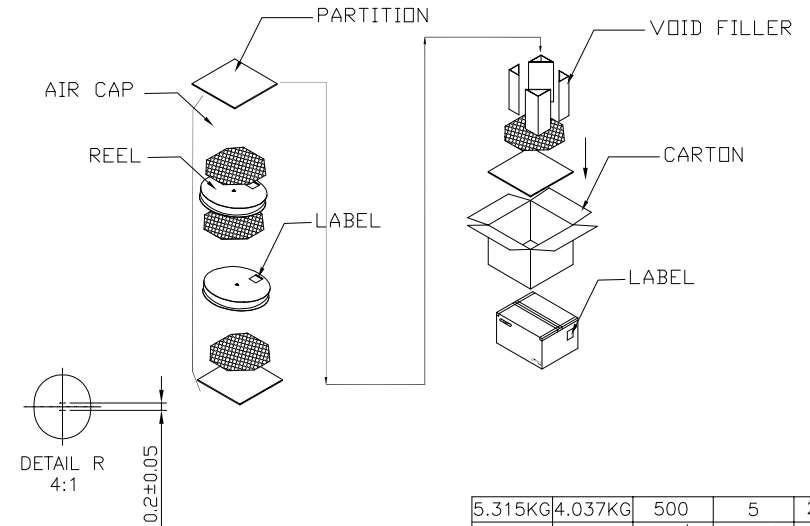
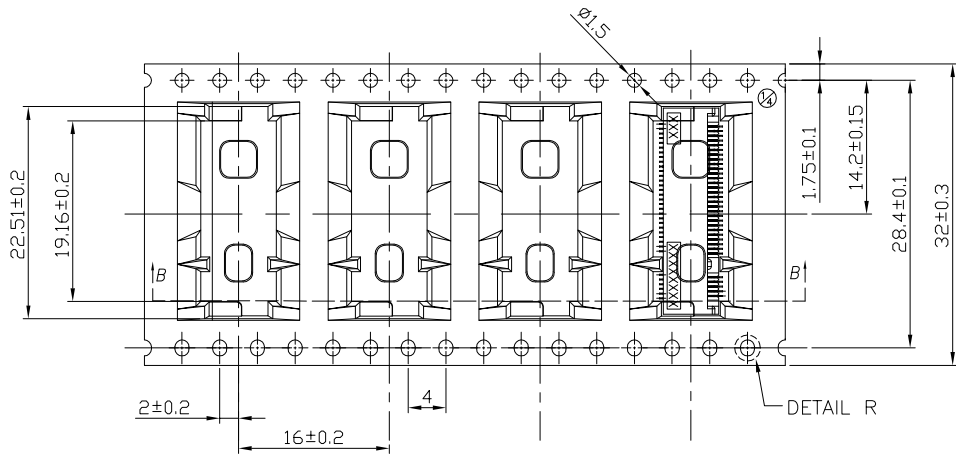

5.315KG	4.037KG	500	5	2500
GROSS WEIGHT	NET WEIGHT	PCS/ REEL	REEL/ CARTON	PCS/ CARTON

mat'l. code	surface	tolerance	projection	product family
-	-	ASME_Y14.5		-
ltr	ecn	no	dr	date
tolerances unless otherwise specified				title
	angles	lineal	MM	M.2_CONNECTOR
	±2'	.0±.0.30	←→	8.5H_STD_KEY_B
		.00±.0.25	scale N/A	
		.000±.0.10		
dr	BEER_FU	2013-05-02		dwg no
engr	BEER_FU	2013-05-02		sheet 3 of 3
chr	BEER_FU	2013-05-02		size
appd	PM_ZHENG	2013-05-02		A4
sheet index	revision sheet	c		type
		3		CUSTOMER Drawing