

CUSTOMER PRINT

PART NUMBER: SF8282-XPG-5XX

- NOTES:
 1. FINISHED ASSEMBLIES AND LOOSE PARTS BAGGED.
 2. LABEL WITH CONXALL PART NUMBER, DATE CODE AND P/N BARCODE PLACED ON BAG
 3. SEE DRAWING HPSFMISTD FOR HOLE PATTERNS
 4. FOR FIELD INSTALLATION, SEE INSTRUCTION SHEET 2 OF 2.
 5. ALL DIMENSIONS ARE REFERENCE EXCEPT THOSE WITH A TOLERANCE

CUSTOMER APPROVAL
 THIS DOCUMENT CONTAINS CONFIDENTIAL INFORMATION PROPRIETARY TO CONXALL CORPORATION. ANY REPRODUCTION, DISCLOSURE, OR USE OF THIS DOCUMENT / INFORMATION IS EXPRESSLY PROHIBITED UNLESS AUTHORIZED IN WRITING BY CONXALL CORPORATION.
 APPROVED BY: _____
 DATE: _____

ASSEMBLY P/ N	NO. OF CONTACT
SF8282-2PG-5XX	(2) # 20
SF8282-3PG-5XX	(3) # 20
SF8282-4PG-5XX	(4) # 20
SF8282-5PG-5XX	(5) # 20
SF8282-6PG-5XX	(6) # 20
SF8282-7PG-5XX	(7) # 20
SF8282-8PG-5XX	(8) # 20

520 = BACKSHELL WITH Ø.220 [5.6] GROMMET I.D.
 530 = BACKSHELL WITH Ø.330 [8.4] GROMMET I.D.

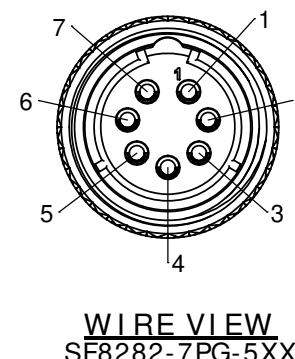
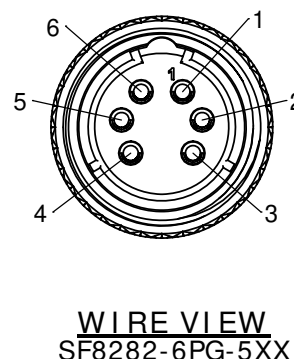
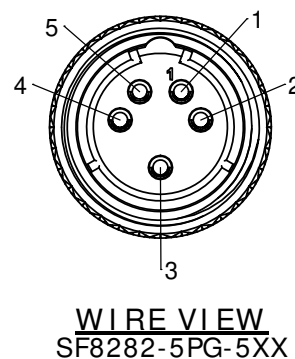
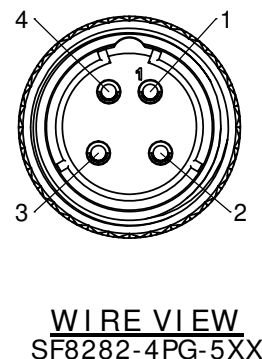
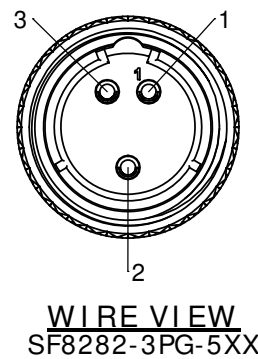
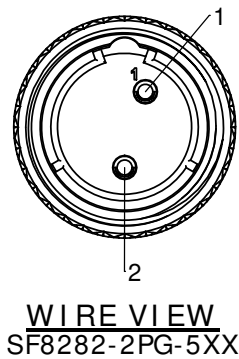
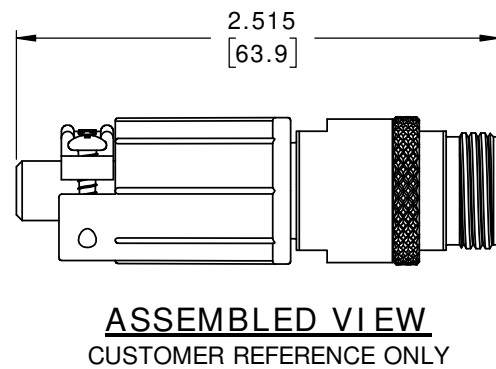
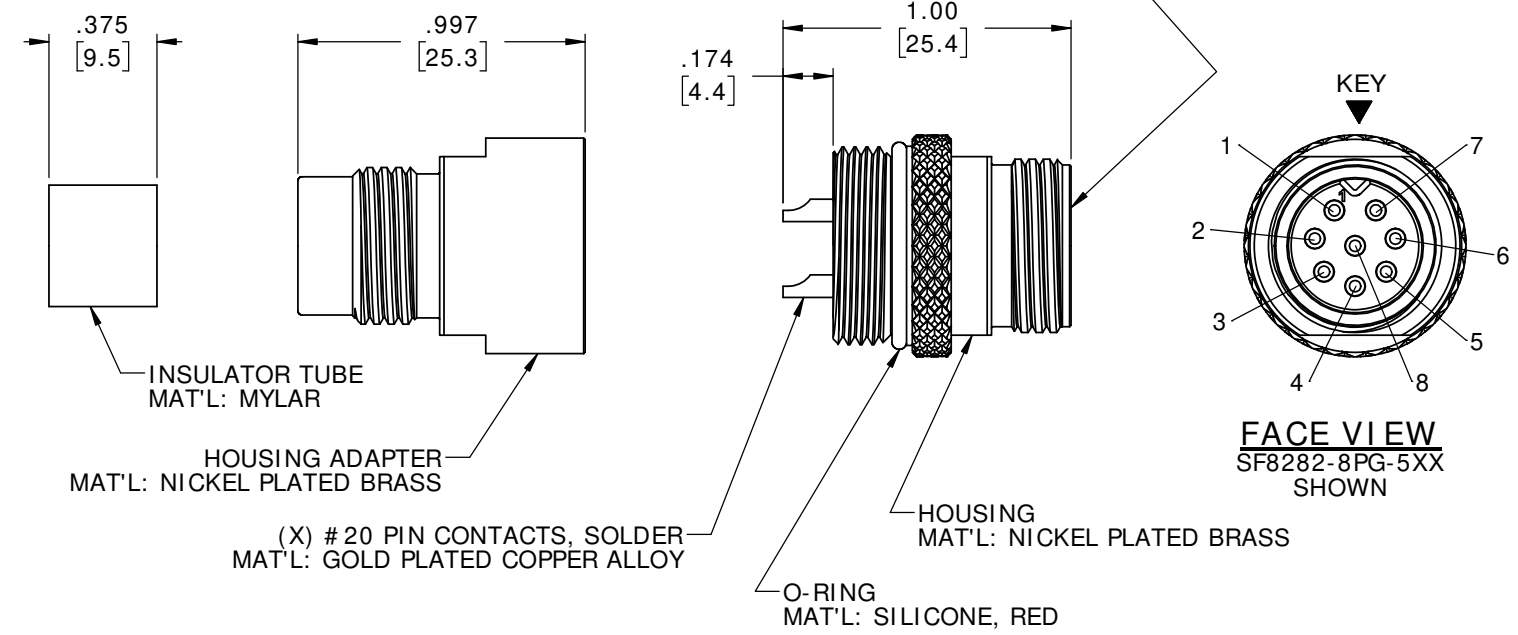
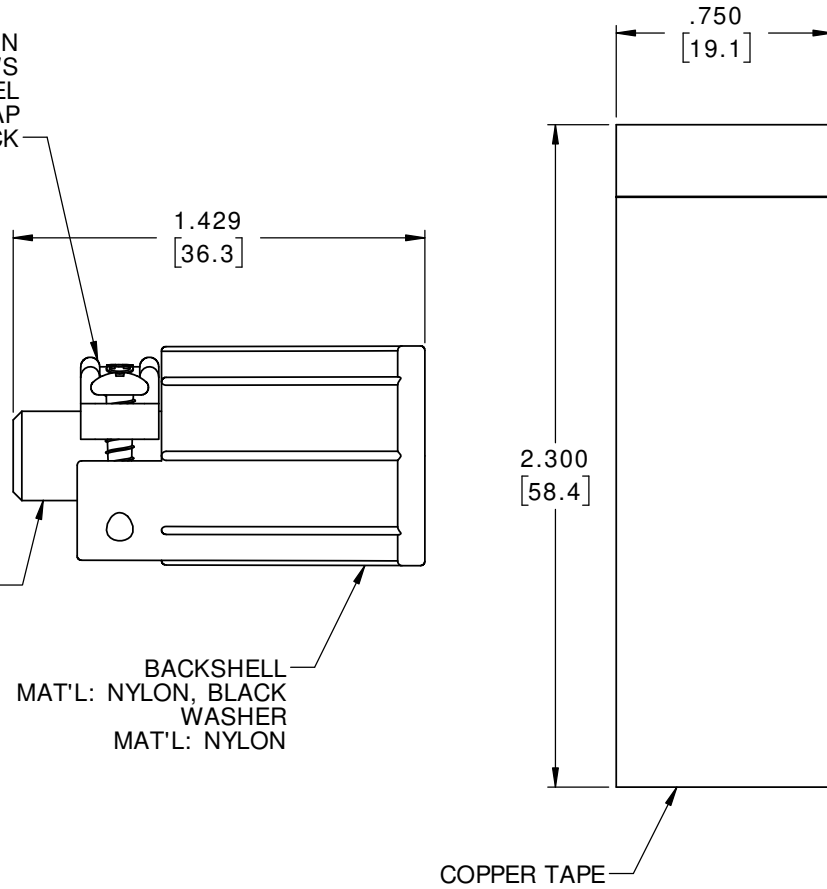
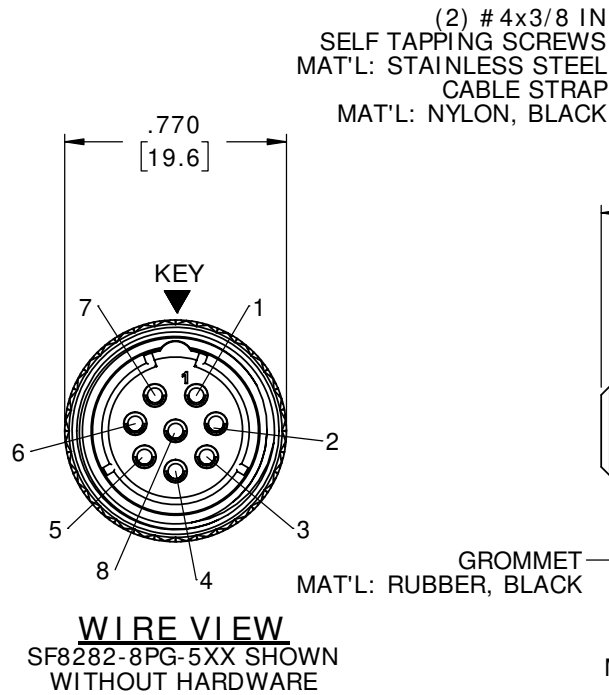

DIMENSIONS IN BRACKETS [] ARE IN MILLIMETERS

RoHS COMPLIANT

MA	01-28-19	RELEASED PER PDR 17011	
A	PNK	12-20-18 O-RING 4290S REPLACES SF6290S-1.	
	PNK	1-30-18 DRAWING CREATED PER PDR17011	
REV.	INIT.	DATE	DESCRIPTION
			ALL INFORMATION ILLUSTRATED IS THE PROPERTY OF CONXALL CORPORATION. UNAUTHORIZED DUPLICATION OR DISTRIBUTION OF THIS DOCUMENT IS PROHIBITED.
			UNLESS OTHERWISE SPECIFIED TOLERANCES 3 PLACE DECIMALS ±.005 ANGLES ±1° FRACTIONS ±1/16 - CRITICAL CHARACTERISTIC FLAG PER SPEC. XXXX
ORIG. DRAWN BY: PNK		DATE: 1-30-18	<p>601 E. WILDWOOD VILLA PARK, IL 60181</p>
CHECKED BY:			
APPROVED BY:			TITLE: CABLE-TO-CABLE ASSEMBLY (2-8) #20 PIN CONTACTS, SOLDER SHIELDED MINI-CON-X STANDARD PRODUCT
SCALE: NTS	SIZE: B	SHEET: 1 OF 2	CUSTOMER: SF8282-XPG-5XX
FILE: SF8282-XPG-5XX	DIRECTORY: SLW	PART NUMBER: SF8282-XPG-5XX	REV: A

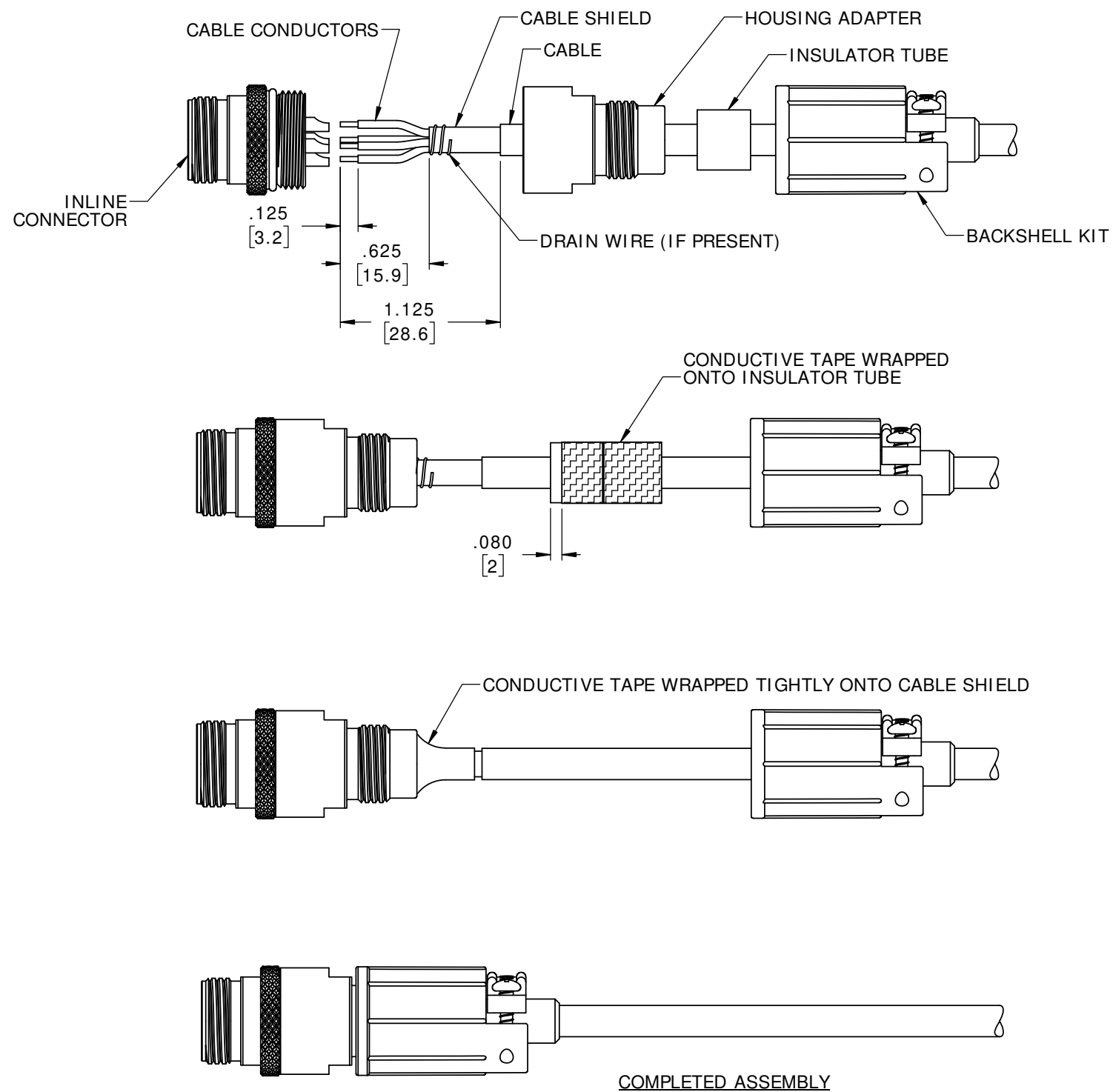

CABLE WIRING AND ASSEMBLY INSTRUCTIONS:

STEP 1. SLIDE HOUSING ADAPTER, INSULATOR TUBE, AND BACKSHELL KIT, ONTO CABLE IN THE ORDER SHOWN.

STEP 2. STRIP CABLE JACKET AND WIRES TO LENGTH. EXCESS CABLE SHIELD MUST BE TRIMMED OR WRAPPED AROUND WIRES. IF PRESENT, USE THE DRAIN WIRE TO WRAP THE CABLE SHIELD IN PLACE.

STEP 3. SOLDER WIRES TO CONTACTS.

STEP 4. THREAD HOUSING ADAPTER ONTO CONNECTOR AND TIGHTEN TO 5 LB-IN [0.56 N-m] MINIMUM TORQUE.

STEP 5. PEEL-OFF THE BACKING OF THE CONDUCTIVE TAPE AND WRAP IT AROUND THE INSULATOR AS SHOWN.

STEP 6. SLIDE INSULATOR/CONDUCTIVE TAPE INTO THE BACK OF THE CONNECTOR. FORM FREE END OF CONDUCTIVE TAPE TIGHTLY ONTO THE SHIELD OF THE CABLE.

STEP 7. SLIDE AND THREAD THE BACKSHELL KIT ONTO CONNECTOR. TIGHTEN TO 5 LB-IN [0.56 N-m] MINIMUM TORQUE.

STEP 8. TIGHTEN THE TWO BACKSHELL SCREWS TO SECURE THE CABLE IN THE BACKSHELL.

MA	04-03-19	RELEASED PER PDR 17011	
A	PNK	12-20-18	O-RING 4290S REPLACES SF6290S-1.
	PNK	1-30-18	DRAWING CREATED PER PDR 17011
REV.	INIT.	DATE	DESCRIPTION
ALL INFORMATION ILLUSTRATED IS THE PROPERTY OF CONXALL CORPORATION. UNAUTHORIZED DUPLICATION OR DISTRIBUTION OF THIS DOCUMENT IS PROHIBITED.		ORIG. DRAWN BY: PNK	DATE: 1-30-18
UNLESS OTHERWISE SPECIFIED TOLERANCES 3 PLACE DECIMALS ±.005 ANGLES ±1° FRACTIONS ±1/16		CHECKED BY:	 601 E. WILDWOOD VILLA PARK, IL 60181
△ - CRITICAL CHARACTERISTIC FLAG PER SPEC. XXXX		APPROVED BY:	
SCALE	SIZE	SHEET	TITLE:
NTS	B	2 OF 2	CABLE-TO-CABLE ASSEMBLY (2-8) #20 PIN CONTACTS, SOLDER SHIELDED MINI-CON-X STANDARD PRODUCT
FILE:	DIRECTORY:	PART NUMBER:	REV
FILE NAME	SLW	SF8282-XPG-5XX	A